

THERMOROSSI ^{tr}

LAMBDA S29 – S35 – S46 EVO5

ITA - MANUALE DI INSTALLAZIONE, USO E MANUTENZIONE.

FRA - MANUEL D'INSTALLATION, D'UTILISATION ET D'ENTRETIEN.

ENG - INSTALLATION, USE AND MAINTENANCE GUIDE.

DEU - INSTALLATIONS-, BETRIEBS- UND WARTUNGSANLEITUNG.

ESP - MANUAL DE INSTALACIÓN, USO Y MANTENIMIENTO.

NL - HANDLEIDING VOOR INSTALLATIE, GEBRUIK EN ONDERHOUD.



ITA - Informazioni importanti per la sicurezza ed il corretto funzionamento.

FRA - À lire impérativement ! Informations importantes pour la sécurité et le bon fonctionnement.

ENG - Must read! Important information for safety and correct operation.

DEU - Unbedingt lesen! Wichtige Informationen zur Sicherheit und zum sicheren Betrieb.

ESP - ¡Leer! Informaciones importantes para la seguridad y el correcto funcionamiento.

NL - Belangrijke informatie voor de veiligheid en correcte werking.

INDEX

1 – INTRODUCTION.....	4
2 – TECHNICAL CHARACTERISTICS.....	6
3 – GENERAL DESCRIPTION	7
4 – INSTALLATION.....	9
5 – MOUNTING THE MOTOR-OPERATED ANTICONDENSATION UNIT	23
6 – USE OF THE GENERATOR.....	26
7 – CLEANING AND MAINTENANCE	31
8 – ALARMS	34
9 – SMOKE DISCHARGE TUBE	35
10 – ROOM VENTILATION	37
11 – ELECTRICAL WIRING	38
12 – TROUBLESHOOTING CAUSE - SOLUTION	39
13 – CONDITIONS OF WARRANTY	40

EU Declaration of Conformity (DoC) / Dichiarazione di Conformità UE (DoC)

Company name: **THERMOROSSI S.P.A.** Postal address: **VIA GRUMOLO, N° 4**
 Azienda: **THERMOROSSI S.P.A.** Indirizzo: **VIA GRUMOLO, N° 4**
 Postcode and city: **36011 ARSIERO (VI)** Telephone number: **0445/741310**
 Codice postale e città: **36011 ARSIERO (VI)** Numero di telefono: **0445/741310**
 E-mail address: **INFO@THERMOROSSI.IT**
 Indirizzo e-mail: **INFO@THERMOROSSI.IT**

declare that the DoC is issued under our sole responsibility and belongs to the following product:
 dichiara che la dichiarazione viene rilasciata sotto la propria responsabilità e si riferisce al seguente prodotto:

Apparatus model / Product: **Wood logs boiler** Trademark: **THERMOROSSI S.P.A.**
 Descrizione prodotto: **Caldia a legna** Marchio: **THERMOROSSI S.P.A.**

Models: **LAMBDA S29 EVO5**
 Modelli: **LAMBDA S35 EVO5**
LAMBDA S46 EVO5

The object of the declaration described above is in conformity with the relevant Union harmonisation legislation:
 L'oggetto della dichiarazione di cui sopra è conforme alla pertinente normativa di armonizzazione dell'Unione:

- **Direttiva 2014/30/UE, EMCD**
- **Direttiva 2014/35/UE, LVD**
- **Direttiva 2011/65/UE, RoHS**
- **2014/30/EU Directive, EMCD**
- **2014/35/EU Directive, LVD**
- **2011/65/EU Directive, RoHS**

Sono state applicate le seguenti norme armonizzate e/o specifiche tecniche:
 The following harmonised standards and/or technical specifications have been applied:

EN 55014-1 EN 60335-1
 EN 55014-2 EN 60335-2-102 EN 50581
 EN 61000-3-2 EN 62233
 EN 61000-3-3

EN 303-5 tests carried out by the notified laboratory Kiwa Cermet Italia S.p.a (N.B. 0476) Viale Venezia, 45 31020 San Vendemiano (TV).

Arsiero, 10/04/2023

Firma/Sign.



IT – SCHEDE PRODOTTO (UE 2015/1187) EN – PRODUCT FICHE (EU 2015/1187) FR – FICHE PRODUIT (UE 2015/1187) NL – PRODUCTGEGEVENSBLAD (EU 2015/1187) DE – PRODUKTDATENBLATT (EU 2015/1187) ES – FICHA DE PRODUCTO (UE 2015/1187)	IT – MARCHIO EN – BRAND FR – MARQUE NL – MERK DE – MARKE ES – MARCA	THERMOROSSI S.P.A.		
IT – MODELLO EN – MODEL FR – MODÈLE NL – MODEL DE – MODELL ES – MODELO	LAMBDA S29 EVO5	LAMBDA S35 EVO5	LAMBDA S46 EVO5	
IT – CLASSE DI EFFICIENZA ENERGETICA EN – ENERGY EFFICIENCY CLASS FR – CLASSE D'EFFICACITÉ ÉNERGÉTIQUE NL – ENERGIE EFFICIENTIEKLASSE DE – ENERGIEEFFIZIENZKLASSE ES – CLASE DE EFICIENCIA ENERGÉTICA	A +	A +	A +	
IT – POTENZA TERMICA NOMINALE EN – RATED HEAT OUTPUT FR – PUISSANCE THERMIQUE NOMINALE NL – NOMINALE WARMTEAFGIFTE DE – NENNWÄRMELEISTUNG ES – POTENCIA CALORÍFICA NOMINAL	30 kW	31 kW	40 kW	
IT – INDICE DI EFFICIENZA ENERGETICA EN – ENERGY EFFICIENCY INDEX FR – INDICE D'EFFICACITÉ ÉNERGÉTIQUE NL – ENERGIE-EFFICIENTIE-INDEX DE – ENERGIEEFFIZIENZINDEX ES – ÍNDICE DE EFICIENCIA ENERGÉTICA	116	117	123	
IT – EFFICIENZA ENERGETICA STAGIONALE DI RISCALDAMENTO DI AMBIENTE EN – SEASONAL SPACE HEATING ENERGY EFFICIENCY FR – EFFICACITÉ ÉNERGÉTIQUE SAISONNIÈRE POUR LE CHAUFFAGE DES LOCAUX NL – SEIZOENSGEBONDEN ENERGIE-EFFICIENTIE VOOR RUIMTEVERWARMING DE – RAUMHEIZUNGS-JAHRESNUTZUNGSGRAD ES – EFICIENCIA ENERGÉTICA ESTACIONAL DE CALEFACCIÓN DE ESPACIOS	79%	80%	84%	
IT – RISPETTARE TUTTE LE ISTRUZIONI RIPORTATE SUL MANUALE DI INSTALLAZIONE USO E MANUTENZIONE EN – ALWAYS FOLLOW THE INSTRUCTIONS PROVIDED IN THE OPERATING AND MAINTENANCE MANUAL FR – RESPECTER TOUTES LES INSTRUCTIONS CITÉES DANS LA NOTICE D'INSTALLATION, UTILISATION ET ENTRETIEN NL – VOLG ALTIJD DE INSTRUCTIES VAN DE INSTALLATIE-, GERUIKERSHANDLEIDING EN DE ONDERHOUDSVOORSCHRIFTEN DE – ERFÜLLEN DIE ANWEISUNGEN DER INSTALLATION, NUTZUNG UND WARTUNG, DIE IN DEM ANLEITUNGSBUCH SIND ES – RESPECTAR LAS INSTRUCCIONES REPORTADAS EN EL MANUAL DE UTILIZACIÓN Y MANTENIMIENTO				

1 – INTRODUCTION

1.1 SAFETY GUIDELINES

This installation, use and maintenance manual is an integral and essential part of the product and must be kept by the user. Before commencing with the installation, use and maintenance of the product, carefully read this guide. All local, national and European regulations regarding the installation and use of the appliance must be met. The Manufacturer recommends carrying out all the maintenance operations described in this manual.

This appliance must only be used as intended by the manufacturer. Any other use is considered incorrect and therefore hazardous; consequently, the user shall be totally liable for the product if used improperly. Installation, maintenance and repairs must be carried out by professionally qualified personnel, certified according to Decree no. 37 of 22 January 2008 and in compliance with current regulations. In case of repairs only original spare parts supplied by the manufacturer must be used. Incorrect installation or poor maintenance can injure or damage people, animals or things; in this case the manufacturer shall be relieved of all responsibility.

Before beginning any cleaning or maintenance operation switch off the appliance by means of the 0/I main switch and disconnect the plug from the electrical power socket. The product must be installed in locations suitable for fire-fighting and furnished with all the services (power and outlets) which the appliance requires for a correct and safe operation. Any repairs or actions carried out on any systems, components or internal parts of the appliance, or on any of the accessories supplied with it, that are not specifically authorised by Thermorossi S.p.A, will automatically void the warranty and the manufacturer's responsibility, pursuant to Italian Decree no. 224 of the President of the Republic of 24/05/1988, art. 6/b.

It is recommended to keep this manual in a safe place that is easily accessible to all users; if the manual is lost or deteriorated contact the manufacturer for a replacement copy. If the appliance is sold or transferred to another user ensure that the manual is handed over with it. The images and figures featured in this manual are purely illustrative and may differ from the actual product. Furthermore, Thermorossi reserves the right to apply changes to the content of this manual anytime and without notice.

Thermorossi S.p.A. retains copyright on this manual. These instructions may not be reproduced or communicated to third parties or used in any other way without the necessary authorisation.

1.2 SAFETY STANDARDS



PERSONAL INJURY

This safety symbol identifies important messages throughout the manual. Read the information marked by this symbol carefully as non-observance of this message can cause serious injury to persons using the appliance.



DAMAGE TO PROPERTY

This safety symbol identifies messages or instructions that are fundamental for the generator to function well. To avoid serious damage to the appliance, adhere strictly to these instructions.



INFORMATION

This symbol indicates important instructions for good functioning of the generator. If this information is not correctly observed, the performance of the appliance will not be satisfactory.

1.3 RECOMMENDATIONS



ATTENTION: it is mandatory for the appliance to be inspected by an **Authorised Technical Service Centre** within 30 days from its installation. Once this time has elapsed the manufacturer's warranty will be immediately voided, as specified in the warranty certificate.

Before using the appliance, carefully read every section of this installation, use and maintenance guide as knowledge of the information and the regulations contained in it are essential for a correct use of the appliance.



The entire operation concerning the connection of the electric panel must be carried out by expert personnel; no responsibility will be accepted for damages, even to third parties, if the instructions for installation, use and maintenance of the appliance are not followed scrupulously. Modifications made to the appliance by the user or on his behalf, must be considered to be under his complete responsibility. The user is responsible for all the operations required for the maintenance of the appliance before and during its use.

1.4 GENERAL GUIDELINES



Attention: the appliance must be connected to a system provided with a PE conductor (in compliance with the specifications concerning low-voltage equipment). Before installing the appliance check the efficiency of the earth circuit of the power supply system.

Attention: the power supply line must have a section which is suitable for the power of the equipment. The cable section must in any case be no less than 1.5 mm². The appliance requires powering with a voltage of 230V and 50 Hz. Voltage variations greater than 10% of the nominal value can cause irregular operation or damage the electrical device. Position the appliance so that the electric power outlet in the room is easily accessible. Ensure that a suitable differential switch is installed upstream from the equipment. Position the power supply cable in order to prevent any contact of the latter with the smoke exhaust pipe or hot parts of the appliance. If the power cord is damaged it must be replaced by the manufacturer or by an authorised technical assistance service in order to avoid risks.

The product must not be used by children under the age of 8 years, by persons with physical, mental or sensorial impairments, or by persons who are not familiar with the instructions for use and maintenance of the product (the instructions are found in this booklet). Children must not play with the appliance.

ATTENTION: before every use make sure that the burner and the ash pan are clean, and check that the firebox door is firmly closed and air tight.

ATTENTION: the door must always remain shut tight when the appliance is operating. It is strictly forbidden to open the door while the flame is still burning. During operation, the smoke exhaust pipes, door, handles and some parts of the appliance may reach extremely high temperatures: be careful not to touch them and also educate children to be aware of said risks. Do not expose your body to hot air for long, do not overheat the room in which the appliance is installed, as these actions could cause health problems. Do not expose plants or animals directly to the hot air flow as this could have noxious effects on them. It is prohibited to use any liquids or gases such as alcohol, petrol, etc. to light or rekindle the fire, use only thin wood. Do not place non-heat resistant or inflammable or combustible objects in the vicinity of the appliance: keep them at a suitable distance. Do not place wet clothing to dry on the appliance. When using a clothes horse, keep at a suitable distance. It is strictly prohibited to disconnect the appliance from the electrical power mains while it is in operation.



Caution: do not wet the appliance and do not touch the electrical parts with wet hands. Never vacuum hot ash: this could damage the vacuum device. All the cleaning operations described in this manual must be carried out when the appliance is cold and shut off.



Attention! Warning for Swiss users

Refer to the local cantonal regulations imposed by the Fire Department (Mandatory signalling and safety distances) and the Note concerning installation of heaters issued by the Association of Cantonal Fire Agencies (VKF - AEAI).



ATTENTION: it is mandatory to earth the appliance. If this instruction is not observed serious damage, which is not covered by warranty, will result to the body of the appliance. Have an electrician check the earthing. There must be no electric potential (Volt) between the earth of the generator and the actual earth of the system.

1.5 TRANSPORTATION AND STORAGE

TRANSPORTATION AND HANDLING

The appliance body must always be in a vertical position when handled and exclusively by means of trolleys. Take special care to protect the electric panel and all the fragile parts from mechanical impact which could damage them and their correct functioning. We recommend handling the generator with the casing removed so as to avoid any damage.

STORAGE

The appliance must be stored in a humid-free environment and sheltered from the weather; avoid placing the appliance directly on the ground. The Company denies all responsibility for damage caused to wood floors or floors made from any other material. It is inadvisable to store the product for long periods of time.

1.6 GUIDELINES FOR CORRECT DISPOSAL OF THE PRODUCT



At the end of the product's useful life it must be disposed of in compliance with applicable regulations and in respect of the environment, not with urban waste. The product must be consigned to designated sorted waste collection centres for the disposal of electronic waste authorised by the local municipal councils. Correct disposal not only helps safeguard the environment but it also promotes recovery and recycling of the materials.

2 – TECHNICAL CHARACTERISTICS

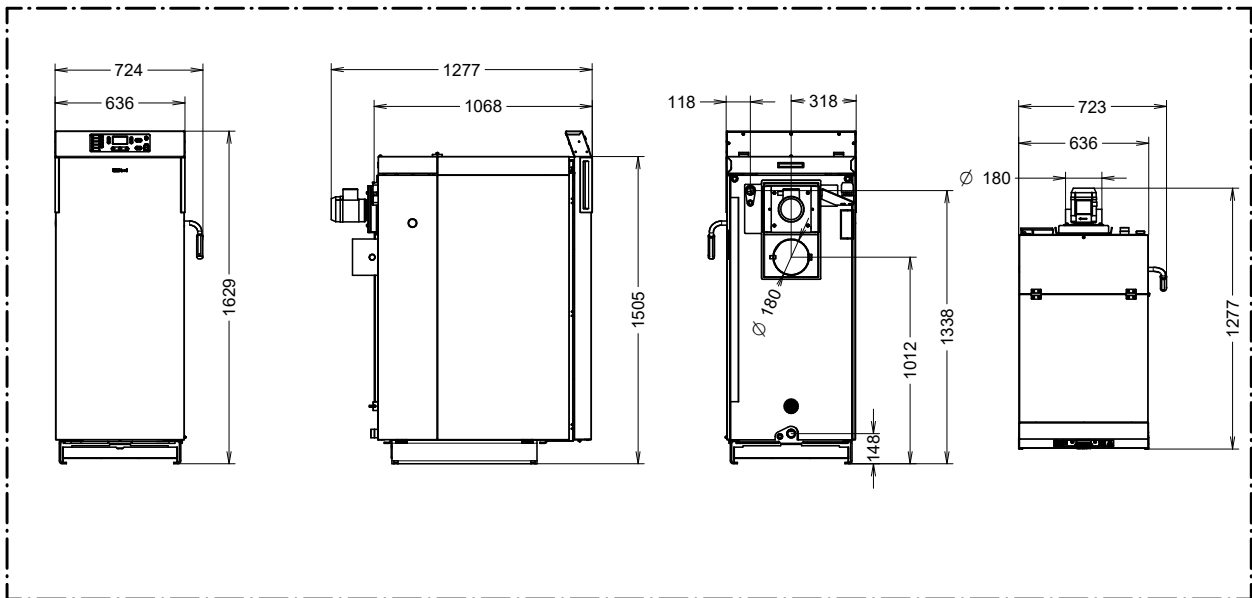

The spiral tube scraper lever can be installed both on the right-hand and left-hand sides of the generator.

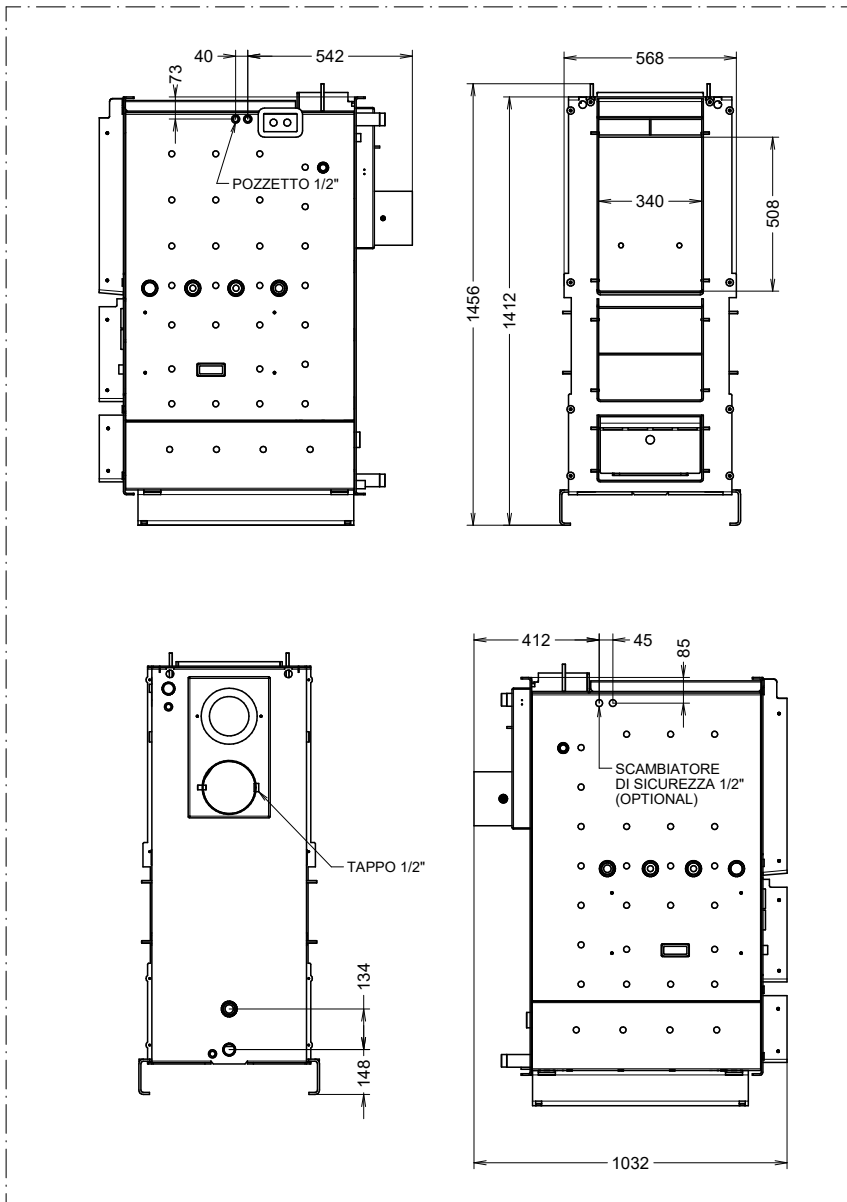

Legenda	Key
Pozzetto 1/2"	Pocket 1/2"
Tappo 1/2"	Plug 1/2"
Scambiatore sicurezza 1/2" (optional)	Safety heat exchanger 1/2" (optional)

	M.U.	LAMBDA S29 EVO5	LAMBDA S35 EVO5	LAMBDA S46 EVO5
Height	mm	1.629	1.629	1.629
Depth	mm	1.277	1.277	1.277
Width	mm	724	724	724
Empty weight	Kg	600	600	605
Firebox power *	kW	33.4	34.9	45.3
Output to water *	kW	29.6	30.9	39.9
Appliance class		5	5	5
Consumption *	Kg/h	7.89	8.16	10.06
Operating autonomy *	h	3.2	3.2	3.1
Max log length	mm	500	500	500
Ø smoke exhaust pipe	mm	180	180	180
Max delivery water temperature	°C	80	80	80
Min water return temperature	°C	55	55	55
Draft	Pa / mbar	12 / 0.12	12 / 0.12	12 / 0.12
Average smoke temperature *	°C	117	122	152
Maximum smoke temperature *	°C	250	250	250
Smoke flow rate *	kg/s	0.017	0.018	0.023
Dimensions of the combustion chamber (LxHxP)	mm	401x695x547	401x695x547	401x695x547
Water content	Litres	122	122	122
Maximum operating pressure	bar	2.5	2.5	2.5
Maximum working pressure	bar	1.5	1.5	1.5
Min puffer tank capacity ****	Litres	1,500	1,500	1,500
Efficiency *	%	88.6	88.5	88.1
CO concentration with 10% O ₂ *	mg/m ³	40	38	26
Power supply voltage and frequency	V / Hz	230 / 50	230 / 50	230 / 50
Max electrical consumption	W	88	88	88
Electrical consumption in standby	W	6.5	6.5	6.5
Loss of load - water side at 10K	mbar	63.6	63.6	63.6
Loss of load - water side at 20K	mbar	15.9	15.9	15.9
Heatable volume **	m ³	790	830	1,050
Noise level ***	dB	55	55	55

* All the figures were recorded using 450 mm long logs, with a thermal value below 15,247 kJ/kg and a moisture content of 10.6%

** Important: It is important to take into consideration the fact that the heatable volume is greatly influenced by the insulation of the house (energy class of the building) and by the position of the appliance in the planimetry of the house, therefore the indicated values may vary, even significantly.

*** Test carried out with sound level meter at a distance of 3m.

**** The sizing of the puffer tank must be calculated by a qualified professional according to applicable regulations.

3 – GENERAL DESCRIPTION

3.1 OPERATING TECHNOLOGY

Your generator has been built to fully satisfy all your heating and practical requirements. Top-grade components and functions managed with microprocessor technology guarantee high reliability and optimal performance.

LAMBDA EVO5 uses reverse flame technology. The flame is drawn to the lower part of the boiler through the action of a suction device. The flame develops in the cast iron burner and the particular shape of the flame determines low emissions and an optimal smooth running.

3.2 WOOD FUEL

The only fuel permissible for use in this appliance is wood logs having a maximum length of 500 mm and moisture content below 20%.

Pay special attention to the characteristics of the wood: like all biomass generators good performance of the generator depends on the type of wood used and on its degree of seasoning.

Wood after one year of drying: still contains 40% moisture and generates an average 2000/2200 Kcal per Kg.

Wood after two years of drying: still contains an average of 25% moisture and generates approx. 3000 Kcal per Kg.

Wood after three years of drying: still contains an average of 15% moisture and generates approx. 3500 Kcal per Kg.

Store firewood correctly, preferably raised from the ground and protected from sources of moisture or humidity and the weather.

Excellent quality: ash, beech, maple, hornbeam, oak. Average quality: birch, alder and acacia.

Satisfactory quality: lime, poplar, willow, chestnut (only with a minimum seasoning of two years to reduce the tannin content), fir, larch. Other types of resinous woods are not suitable.

The wood should be cut as close as possible to the length of the combustion chamber in such a way as to completely cover the burner base and also to obtain a heavier load for a longer duration.

The logs must be placed parallel, next to each other, in order to leave the fewer gaps possible. To achieve the rated power the fuel load must sit on a bed of embers that does not exceed a thickness of 5 cm. Using larger logs could reduce the generator power. The maximum thermal value is achieved by using fuel having a diameter of 5/7 cm.



Use of fuel other than all-wood logs is forbidden. The use of fuel other than all-wood logs immediately voids the appliance warranty. Do not use the appliance as an incinerator, at the risk of voiding the warranty.

3.3 MAIN COMPONENTS

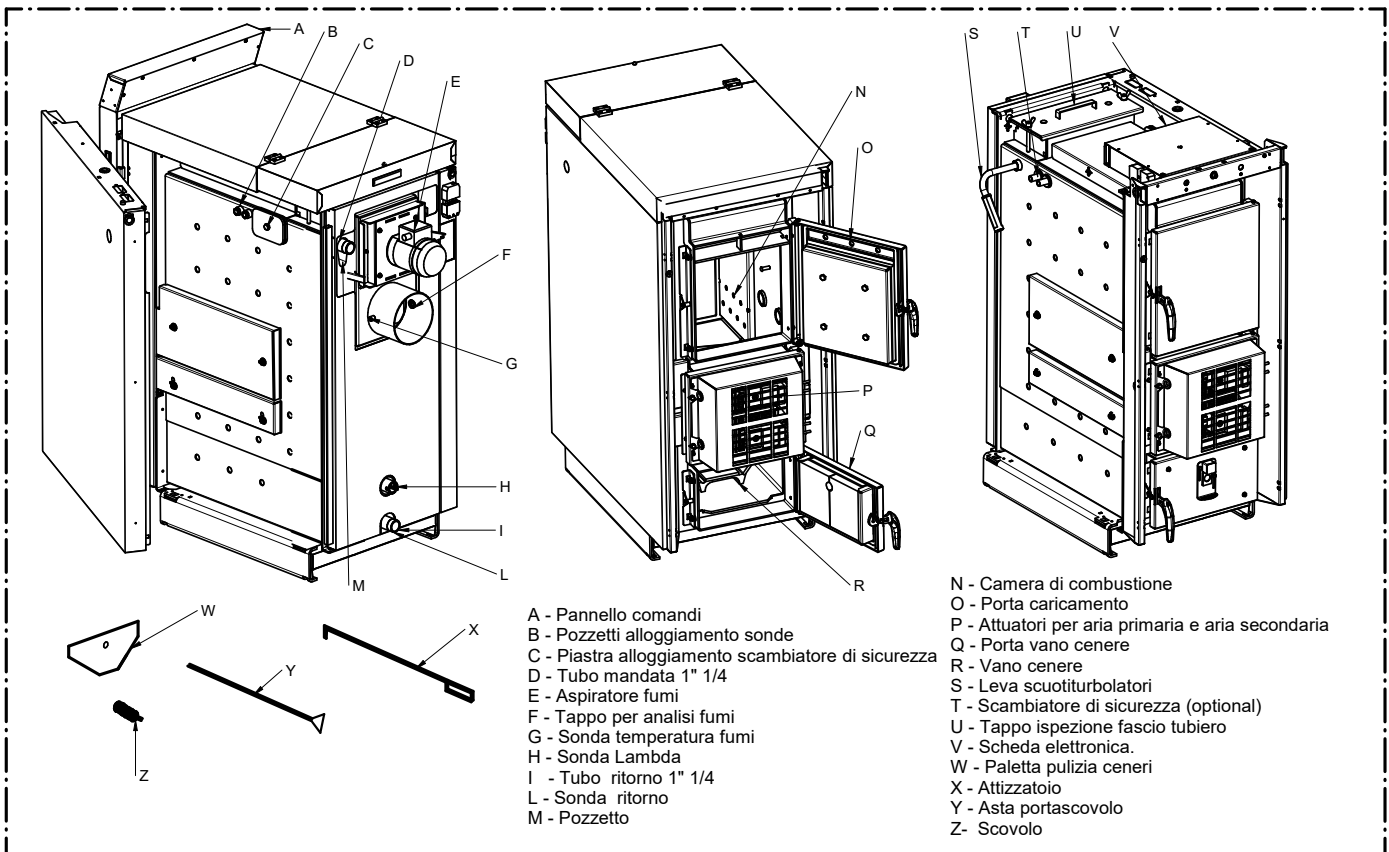

A	Control panel	O	Feed door
B	Sensor pockets	P	Actuators for primary and secondary air
C	Safety heat exchanger fixing plate	Q	Ash pan door
D	Delivery tube 1" ¼	R	Ash pan
E	Smoke suction unit	S	Spiral tube scraper lever
F	Smoke analysis cover	T	Safety heat exchanger (optional)
G	Smoke temperature sensor	U	Tube bundle inspection cover
H	Lambda sensor	V	Electronic board
I	Return tube 1" ¼	W	Ash cleaning tool
L	Return sensor	X	Riddling tool
M	Pocket	Y	Brush holder

N	Combustion chamber	Z	Cleaning brush
---	--------------------	---	----------------

4 – INSTALLATION

4.1 APPLIANCE LOCATION



Follow the general guidelines set out in paragraph 1.1 to the letter. Keep in mind that the flooring of the room in which the appliance is to be installed must withstand the combined weight of the appliance, the fuel, and the water contained in the appliance.

ATTENTION: the room where the appliance is installed must be well-ventilated and free from humidity and salty air. A high level of humidity or saltiness in the room can lead to the onset of rust or corrosion which will not be covered by warranty.

If inflammable materials are located in the vicinity of the appliance (e.g.: match-boarding, furniture, curtains, pictures and paintings, sofas) it is mandatory to comply with the minimum distances illustrated (see figure at right)

Installation in the vicinity of heat-sensitive materials is only permitted if suitable insulating and fireproof protection is placed between the object and the appliance (ref. Uni 10683). If the flooring is made of wood or any other combustible material, it is mandatory to install a fireproof floor protector plate between the appliance and the floor. Installation in the vicinity of heat-sensitive materials is only permitted if suitable insulating and fireproof protection is placed between the object and the appliance (ref. Uni 10683). Failure to observe this instruction will immediately invalidate the warranty.

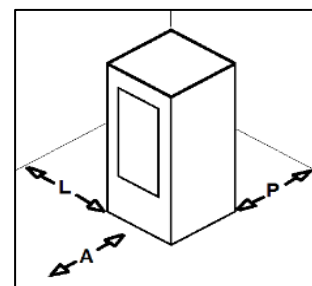

A = 200 mm
L = 200 mm
P = 200 mm



The installer must issue a certificate of conformity for the installation which includes the design plans and the following documents:

- a) Report containing the type of materials utilised.
- b) Project as defined in Article 5 of Ministerial Decree n° 37 22 January 2008.
- d) References to existing partial or previous declarations of conformity (e.g. electrical wiring).
- e) Copy of the certificate of recognition of the professional technical qualifications.



These documents must, by law, be kept together with the use and maintenance booklet. The customer is responsible for verifying, directly or indirectly, that the installation has been carried out to perfection in accordance with relevant regulations in force. Do not install the appliance in unsuitable rooms such as bedrooms, bathrooms, garages and/or lock-ups. It is forbidden to place the appliance in environments with an explosive atmosphere.



ATTENTION, the appliance is not simply a household appliance: if the instructions set out in this booklet are not followed and/or if installation of the appliance is not executed perfectly and/or the provisions in force are not strictly complied with, dangerous conditions could arise for both objects and persons. It is the user's responsibility to verify the presence, in the room, of a vent necessary for supplying oxygen to the generator.



The installer must provide the final user with verbal instructions on the correct use of the appliance when the appliance is set at work for the first time.

Legenda	Key
ISOLANTE TERMICO	HEAT INSULATING MATERIAL
100-200-800 Minimo	100-200-800 Minimum

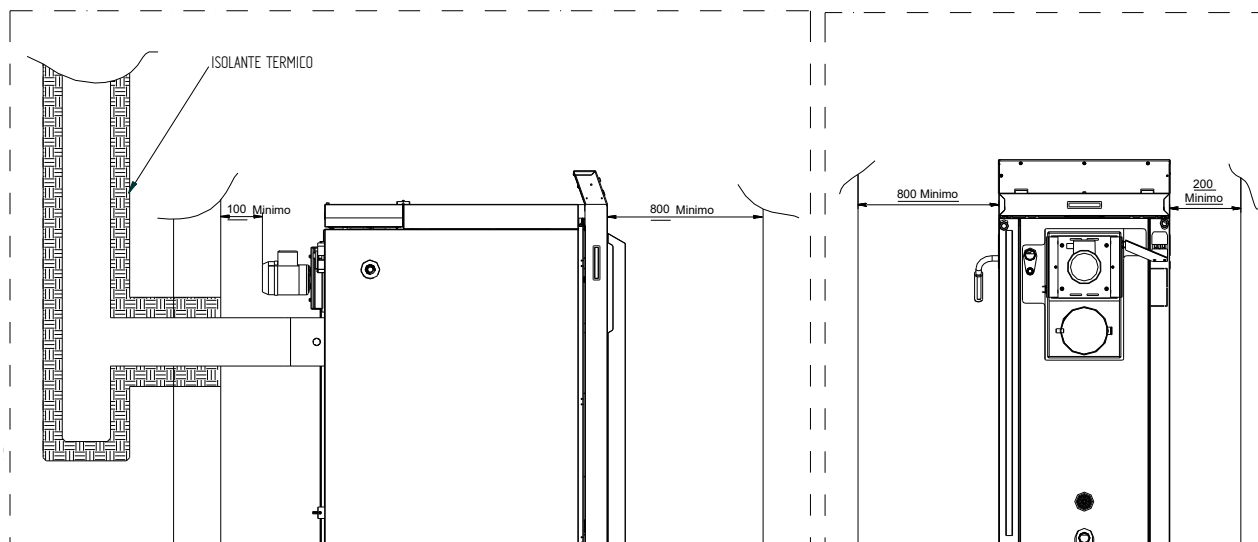

4.2 INSTALLATION OF THE SAFETY HEAT EXCHANGER (OPTIONAL)

The safety heat exchanger is mandatory in closed expansion tank systems. Installation of the safety heat exchanger requires removal of part of the casing. Follow the instructions below to perform this operation. By installing the approved thermal relief valve the safety heat exchanger absorbs the excess heat in the boiler, due to external causes, as soon as it rises to excessively high temperatures. This function is called fast disconnection phase.



IF THE SAFETY HEAT EXCHANGER IS INSTALLED TO PRODUCE DOMESTIC HOT WATER THE GUARANTEE FOR THE GENERATOR IS IMMEDIATELY VOIDED. INSTALLATION OF THE SAFETY HEAT EXCHANGER MUST BE CARRIED OUT BY A QUALIFIED PROFESSIONAL AND IN COMPLIANCE WITH APPLICABLE REGULATIONS. THE MAXIMUM PRESSURE OF THE HEAT EXCHANGER IS 6 bar AND THE INFLOWING WATER TEMPERATURE MUST NOT EXCEED 20°C.

1) Pull upwards to remove the top:

Legenda	Key
Dado ad alette M10	Wing nut M10
Rondella D10	Washer D10
Ribattino 8x35	Rivet 8x35
Porta ispezione completa	Complete inspection door
Leva azionamento turbolatori completa	Complete spiral tube scraper lever

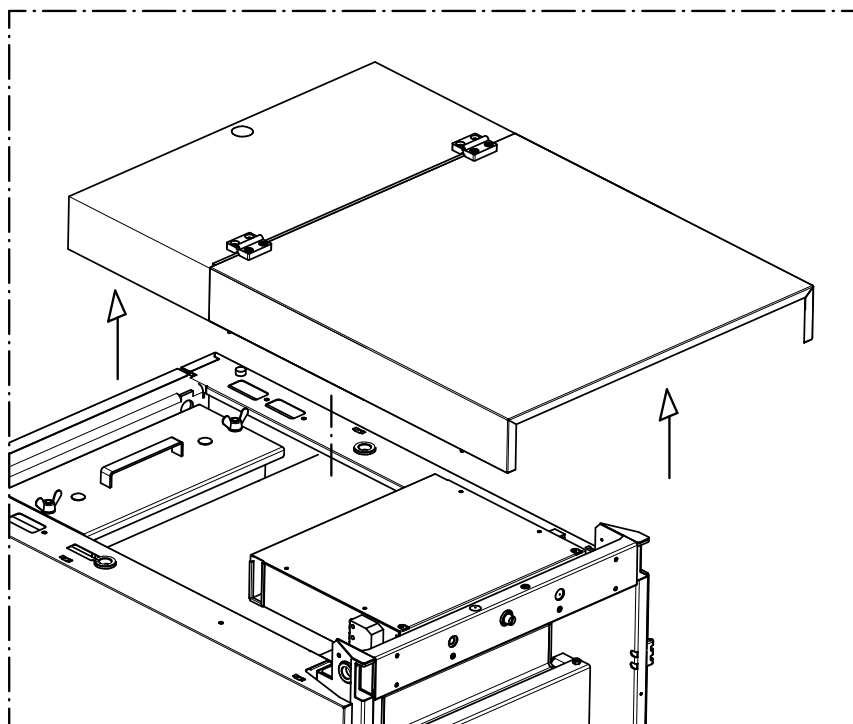

2) Undo the two M10 wing nuts on the complete inspection door and remove it by pulling upwards. Next, remove the rivet 8X35 and remove the whole spiral tube scraper lever by pulling it outwards:

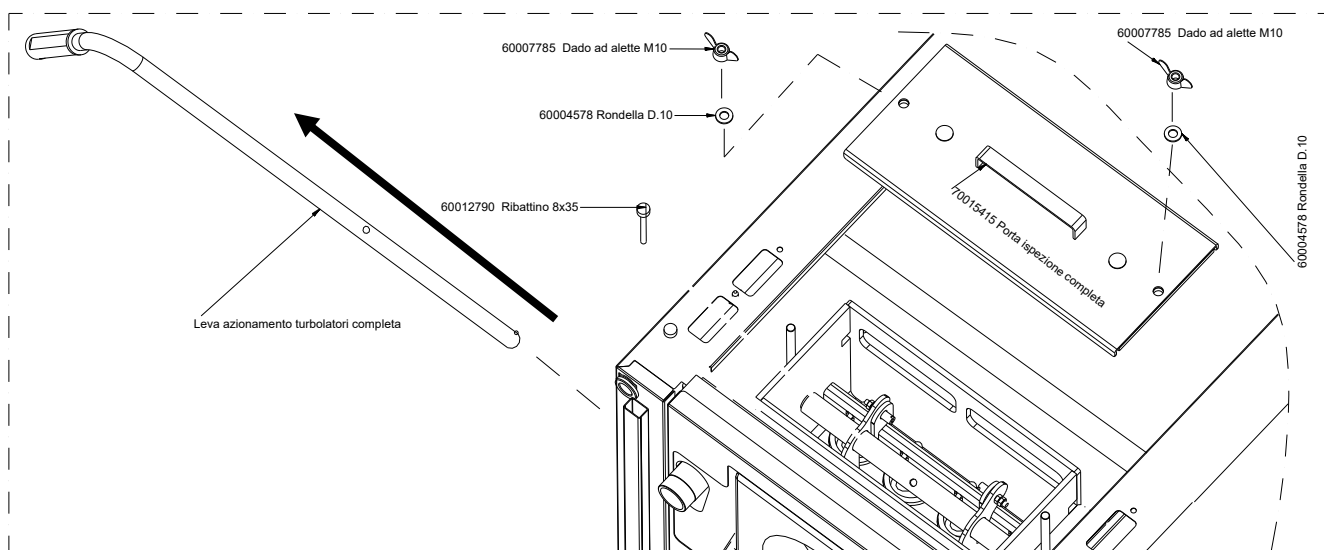

- 3) Now remove the sides of the casing by pulling up the two upper tabs:
N.B. take utmost care during this process not to pull the electric wires that are located inside it.



Legenda	Key
Vite TE 8x25 - 8x45	Hex head screw 8x25 / 8x45
Rondella 8x40	Washer 8x40
Rondella EPDM	Washer EPDM
Piatto chiusura serpentino	Coil fastening plate
Guarnizione nylon 8.1x4.8	Nylon gasket 8.1x4.8
KIT COMPLETO FORI SERPENTINO	COMPLETE COIL HOLE KIT

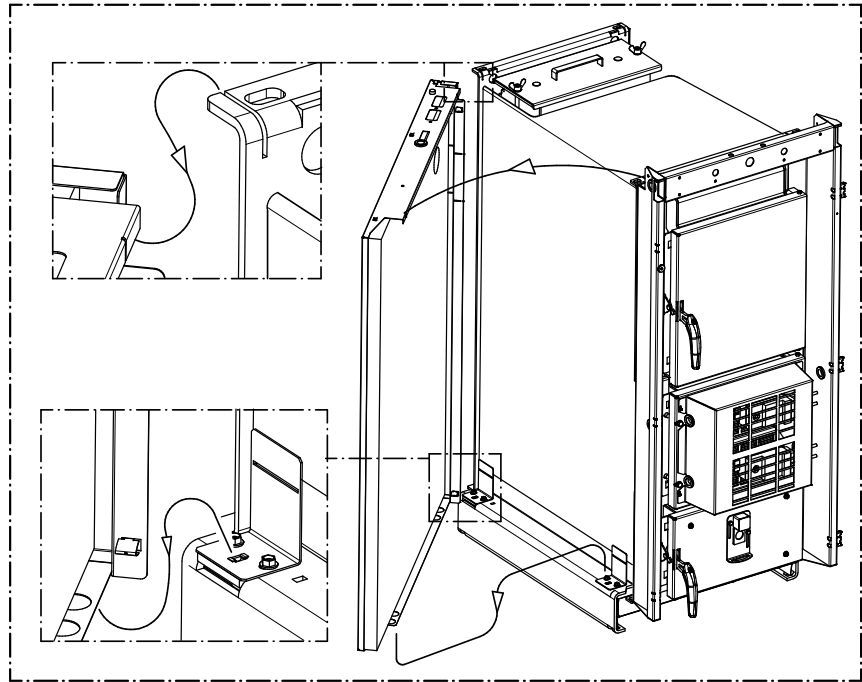

- 4) Undo screw 60005227 completely and screw 60007780 **only partially**
Attention: Only partially undo screw 60007780 to prevent the coil fastening plate from falling inside the body of the appliance!
 Completely remove the COMPLETE COIL HOLE KIT as illustrated in the figure below.

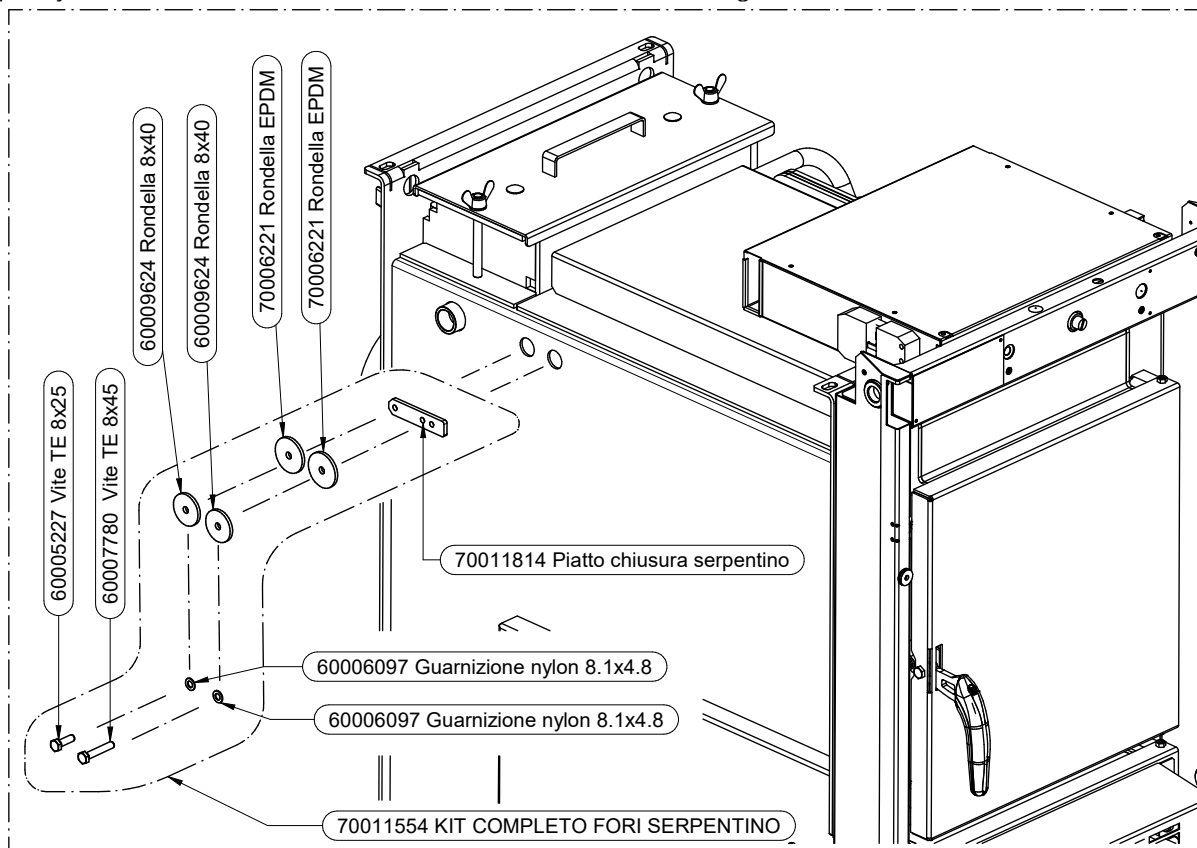

Installation, use and maintenance guide
LAMBDA S29 – S35 – S46 EVO5

- 5) Partially undo screw 60006245, it must not be unscrewed to the end of its thread.
Attention: Partially undo screw 60006245 to prevent the flange fastening crosspiece from falling inside the body of the appliance!
 Remove the COMPLETE HEAT EXCHANGER HOLE KIT as illustrated in the figure below:

Legenda	Key
Tappo scambiatore	Heat exchanger cover
Guarnizione serpentino	Coil gasket
Traversino fissaggio flangia	Flange fastening crosspiece
Vite TE 12X70	Hex head screw TE 12x70
Rondella 1/4" con inserto gomma	1/4" washer with rubber insert
KIT COMPLETO FORO SCAMBIATORE	COMPLETE HEAT EXCHANGER HOLE KIT

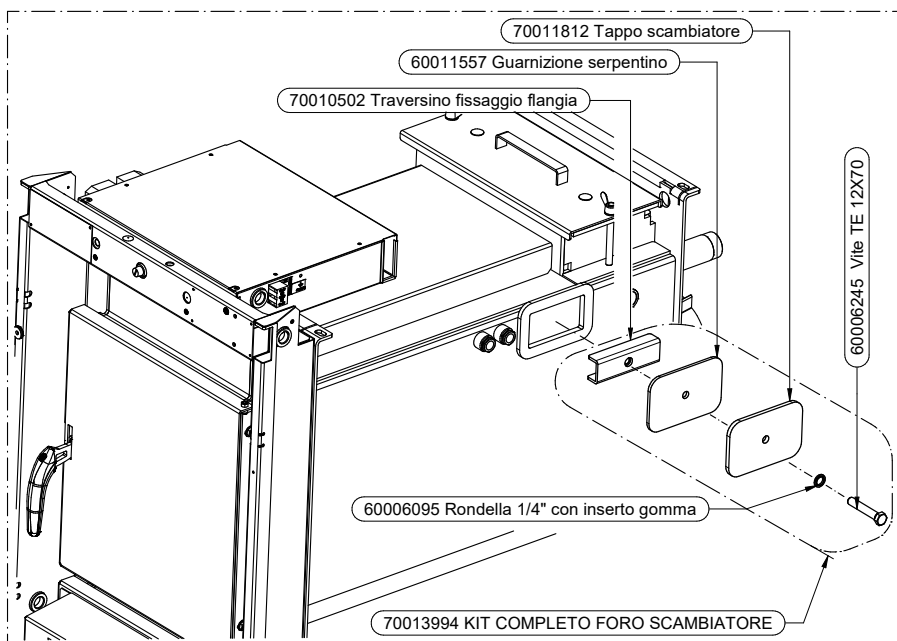

- 6) Insert the safety heat exchanger inside the appliance as illustrated in the following figure. Then remount the COMPLETE HEAT EXCHANGER HOLE KIT and tighten screw 60006245 all the way.

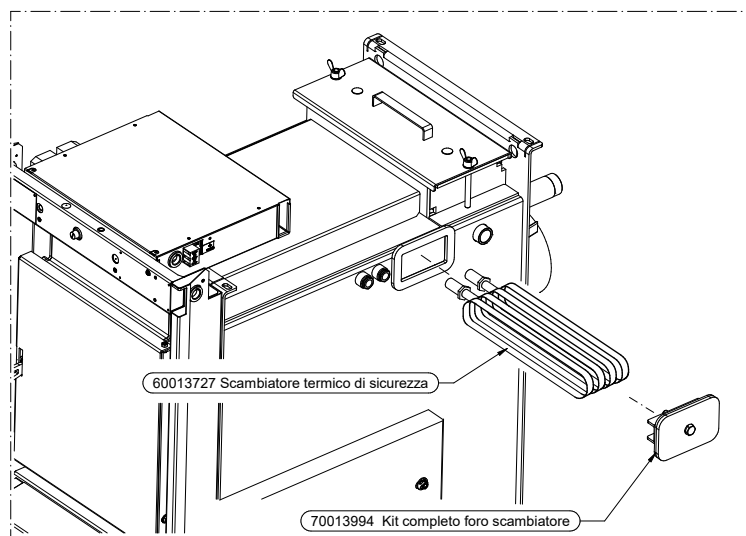

Legenda	Key
Scambiatore termico di sicurezza	Safety heat exchanger
Kit completo foro scambiatore	Complete heat exchanger hole kit

7) Fasten the two inlets with the Kit supplied with the heat exchanger and following the order indicated in the figure below:

Legenda	Key
Scambiatore termico di sicurezza	Safety heat exchanger
Dado 1/2"	Nut 1/2"
Rondella ottone	Brass washer
Guarnizione "OR"	O-Ring gasket

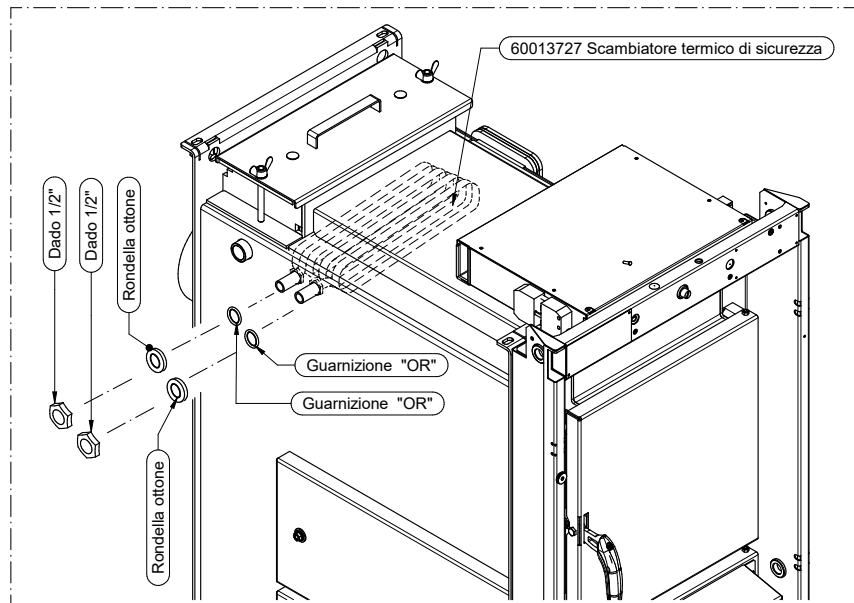

8) Install the certified and calibrated two-way thermal relief valve at the exchanger inlet, following the instructions provided by the manufacturer and install a discharge pipe.

The thermal relief valve must have the following characteristics:

- Double safety sensor for solid fuel generators
- Max working pressure: 10 bar
- Temperature range: 5÷110°C
- Calibration temperature 98°C
- Discharge capacity with $\Delta p = 1$ bar and $T=110^\circ\text{C}$: 3000 l/h
- Capillary tube length: 130 mm
- **Certified to standard EN 14597**

Lastly insert the sensitive element of the thermal relief valve by removing the pocket (M) and screwing in the pocket supplied with the valve.

ATTENTION: before reassembling the remaining parts make sure that the gaskets are tight by bringing the system to pressure.

9) Reassemble the parts by carrying out the above procedure in reverse order.



ATTENTION: A CONNECTION MUST BE MADE BETWEEN THE SAFETY VALVE AND THE OUTLET TO PREVENT DAMAGING MATERIALS SURROUNDING THE BOILER WHEN THE VALVE IS ACTIVATED. IT IS MANDATORY TO INSTALL A T UNION WITH TAP FOR DISCHARGING FROM THE BOILER.

4.3 RELOCATION OF THE SPIRAL TUBE SCRAPER LEVER

The product is supplied with the spiral tube scraper lever mounted on the right side; if needed, it can be moved to the left side of the appliance.



This operation must be exclusively performed by qualified professional staff, as set forth by Decree no. 37 of 22nd January 2008 and applicable laws on the subject. Before performing said task, make sure the power supply cable is disconnected from the electrical power socket.

Follow the procedures in the previous chapter up to point 2 to carry out this operation.

4.4 GUIDELINES FOR THE HYDRAULIC SYSTEM



The hydraulic system must be installed by qualified personnel who are familiar with the standards mentioned above and who have the appropriate professional requirements to release the declaration of conformance in accordance with Ministerial Decree n° 37 of 22 January 2008. The system must be suitably sized in relation to the power of the generator.



ATTENTION: it is mandatory to earth the generator. If this instruction is not observed serious damage, which is not covered by warranty, will result to the body of the appliance. Have a skilled electrician check the earthing. There must be no electric potential (Volt) between the generator earth and the plant's real earth (earth plate). To prevent electrochemical corrosion of the appliance body do not use galvanised pipes and fittings. Other materials must be earthed with special earthing cables in order to obtain a unipotential earthing system.

4.5 INSTRUCTIONS FOR EXECUTING THE CLOSED EXPANSION TANK HYDRAULIC SYSTEM

To install the system with a closed expansion tank refer to the requirements laid down in EN 10412-2:2009 for appliances with nominal heat output not exceeding 35 kW or in the Ministerial Decree Collection R edition 2009 for appliances with nominal heat output exceeding 35 kW.

The hydraulic system must be installed by qualified personnel who are familiar with the standards mentioned above and who have the appropriate professional requirements to release the declaration of conformance in accordance with Ministerial Decree n° 37 of 22 January 2008.

A closed expansion tank must be series-connected to the generator as protection for the system.

The nominal volume of the closed expansion tank must be sized in relation to the total volume of the water contained in the system. Thermorossi prescribes the size of the closed expansion tank as equal to 10% of the volume of water contained in the entire system. Any bulging of the boiler body caused by an incorrectly sized expansion tank will not be covered by the warranty.

The next chapter and the preceding chapters do not replace the above mentioned standards to which they refer. The qualified installer must in any case be fully aware of the above standards and their amending versions.

4.6 TYPICAL HYDRAULIC DIAGRAMS

- BOILER WITH PUFFER TANK AND HIGH AND LOW TEMPERATURE SYSTEM

Legenda	Key
RISCALDAMENTO A PAVIMENTO	UNDERFLOOR HEATING
Sonda PUFFER BASSO JP12 pin 9 e 10	Sensor LOWER PUFFER JP12 pin 9 and 10
Sonda PUFFER ALTO JP12 pin 7 e 8	Sensor UPPER PUFFER JP12 pin 7 and 8
RADIATORI	RADIATORS
DALL'ACQUEDOTTO	FROM WATER MAINS
BULBO VST	BULB VST
CALDAIA	BOILER
SCARICO	OUTLET
THERMOPUFFER 1500	THERMOPUFFER 1500
Morsettiera JP2 pin 1 e 2	Terminal block JP2 pin 1 and 2
Morsettiera JP2 pin 5 (marrone), 6 (blu), 7 (nero)	

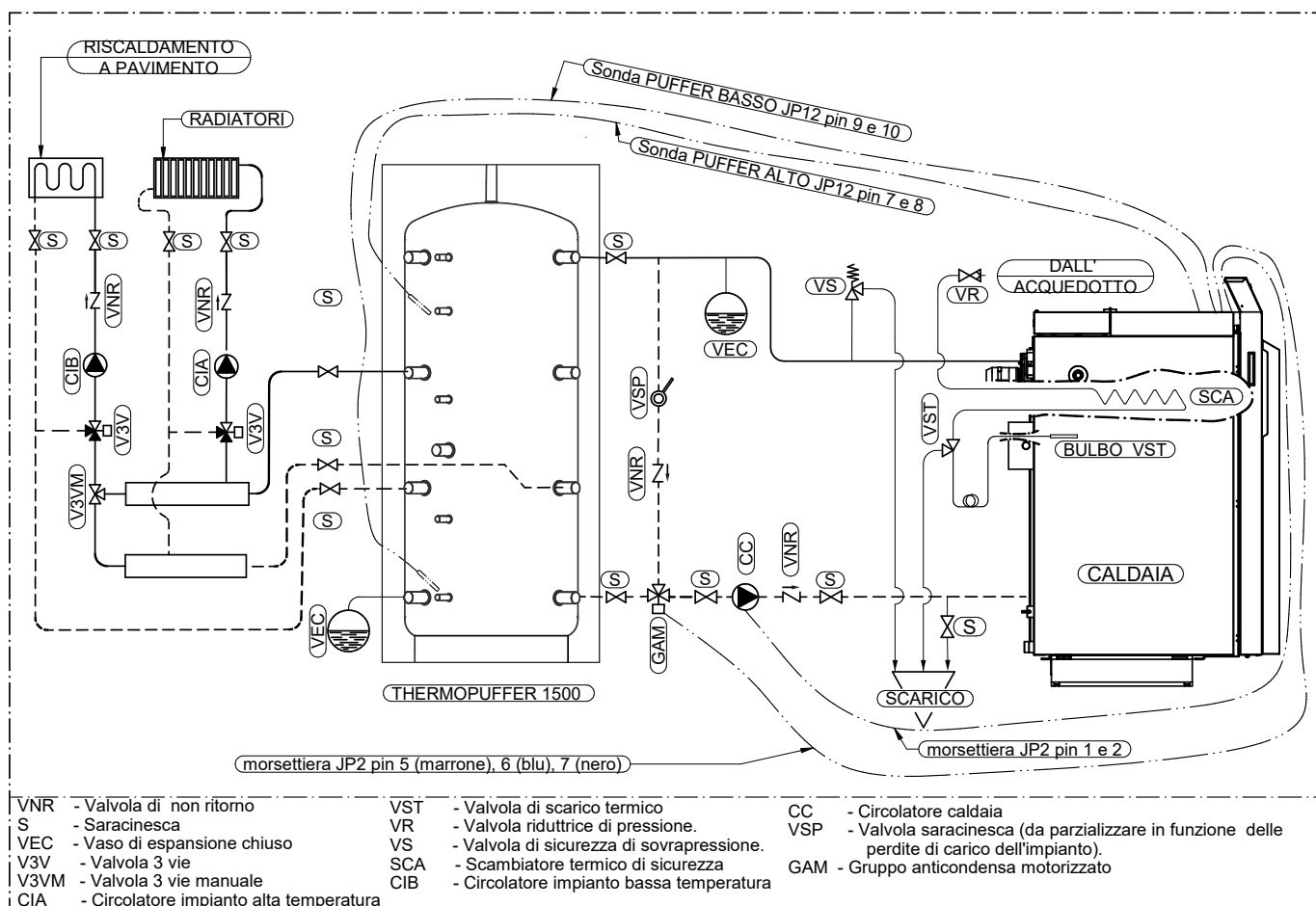

VNR - Valvola di non ritorno	VST - Valvola di scarico termico	CC - Circolatore caldaia
S - Saracinesca	VR - Valvola riduttrice di pressione.	VSP - Valvola saracinesca (da parzializzare in funzione delle perdite di carico dell'impianto).
VEC - Vaso di espansione chiuso	VS - Valvola di sicurezza di sovrappressione.	GAM - Gruppo anticondensa motorizzato
V3V - Valvola 3 vie	SCA - Scambiatore termico di sicurezza	
V3VM - Valvola 3 vie manuale	CIB - Circolatore impianto bassa temperatura	
CIA - Circolatore impianto alta temperatura		

PUFFER 1500 I + CALDAIA + IMPIANTO ALTA TEMPERATURA + IMPIANTO BASSA TEMPERATURA

VNR	Nonreturn valve	VST	Thermal relief valve	CC	Boiler circulating pump
S	Gate valve	VR	Pressure reducing valve	VSP	Gate valve (throttle according to pressure drop in the system)
VEC	Closed expansion tank	VS	Overpressure safety valve	GAM	Motor-operated anticondensation unit
V3V	Three-way valve	SCA	Safety heat exchanger		
V3VM	Manual three-way valve	CIB	System circulator pump, low temperature		
CIA	System circulator pump, high temperature				

PUFFER TANK 1500 I + BOILER + HIGH TEMPERATURE SYSTEM + LOW TEMPERATURE SYSTEM

ATTENTION: before loading the system, it is mandatory to verify that the preload pressure of the expansion tank or expansion tanks is 1.5 bar. Next load the system until it reaches a pressure of 1 bar.

ATTENTION: the following genuine Thermorossi accessories are required to control this system:
2 thermocouples (code no. 60013656) to connect to the terminal block JP12 on pins 7 - 8 (upper puffer sensor) and on pins 9 - 10 (lower puffer sensor).

1 motor-operated anticondensation unit 70030783
1 safety heat exchanger Code 60013727
1 thermal relief valve Code 60012922

With this type of system, you must activate the BOILER + PUFFER TANK configuration in the generator's System Menu. (See the paragraph dedicated to software operation).



ATTENTION: it is mandatory to earth the generator. If this instruction is not observed serious damage, which is not covered by warranty, will result to the body of the generator. Have an electrician check the earthing. There must be no electric potential (Volt) between the earth of the generator and the actual earth of the system. To prevent electrochemical corrosion of the boiler body do not use galvanised pipes and fittings. Dedicated ground wires must be used to ground all other materials.

- BOILER WITH PUFFER TANK AND AUXILIARY GENERATOR CONNECTED WITH A PLATE HEAT EXCHANGER

Legenda	Key
RISCALDAMENTO A PAVIMENTO	UNDERFLOOR HEATING
RADIATORI	RADIATORS
Generatore liquido o gassoso	Liquid or gas generator
Sonda PUFFER BASSO JP12 pin 9 e 10	Sensor LOWER PUFFER JP12 pin 9 and 10
Sonda PUFFER ALTO JP12 pin 7 e 8	Sensor UPPER PUFFER JP12 pin 7 and 8
Consenso accensione morsetteria JP4 pin 1 e 3	Terminal block ON consent JP4 pin 1 and 3
DALL'ACQUEDOTTO	FROM WATER MAINS
BULBO VST	BULB VST
CALDAIA	BOILER
SCARICO	OUTLET
THERMOPUFFER 1500	THERMOPUFFER 1500
Morsetteria JP2 pin 1 e 2	Terminal block JP2 pin 1 and 2
Morsetteria JP2 pin 5 (marrone), 6 (blu), 7 (nero)	

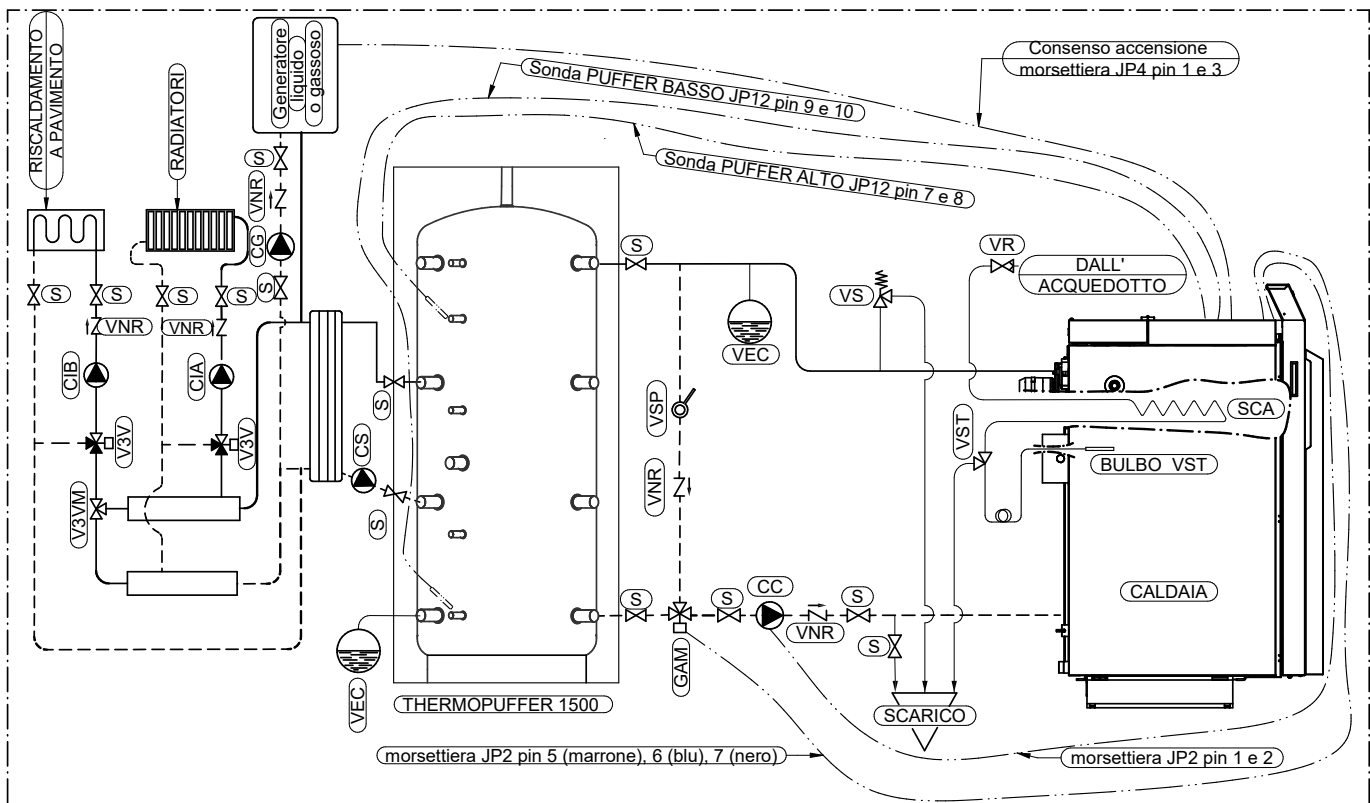

VNR - Valvola di non ritorno	VST - Valvola di scarico termico	CG - Circolatore caldaia aggiuntiva combustibile liquido o gassoso
S - Saracinesca	VR - Valvola riduttrice di pressione.	CC - Circolatore caldaia
VEC - Vaso di espansione chiuso	VS - Valvola di sicurezza di sovrappressione.	VSP - Valvola saracinesca (da parzializ. in funzione delle perdite di carico dell'impianto).
V3V - Valvola 3 vie	SCA - Scambiatore termico di sicurezza	GAM - Gruppo anticondensa motorizzato
V3VM - Valvola 3 vie manuale	CIB - Circolatore impianto bassa temperatura	
CIA - Circolatore impianto alta temperatura	CS - Circolatore scambiatore	

PUFFER 1500 I + CALDAIA + CALDAIA AGG SU IMPIANTO + IMPIANTO ALTA TEMPERATURA + IMPIANTO BASSA TEMPERATURA

VNR	Nonreturn valve	VST	Thermal relief valve	CG	Additional liquid or gas fuelled boiler circulating pump
S	Gate valve	VR	Pressure reducing valve	CC	Boiler circulating pump
VEC	Closed expansion tank	VS	Overpressure safety valve		
V3V	Three-way valve	SCA	Safety heat exchanger	VSP	Gate valve (throttle according to pressure drop in the system)
V3VM	Manual three-way valve	CIB	System circulator pump, low temperature	GAM	Motor-operated anticondensation unit
CIA	System circulating pump, high temperature	CS	Heat exchanger circulating pump		

PUFFER TANK 1500 I + BOILER + ADDIT. BOILER ON SYSTEM + HIGH TEMPERATURE SYSTEM + LOW TEMPERATURE SYSTEM

ATTENTION: before loading the system, it is mandatory to verify that the preload pressure of the expansion tank or expansion tanks is 1.5 bar. Next load the system until it reaches a pressure of 1 bar.

ATTENTION: the following genuine Thermorossi accessories are required to control this system:

2 thermocouples (code no. 60013656) to connect to the terminal block JP12 on pins 7 - 8 (upper puffer sensor) and on pins 9 - 10 (lower puffer sensor).

1 motor-operated anticondensation unit 70030783

1 safety heat exchanger Code 60013727

1 thermal relief valve Code 60012922

When any alarm intervenes - except the 'door open' or 'boiler temperature too high' alarms - the generator enables the start consent for an auxiliary generator.

The auxiliary generator receives the signal to start when contacts 1 and 3 on terminal block JP4 close. These contacts are not powered and therefore are defined as voltage-free contacts.

With this type of system, you must activate the BOILER + PUFFER TANK configuration in the generator's System Menu. (See the paragraph dedicated to software operation).



ATTENTION: it is mandatory to earth the generator. If this instruction is not observed serious damage, which is not covered by warranty, will result to the body of the generator. Have an electrician check the earthing. There must be no electric potential (Volt) between the earth of the generator and the actual earth of the system. To prevent electrochemical corrosion of the boiler body do not use galvanised pipes and fittings. Dedicated ground wires must be used to ground all other materials.

- BOILER WITH PUFFER TANK AND DOMESTIC BOILER TUBE

Legenda	Key
RISCALDAMENTO A PAVIMENTO	UNDERFLOOR HEATING
RADIATORI	RADIATORS
Sonda PUFFER ALTO JP12 pin 7 e 8	Sensor UPPER PUFFER JP12 pin 7 and 8
Sonda PUFFER BASSO JP12 pin 9 e 10	Sensor LOWER PUFFER JP12 pin 9 and 10
Morsettiere JP2 pin 5 e 6	Terminal block JP2 pin 5 and 6
Sonda PT 1000 morsettiere JP12 pin 5 e 6	Sensor PT 1000 terminal block JP12 pin 5 and 6
BOLLITORE SANITARIO 300 L. MINIMO	DOMESTIC BOILER TUBE, MINIMUM 300 L
DALL'ACQUEDOTTO	FROM WATER MAINS
BULBO VST	BULB VST
CALDAIA	BOILER
SCARICO	OUTLET
THERMOPUFFER 1500	THERMOPUFFER 1500
Morsettiere JP2 pin 1 e 2	Terminal block JP2 pin 1 and 2

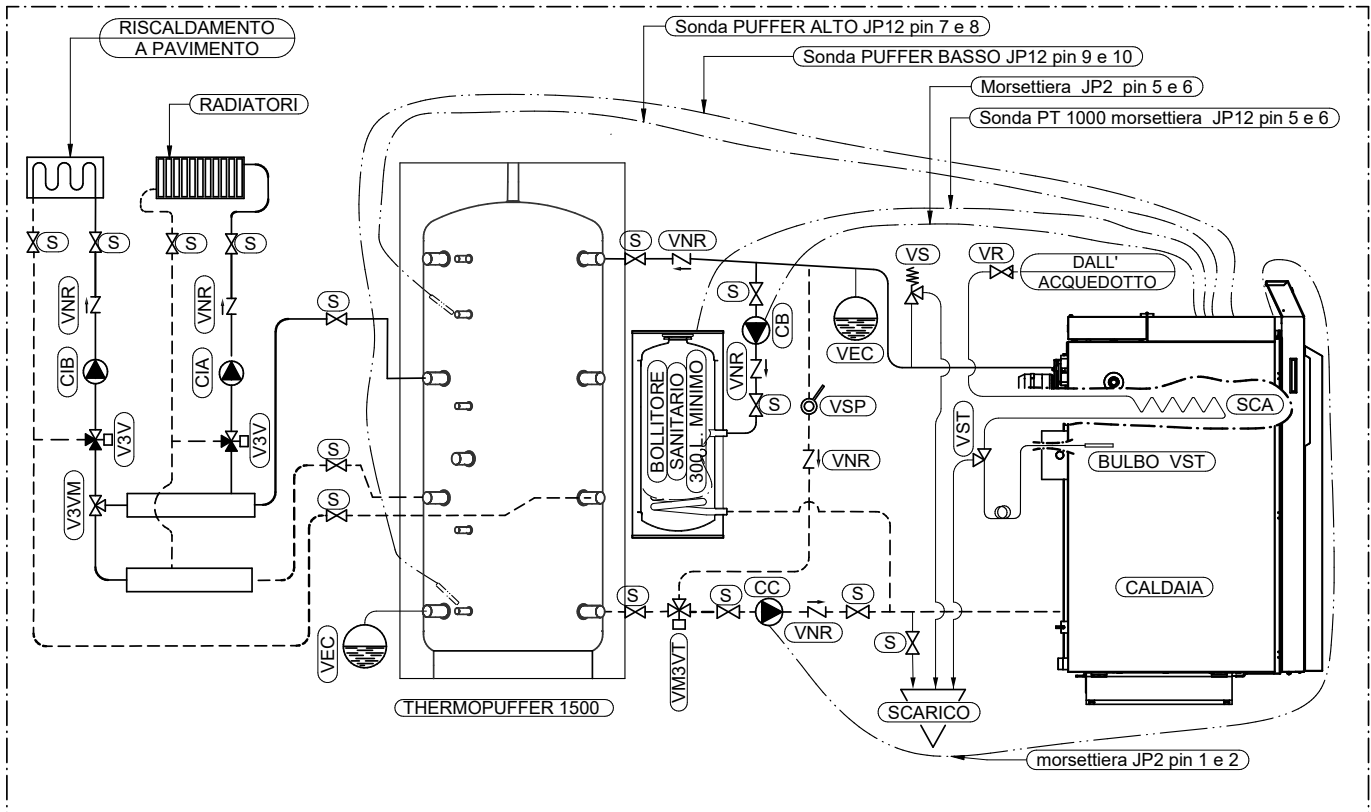

VNR	- Valvola di non ritorno	VST	- Valvola di scarico termico	CG	- Circolatore bollitore sanitario
S	- Saracinesca	VR	- Valvola riduttrice di pressione.	CC	- Circolatore caldaia
VEC	- Vaso di espansione chiuso	VS	- Valvola di sicurezza di sovrappressione.	VSP	- Valvola saracinesca (da parzializzare in funzione delle perdite di carico dell'impianto).
V3V	- Valvola 3 vie	SCA	- Scambiatore termico di sicurezza	VM3VT	- Valvola miscelatrice termostatica punto fisso 55°C 1" 1/2
V3VM	- Valvola 3 vie manuale	CIB	- Circolatore impianto bassa temperatura		
CIA	- Circolatore impianto alta temperatura				

PUFFER 1500 I + CALDAIA + IMPIANTO ALTA TEMPERATURA + IMPIANTO BASSA TEMPERATURA + BOLLITORE SANITARIO

VNR	Nonreturn valve	VST	Thermal relief valve	CG	Domestic boiler tube recirculating pump
S	Gate valve	VR	Pressure reducing valve	CC	Boiler circulating pump
VEC	Closed expansion tank	VS	Overpressure safety valve	VSP	Gate valve (throttle according to pressure drop in the system)
V3V	Three-way valve	SCA	Safety heat exchanger	VM3VT	Thermostatic mixing valve, fixed point 55°C 1" 1/2
V3VM	Manual three-way valve	CIB	System circulator pump, low temperature		
CIA	System circulator pump, high temperature				

PUFFER TANK 1500 I + BOILER + HIGH TEMPERATURE SYSTEM + LOW TEMPERATURE SYSTEM + DOMESTIC BOILER TUBE

ATTENTION: before loading the system, it is mandatory to verify that the preload pressure of the expansion tank or expansion tanks is 1.5 bar. Next load the system until it reaches a pressure of 1 bar.

ATTENTION: the following genuine Thermorossi accessories are required to control this system:

3 thermocouples (code no. 60013656) to connect to the terminal block JP12 on pins 7 - 8 (upper puffer sensor), pins 9 - 10 (lower puffer sensor) and pins 5 - 6 (domestic water boiler tube sensor)

1 mixing valve 55 °C 1" ½ Code 60012979

1 safety heat exchanger Code 60013727

1 thermal relief valve Code 60012922

With this type of system, you must activate the BOILER + PUFFER TANK + BOILER TUBE configuration in the generator's System Menu. (See the paragraph dedicated to software operation).



ATTENTION: it is mandatory to earth the generator. If this instruction is not observed serious damage, which is not covered by warranty, will result to the body of the generator. Have an electrician check the earthing. There must be no electric potential (Volt) between the earth of the generator and the actual earth of the system. To prevent electrochemical corrosion of the boiler body do not use galvanised pipes and fittings. Dedicated ground wires must be used to ground all other materials.

- CONNECTION DIAGRAM OF SANFAST 50 ON THERMOPUFFER 1500

Legenda	Key
SANFAST 50	SANFAST 50
CALDAIA	BOILER
THERMOPUFFER 1500	THERMOPUFFER 1500
S - Saracinesca	S – Gate valve

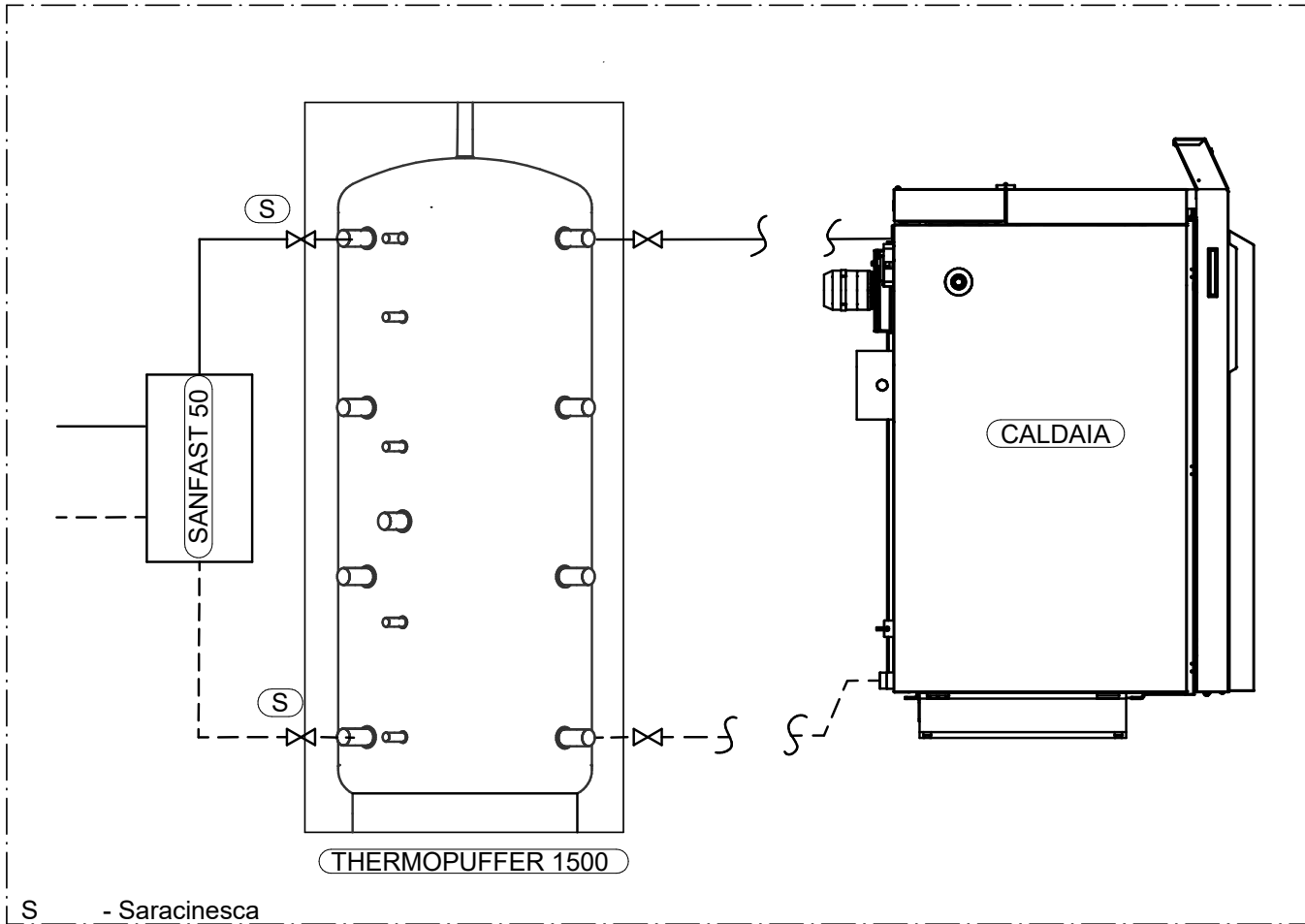

ATTENTION: before loading the system, it is mandatory to verify that the preload pressure of the expansion tank or expansion tanks is 1.5 bar. Next load the system until it reaches a pressure of 1 bar.

With this type of system, you must activate the BOILER + PUFFER TANK configuration in the generator's System Menu. (See the paragraph dedicated to software operation).



ATTENTION: it is mandatory to earth the generator. If this instruction is not observed serious damage, which is not covered by warranty, will result to the body of the generator. Have an electrician check the earthing. There must be no electric potential (Volt) between the earth of the generator and the actual earth of the system. To prevent electrochemical corrosion of the boiler body do not use galvanised pipes and fittings. Dedicated ground wires must be used to ground all other materials.

5 – MOUNTING THE MOTOR-OPERATED ANTICONDENSATION UNIT

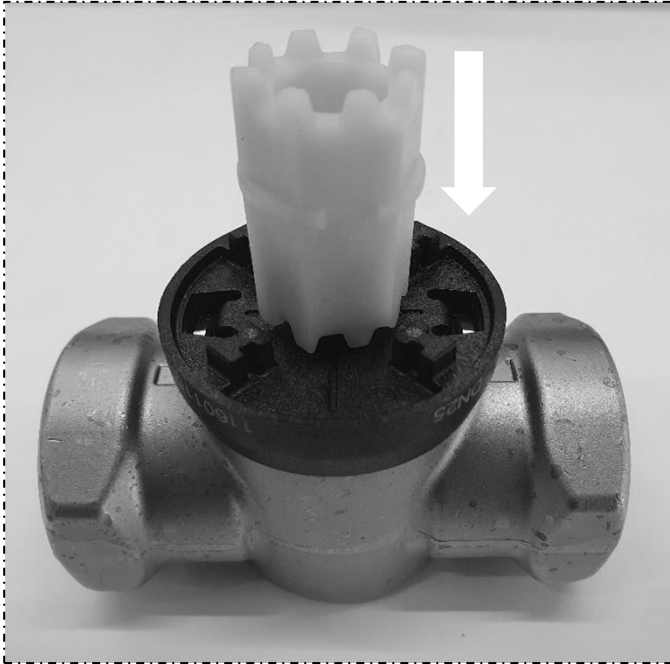

1 – Insert the toothed element inside the valve body until it stops. To do so, insert it from the longer part as shown in the picture above.

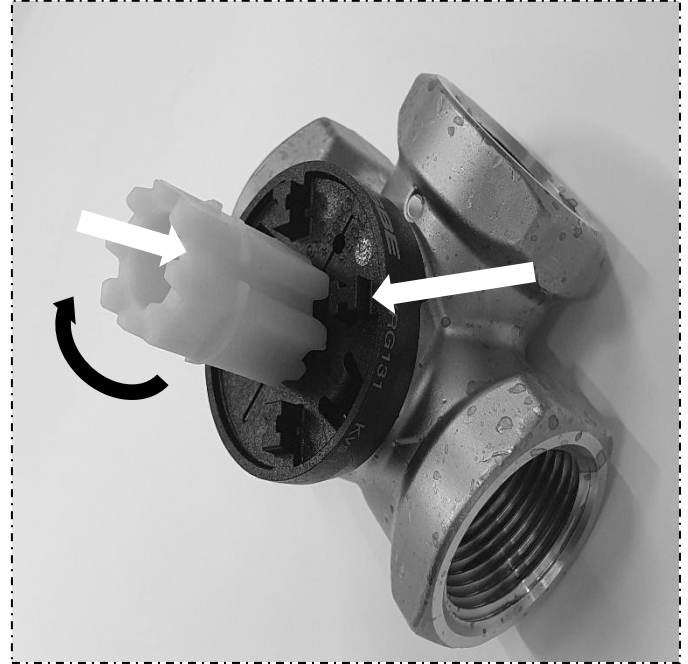

2 – Rotate the toothed element until its groove reaches the valve tooth indicated in the picture above.

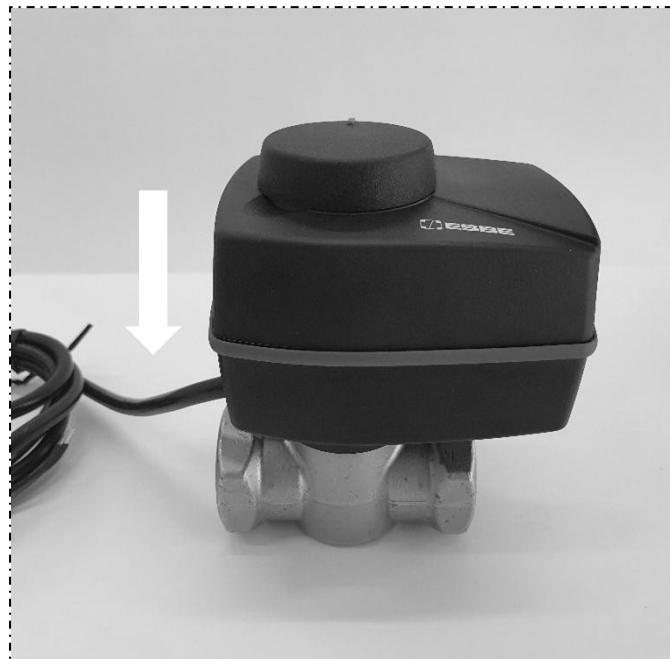

3 – Install the motor on the valve by pushing it downwards until the end stop.



4 – Insert the indicator in the dedicated slot as shown in the photo above and remove the motor cap by pulling it upwards.



5 – Attach the motor to the valve using the Philips head screw provided. Always make sure the position of the rotor and the green tooth are as shown in the picture above.

6 – Insert the cap removed until the end stop by pushing it towards the motor. Afterwards, pull the same cap outwards until you hear a click and the red band is visible, see picture above.

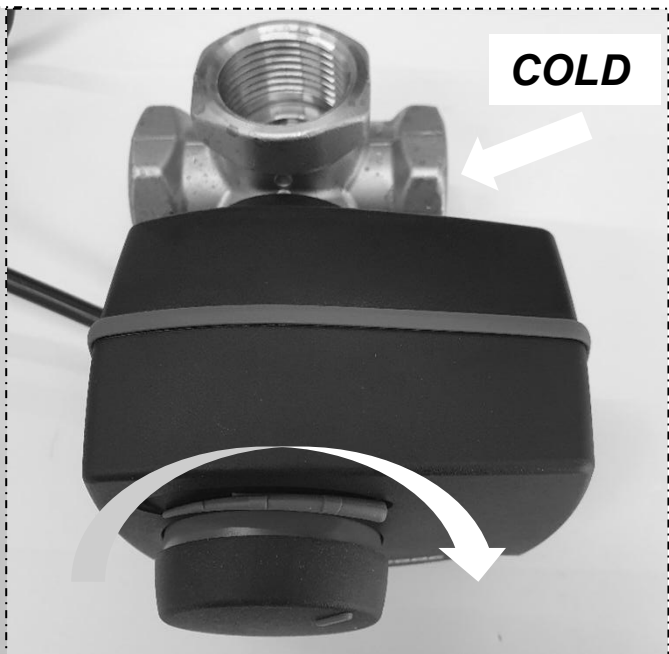

7 – To check whether the installation has been successful, rotate the extracted cap anti-clockwise until the end stop. If the HOT branch is completely closed, then the installation was successful, otherwise start the procedure again.

8 – To check whether the installation has been successful, rotate the extracted cap clockwise until the end stop. If the COLD branch is completely closed, then the installation was successful, otherwise start the procedure again. Push the cap inwards until the red band disappears.

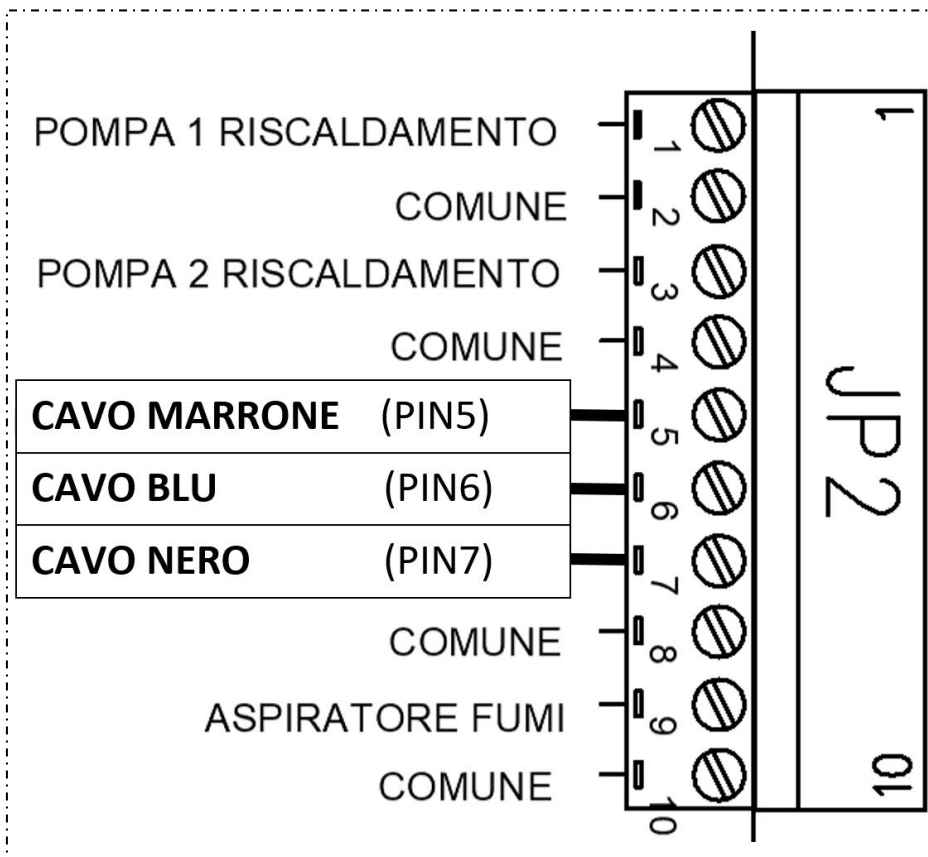

9 – Electrically connect the motor-operated anticondensation unit to the electronic board of the device following the diagram above. Finally, activate the Mixing Valve function from the display by turning the value to ON (see paragraph 6.2).

Legenda	Key
POMPA 1 RISCALDAMENTO	PUMP 1 HEATING
COMUNE	COMMON
POMPA 2 RISCALDAMENTO	PUMP 2 HEATING
COMUNE	COMMON
CAVO MARRONE (PIN 5)	BROWN CABLE (PIN 5)
CAVO BLU (PIN 6)	BLUE CABLE (PIN 6)
CAVO NERO (PIN 7)	BLACK CABLE (PIN 7)
COMUNE	COMMON
ASPIRATORE FUMI	SMOKE SUCTION UNIT
COMUNE	COMMON



ATTENTION: it is not possible to use the motor-operated anticondensation unit in the presence of a domestic boiler tube. In this case, an adjustable anticondensation valve code 60012979 must be installed.

6 – USE OF THE GENERATOR



The appliance, when in operation, is hot to the touch and the feed door is extremely hot: consequently, take care. Your appliance has obtained the CE marking. The product must not be used by children, by persons with physical or mental impairments, by persons who are not familiar with the instructions for use and maintenance of the product (the instructions are found in this booklet).



ATTENTION: the doors must always remain shut tight when the appliance is operating. It is strictly forbidden to open the door while the flame is still burning. During operation the smoke exhaust pipes and the boiler can reach extremely high temperatures: do not touch them! To light the appliance, it is permitted to use specific fuel for lighting wood fired boilers: it is strictly forbidden to use explosive, liquid or gas fuels or any other fuels apart from those permitted. Do not place non-heat resistant, inflammable or combustible objects in the vicinity of the boiler: keep them at a suitable distance. Do not place wet clothing to dry on the appliance. When using a clothes horse, keep at a suitable distance. It is strictly prohibited to disconnect the boiler from the electrical power mains during operation.



ATTENTION, VERY IMPORTANT: for your safety we recommend you do not open the combustion chamber door when there is a flame present in the boiler.

6.1 CONTROL PANEL

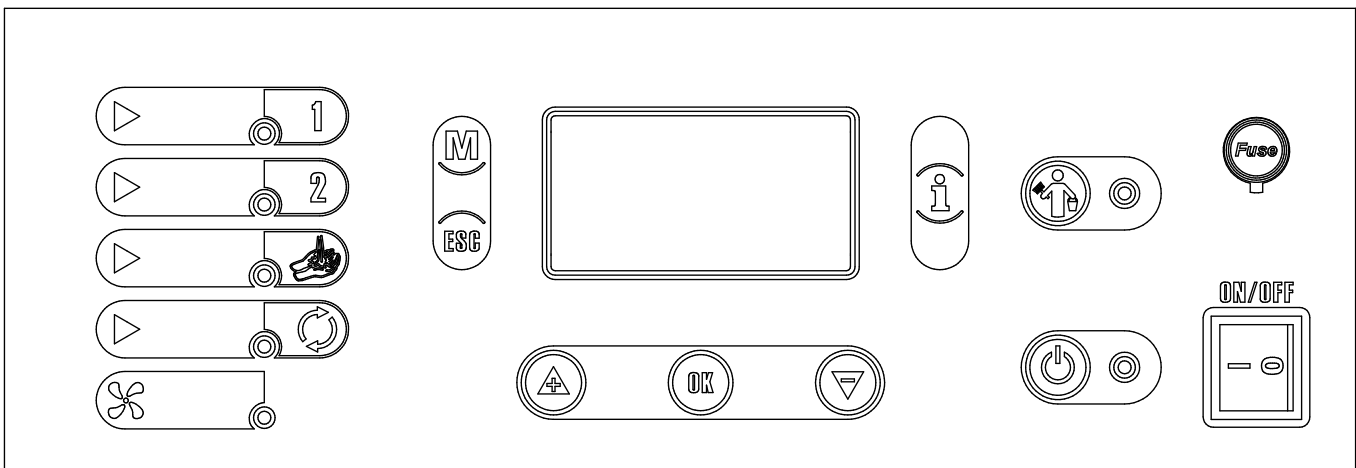

The control panel is managed by a microprocessor. The temperature detection system uses thermocouples. The large display improves the appliance management by making read-outs and functions promptly available. The various control buttons are described below.



Main switch 0/I



Start button

Press this button to start the operating cycle.



Menu button

Press this button to access the main Menu. Various screens, described in the following paragraphs, can be viewed.



ESC button

Press this button to go back to the previous screen of the Menu.



OK button

This button enables you to enter the various Menu windows or confirm a selection.



Scroll buttons

Use the + button to increase the preset value or to scroll upwards.
Use the – button to decrease the preset value or scroll downwards.



INFO button

Press this button to display error messages.
If there are no active error messages the date and time will appear.



EMBERS button

Press this button to deactivate the ember maintenance function (Red LED on).
Press again to activate this function (Red LED off).

On the left of the control panel there are 5 indicator symbols with corresponding LED.



CIRCULATING PUMP 1

When the LED lights up, heating pump 1 or the puffer tank pump is activated.



CIRCULATING PUMP 2

When the LED lights up heating pump 2 is activated.



ACS CIRCULATING PUMP (Domestic hot water)

When the LED lights up, the domestic water boiler tube pump is activated.



CIRCULATING PUMP

When the LED lights up the recirculating pump is activated.



SMOKE SUCTION UNIT

When the LED lights up the smoke extractor is activated.

6.2 DISPLAY MENU

To access the menu simply press the **Menu Button** in the main screen. The following screen will appear:

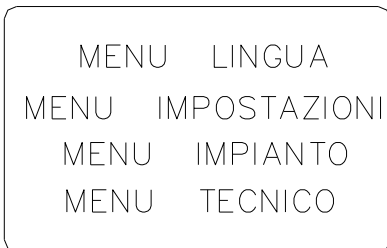

Legenda	Key
MENU LINGUA	LANGUAGE MENU
MENU IMPOSTAZIONI	SETTINGS MENU
MENU IMPIANTO	SYSTEM MENU
MENU TECNICO	TECHNICAL MENU

It is possible to scroll the menu up or down using the **Scroll Buttons**. To confirm a selection or a value simply press the **OK Button**.

LANGUAGE MENU

Select THE LANGUAGE MENU to choose your preferred language setting: Italian, English, German, French, Spanish.
Move onto the desired language by means of the **Scroll Buttons** and confirm by pressing the **OK Button** on the desired language.

SETTINGS MENU

Select the SETTINGS MENU to set the date and time, enter the serial number and change various parameters.

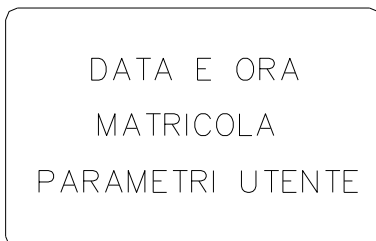

Legenda	Key
DATA E ORA	DATE AND TIME
MATRICOLA	SERIAL NUMBER
PARAMETRI UTENTE	USER PARAMETERS

DATE AND TIME

When you select DATE AND TIME the following dialogue box appears:

Data -> 01 Gennaio 20..

Ora -> 08:10

Legenda	Key
Data--> 01 gennaio 20..	Date--> 01 January 20..
Ora --> 08:10	Time --> 08:10

The day of the month will blink, and to change it simply press the **Scroll Buttons**, then confirm by pressing the **OK Button**. Once it has been confirmed the month will begin to blink; to change it simply press the **Scroll Buttons**, then confirm by pressing the **OK Button**. Once it has been confirmed the year will begin to blink; to change it simply press the **Scroll Buttons**, then confirm by pressing the **OK Button**. Once it has been confirmed the hour will begin to blink; to change it simply press the **Scroll Buttons**, then confirm by pressing the **OK Button**. Once it has been confirmed the minutes will begin to blink; to change it simply press the **Scroll Buttons**, then confirm by pressing the **OK Button**.

SERIAL NUMBER

The Serial Number can only be set by an Authorised Service Centre during the initial commissioning stage.

USER PARAMETERS

When you select USER PARAMETERS the following screen appears:

Temperat. ACS Max. 60

Temperat. ACS Min. 40

Cicalino (0=Off) 0

AUX mode (1=Rev.) 0

Legenda	Key
Temperat. ACS Max 60	Temperat. Domestic hot water (ACS) Max 60
Temperat. ACS Min 40	Temperat. Domestic hot water (ACS) Min 40
Cicalino (0=Off)	Buzzer (0=Off)
AUX mode (1=Rev.)	AUX mode (1=Rev.)

In this screen you can set the preferred control temperatures of the domestic hot water boiler tube (if installed).

Two values will appear, one for the maximum temperature and one for the minimum temperature.

When the water reaches the maximum temperature the recirculating pump of the boiler tube deactivates, whereas when it reaches the minimum temperature the recirculating pump of the boiler tube activates, but only if the water temperature in the generator is over 61°C.

We recommend having the Authorised Service Centre carry out this adjustment during the initial commissioning stage.

Buzzer and Aux mode are two parameters to be left at 0.

SYSTEM MENU

When you select SYSTEM MENU the following screen appears:

Caldaia +Puf. +acs

Caldaia +Puf. ●

Caldaia +acs

Solo Caldaia

V. Miscelatrice Off

Legenda	Key
Caldaia + Puf + acs	Boiler + Puffer Tank + Domestic Hot Water (ACS)
Cladaia + Puf	Boiler + Puffer Tank
Caldaia + acs	Boiler + Domestic Hot Water (ACS)
Solo Caldaia	Only Boiler
V. Miscelatrice	Mixing valve

The various system types can be selected in this screen. We recommend having the Authorised Service Centre carry out this adjustment during the initial commissioning stage. The available selections are:

- BOILER + PUFFER TANK + DOMESTIC HOT WATER (ACS)
- BOILER + PUFFER
- BOILER + DOMESTIC HOT WATER (ACS)
- ONLY BOILER
- MIXING VALVE (ON or OFF)

To set the desired system simply select it with the **Scroll Buttons** and confirm by pressing the **OK Button**.

An initial confirmation is requested:

Attention change of system type from to Confirm

When you press the **OK Button** a second confirm request appears:

The new system that has been selected is:.....

When the **OK Button** is pressed you return to the system menu and the selected system will have a black dot next to it on the right.

TECHNICAL MENU

Only an Authorised Service Centre can access this menu.

6.3 STARTING THE GENERATOR

Power up the appliance by pressing the **Start Button**.

Arrange a small amount of rather thick dry firewood (3–4 cm diameter) in the centre of the burner; then place thinner pieces of wood on top of this pile, and lastly place a generous amount of newspaper or firelighter and light it.

After a few minutes, when the wood begins to burn and a layer of embers has formed, load the wood by arranging it in an orderly fashion, making sure that the fuel sits uniformly on the burner plate and that the empty spaces inside the combustion chamber are as few as possible.

This initial combustion stage could take several minutes.

IMPORTANT: WHEN RELOADING THE BED OF EMBERS IN THE BOILER ON WHICH THE LOGS ARE PLACED MUST NOT EXCEED 5 CM; THIS WILL ENSURE OPTIMUM POWER DELIVERY AND MAINTAIN HIGH EFFICIENCY.

6.4 RELOADING THE FIREWOOD

Use the supplied poker to spread the embers and remaining logs out evenly to a height that does not exceed 5 cm; any higher and the generator power would be severely limited.

Arrange the logs so that they are positioned evenly on the burner plate and the empty spaces in the combustion chamber are minimised. The maximum limit for a load of firewood is determined by the height of the ceiling in the combustion chamber.

6.5 PRACTICAL SUGGESTIONS AND INFORMATION

When the water temperature inside the boiler exceeds 90°C the smoke extractor is brought to a forced stop. For this reason, the wood load must always be suited to the actual thermal absorption needs of the system: large fuel loads in limited absorption conditions lead to shutdown of the smoke extractor and consequently result in unburnt wood remaining for long periods on the layer of embers. This situation provokes the distillation of the wood with the subsequent formation of considerable quantity of gases and vapours that do not get burned. The gases and vapours generated by the distillation tend to condense inside the boiler to form thick layers of tar that could even leak outside and considerably dirty the exterior. To avoid this situation, it is mandatory to load small amounts during the in-between seasons period in order to completely burn the entire load in the time required to take the system to the steady state, without overheating the generator.

In any case if the load level in the puffer tank indicated on the display exceeds 50% only make a partial reload.



Important warning: when the smoke extractor is not operating do not open the loading door.

In this situation the unburnt gases lacking oxygen, could catch fire immediately when fuelled with fresh air entering through the open door, causing a dangerous situation for the user.

6.6 OPERATING CYCLE

To power up the generator press the **Start Button**.

The smoke extractor starts operating.

The pre-heating stage ends as soon as the smoke reaches an adequate temperature; the operating cycle then passes on to the work stage. During the work stage the smoke suction unit and the servomotors continually regulate the primary and secondary air based on the temperature of the smoke, the water temperature and the oxygen content detected by the Lambda sensor.

When the temperature reaches 61°C the generator enables the recirculating pump to start.

If the water temperature exceeds 85°C during operation, a flashing “i” will appear on the display and “**High boiler temp. draw more heat**” will appear when pressing the **Info button**. In this phase the generator will automatically activate the minimum steady state power level until the water temperature has dropped below a suitable temperature.

If during the operating cycle the water temperature exceeds 90°C the smoke suction unit stops and the primary and secondary air servomotors automatically close completely. Moreover, the generator activates a forced consent to activate the recirculating pumps connected to it, in an attempt to dissipate the excess heat.

The smoke suction unit will only start up again if the water temperature drops below a suitable temperature.

If on the other hand the water temperature continues to rise until it reaches the calibrated temperature for the thermal relief valve, the latter will activate.

Moreover, if the water exceeds the calibrated temperature of the reset thermostat the smoke suction unit stops operating. A red light will turn on.

When you press the **Info Button** the **RESET THERMOSTAT ALARM** appears.

LAMBDA S29 – S35 – S46 EVO5

Reset the appliance by unscrewing the plastic cover on the thermostat and press the reset button but only after you have verified and found a solution for the problems that led to the overtemperature (the temperature of the appliance must necessarily have dropped considerably).

The cover over the reset button is located at the front as shown in the following figure:

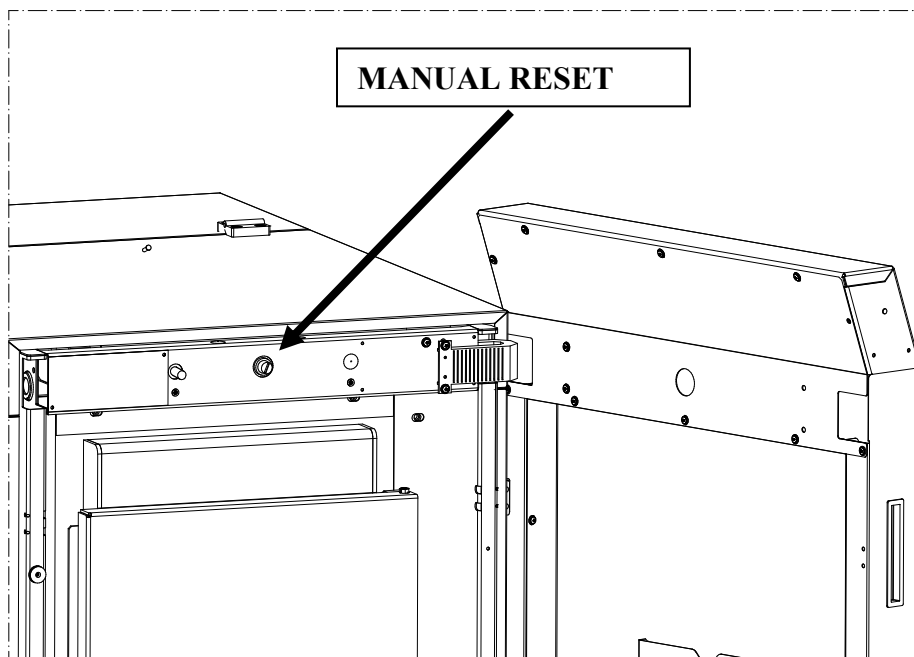

6.7 EMBER MAINTENANCE

It is possible to activate or deactivate the ember maintenance function after combustion.

To activate this function, press the **Ember Button (RED LED OFF)**.

In this case when the firewood load is finished and the FUEL FINISHED EXECUTE CLEANING alarm appears on the display, the smoke suction unit deactivates after a few seconds and the servomotors are closed in order to maintain the embers inside the combustion chamber.

To deactivate this function, press the **Ember Button (RED LED ON)**.

In this case when the firewood load is finished and the FUEL FINISHED EXECUTE CLEANING alarm appears on the display, the smoke suction unit deactivates and the servomotors remain open.

In both conditions the FUEL FINISHED EXECUTE CLEANING alarm will appear on the display.

ATTENTION: this function can be activated or deactivated at any time during the operating cycle.

6.8 DOOR STROKE LIMIT MICROSWITCH

An "i" will start flashing on the display whenever the casing door is open. If the door is closed the "i" continues to flash until the **Info Button** is pressed; at this point the DOOR OPEN message appears and pressing the **OK Button** resets the alarm.

Moreover, when the casing door is opened, the microswitch activates the smoke suction unit to the maximum rotation setting if it is not already in that state. It will return to steady-state operation as soon as the door is closed.

7 – CLEANING AND MAINTENANCE

7.1 FOREWORD



Before beginning any operation ensure that the appliance is off and unplugged from the electrical power socket. Your generator runs on solid fuel: consequently, it requires frequent control and general cleaning operations. This will guarantee regular operation and optimal output at all times. If the product is unused for a prolonged period of time it is mandatory to inspect the smoke channel and outlet to ensure that there are no obstructions before use. It is important to carefully follow the instructions set out below: failure to observe these instructions could cause serious damage to the product, to the system, to objects and to persons using the generator. Caution: do not wet the appliance and do not touch the electrical parts with wet hands. Never vacuum hot ash: this could damage the vacuum device. All the cleaning operations described in this manual must be carried out when the appliance is cold.



7.2 CLEANING AND MAINTENANCE OF THE GENERATOR

EVERY 3 DAYS clean the ash compartment using the rake (figure A) to remove ash deposited in the cast iron compartment. The compartment, consisting of 3 pieces made of refractory cast iron, collects the ash and dust coming from the burner. The ash compartment must always be firmly positioned on the rear part of the generator. Make sure this area is thoroughly cleaned as otherwise this could reduce the heat exchange to the water and consequently the boiler performance.

EVERY 3 DAYS activate the tube scraper lever located on the side of the boiler several times (Figure B).

EVERY WEEK clean the entire burner; small cracks in the refractory bricks do not affect the optimal operation of the boiler in any way whatsoever. Slight curvature and/or wear of the cast iron plates do not affect the correct operation of the generator.

EVERY WEEK inspect and clean the smoke suction unit impeller (see figure C). Clean off any dust from the blades and the walls of the combustion chamber; good quality wood fuel will generate only a small quantity of dust on the blades. Remove any deposits from the smoke suction unit seat. ATTENTION: always ensure that the gasket is in good condition, otherwise it will be necessary to contact an authorised technical support centre for replacement.

EVERY 3 MONTHS clean the tube bundle installed at the rear (figure D), using the supplied steel brush. To clean the tube bundle you firstly need to remove the tube bundle cleaning unit, by removing the pin and pulling out the lever.

AT LEAST TWICE A YEAR clean the flue outlet and pipes. If there are any horizontal sections, inspect them and clean out any ash and soot deposits before they block the passage of the flue gases.

EVERY END OF SEASON do a general cleaning of the combustion chamber, the ash compartment and the tube bundle. It is also advisable to have an Authorised Service Centre perform a general control of the appliance.



A vacuum device simplifies the ash cleaning procedure. The boiler must be completely cooled down before the side panel can be cleaned with a soft cloth and water.



ATTENTION: the generator, the smoke channel and flue outlet must be cleaned in accordance with the specifications described above and use of inflammable products is strictly forbidden: using inflammable products can create dangerous situations. Failure to carry out the necessary maintenance or if only partial maintenance is carried out will affect the correct functioning of the appliance. Any problems resulting from total or partial lack of maintenance will immediately void the warranty.



ATTENTION: if the appliance remains inactive (not used for more than one month) the generator, the smoke discharge tube and the flue outlet must be cleaned out thoroughly and checked for any obstructions (e.g., bird nests) before restarting.

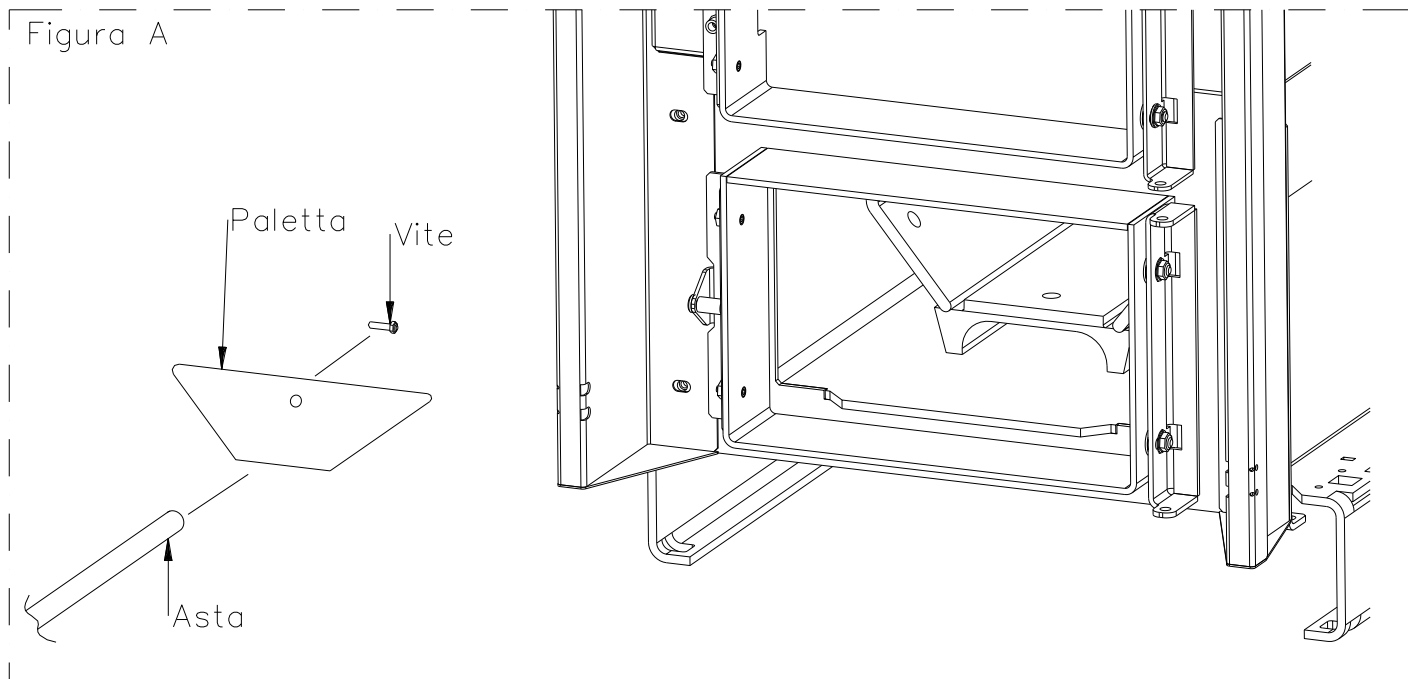

Legenda	Key
Figura	Figure
Paletta	Rake blade
Vite	Screw
Asta	Rod
Aggancio	Hook
Connettore	Connector

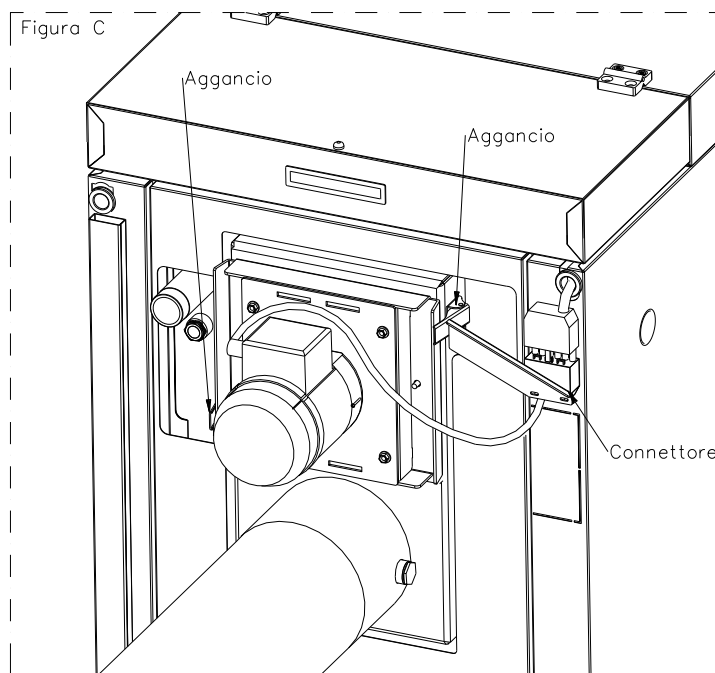
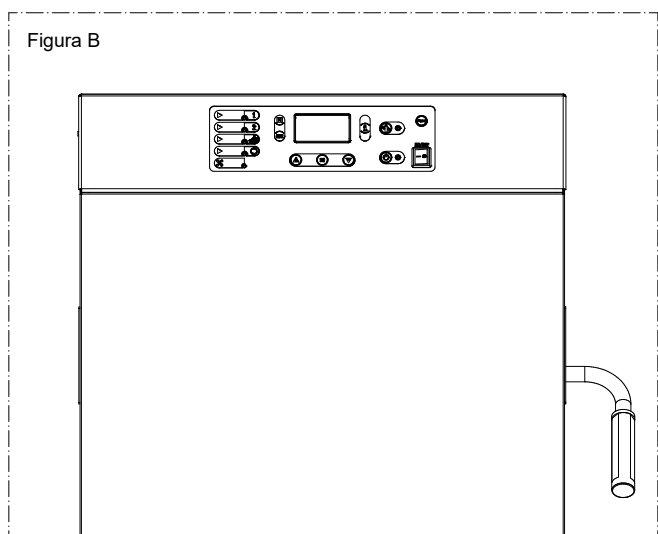

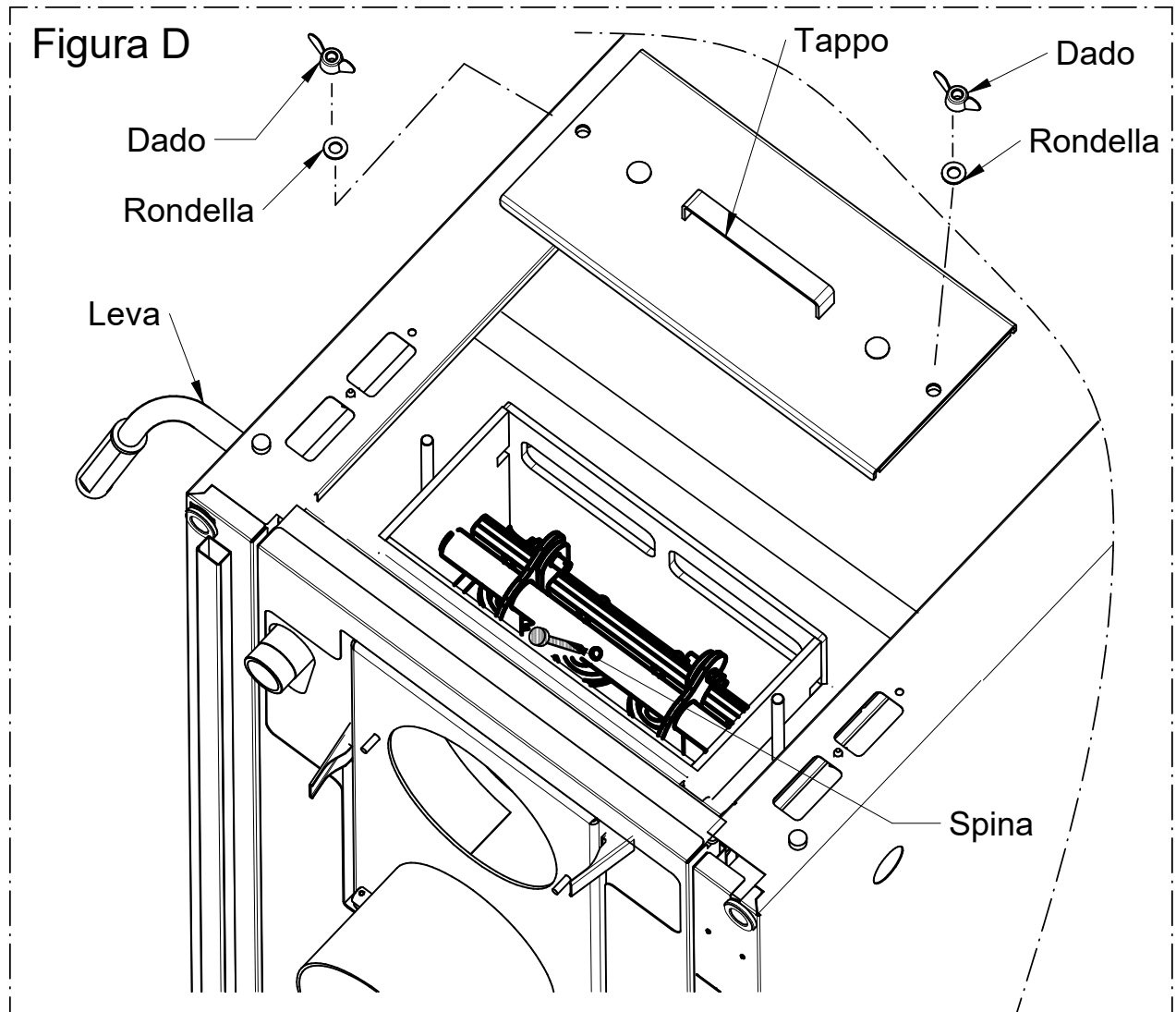

Legenda	Key
Figura D	Figure D
Tappo	Plug
Dado	Nut
Rondella	Washer
Leva	Lever
Spina	Pin

8 – ALARMS

The appliance is programmed to communicate the alarms. A blinking “i” on the display indicates that an alarm has tripped.

To read the error message simply press the **Info Button**.

To reset an alarm, press the **Info Button** followed by the **OK Button** within three seconds.



ATTENTION: the appearance of one of the alarms described below, does not necessarily imply a defect in the product, but simply Thermorossi S.p.A.'s intention to inform the user of the need for corrective actions in order to guarantee maximum safety, greater reliability and high performance of the appliance.

The alarms are listed below:

DOOR OPEN

Indicates that the casing door has opened during the running cycle.

RESET THERMOSTAT ALARM

This appears when the water temperature in the appliance exceeds 95°C. After having verified and solved the causes for the overtemperature, unscrew the plastic cover of the reset thermostat and press the reset button (the appliance can only be reset when its temperature has dropped considerably).

SMOKE SUCTION UNIT ENCODER ALARM

This trips when the smoke suction unit rotation sensor detects a very low or no rotation speed: check the flue pipes and outlet. If the problem persists contact the technical assistance service.

CONTROL ELECTRONICS ALARM

Trips when the generator does not communicate with the primary and secondary air servomotors. Contact the technical service centre.

LAMBDA SENSOR ALARM

Trips when the generator does not communicate with the Lambda Sensor. Contact the technical service centre.

TEMPERATURE SENSOR ALARM

Trips when the generator does not communicate with the temperature sensors. Contact the technical service centre.

BOILER TEMP. TOO HIGH DRAW MORE HEAT

Appears when the water in the appliance has overheated to above 85°C. Do not load any further wood until the temperature lowers considerably. If there are any room temperature thermostats set them to the maximum temperature to ensure that the heat dissipates. The alarm will automatically reset only when the generator temperature drops below a pre-set threshold.

LIGHTING FAILURE REPEAT PROCEDURE

This message appears if the smoke has not reached the required temperature within 50 minutes of the lighting phase. Repeat the lighting procedure.

GENERAL CLEAN ALARM

This appears every 30 hours of operation to remind you to clean the generator. Clean the generator and reset the alarm by pressing the **OK Button**.

FUEL FINISHED EXECUTE CLEANING

This appears if during the operating cycle the smoke temperature and the water temperature have dropped below the preset threshold: this means that the appliance is shutting down due to lack of fuel. Add fuel.

COMMUNICATION INTERRUPTION

It trips when the board does not communicate with the control panel. Contact the technical service centre.

TEMP. H2O <45°C FOR MIN

Trips when the temperature of the generator return water drops below 45°C for 15 minutes. Contact the technical service centre.

9 – SMOKE DISCHARGE TUBE



The smoke channel, the exhaust pipe, chimney and flue outlet (defined as the system for the evacuation of combustion products), are parts of the heating system and they must comply with the legislative requirements of the Ministerial Decree DM 37/08 (ex Italian Law 46/90) and to the applicable specific installation regulations, according to the type of fuel. This product must not be installed in locations where gas appliances type A and type B are present and operating (for the classification see UNI 10642 and UNI 7129). The connection between the appliance and the flue outlet must only receive exhaust from one heat generator.



The appliance is equipped with a smoke exhaust motor, it works in low pressure and with very low smoke temperatures, consequently it is recommended to insulate it and to ensure that the flue outlet is sized appropriately in order to avoid the possible risk of creating condensation.

Every chimney must have minimum number of components as laid down by standard UNI EN 1443 which are also indicated in the figure below:

Components and accessories of a chimney

Key

- 1 Chimney
- 2 Flow path
- 3 Smoke discharge tube
- 4 Thermal insulation
- 5 External wall
- 6 Outer lining
- 7 Flue outlet section
- 8 Multiwall chimney
- 9 Connector
- 10 Flue pipe
- 11 Heat generator

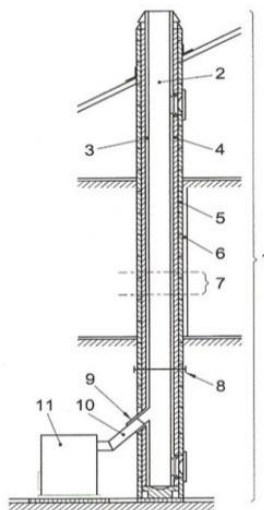

ATTENTION: wall outlets, that is outlets installed on the outer front wall without the use of a chimney/flue outlet /flue pipe to convey the combustion products to the roof, are strictly prohibited.

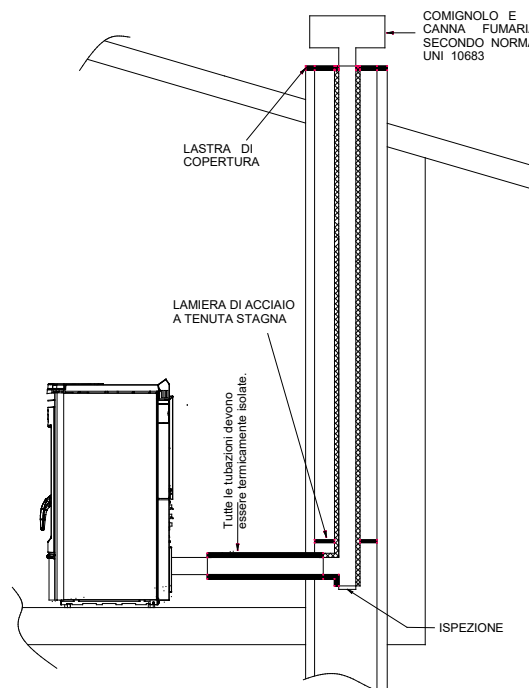
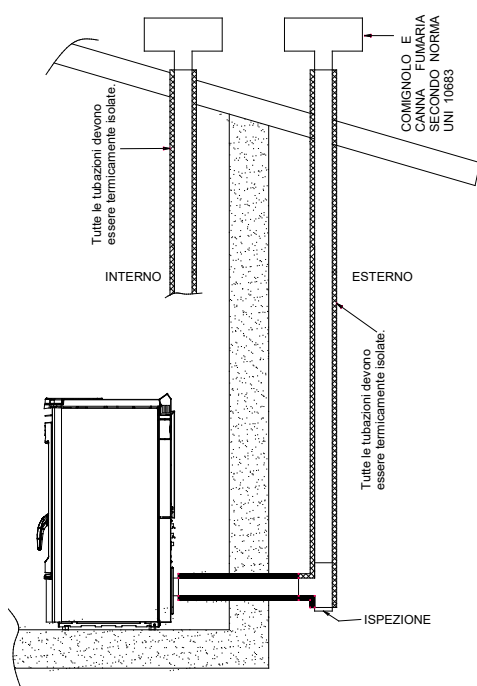

The user must possess a certificate of conformance for the flue outlet (Ministerial Decree 22 January 2008, no. 37). **The flue outlet must be built in compliance with UNI 10683.**

LEGENDA	KEY
COMIGNOLO E CANNA FUMARIA SECONDO NORMA UNI 10683	CHIMNEY CAP AND FLUE OUTLET ACCORDING TO UNI 10683 STANDARD
Tutte le tubazioni devono essere termicamente isolate	All the pipes must be thermally insulated
ISPEZIONE	INSPECTION
ALTEZZA SUPERIORE A 4 metri	HEIGHT MORE THAN 4 m.
Pendenza non inferiore al 5%	Minimum slope 5%
2 metri MAX	2 metres MAX
2-3 metri MAX	2-3 metres MAX.
INTERNO	INTERNAL
ESTERNO	EXTERNAL
LAISTRA DI COPERTURA	COVER SLAB
LAMIERA DI ACCIAIO A TENUTA STAGNA	WATERTIGHT STEEL SHEET

The smoke discharge shown in the following figures is the best solution to ensure the discharge of smoke even when the smoke suction unit is not operational, such as for example if there is an electrical power failure. A minimum drop of 2/3 metres is required between the T terminal on the outside of the building and the outlet at the back of the generator, to ensure that residual combustion smoke is discharged in the case described above (otherwise the residues would stagnate inside the firebox and exhaust into the environment with added the possibility of explosions). The figures illustrate the best solution for discharging the smoke out through the roof or into the flue outlet.

If you prefer to exhaust the smoke from the roof insert a union tee with inspection cap, connecting brackets suitable for the height of the flue outlet, flashing that crosses the roof and chimney cap to protect against bad weather conditions.

If you decide to use the classic masonry exhaust provide a union tee with inspection cap and suitable supporting brackets.

If the flue outlet is too big it is necessary to insert a stainless steel or porcelain-coated steel tube. Seal area where the inlet and outlet part of the smoke exhaust meets the wall. It is strictly forbidden to apply mesh to the end of the outlet tube, as it could cause the appliance to malfunction.

If the smoke tube is installed in a fixed position, it is advisable to provide inspection openings for clean-out purposes especially in the horizontal sections. See the diagram. These openings are essential to allow for the removal of ash and unburned products which tend to accumulate along the discharge path. The appliance functions with the combustion chamber in a vacuum, while the discharge of smoke to the flue outlet has a slight pressure, consequently it is imperative to ensure that the discharge system is hermetically sealed.

The smoke discharge tube must be made from suitable materials such as for example: porcelain-coated steel tubes, with the various fittings sealed with red silicone (resistant to 350°C). The outer casing of the tube must be made with insulating material (mineral wool, ceramic fibre) or use pre-insulated tubing.

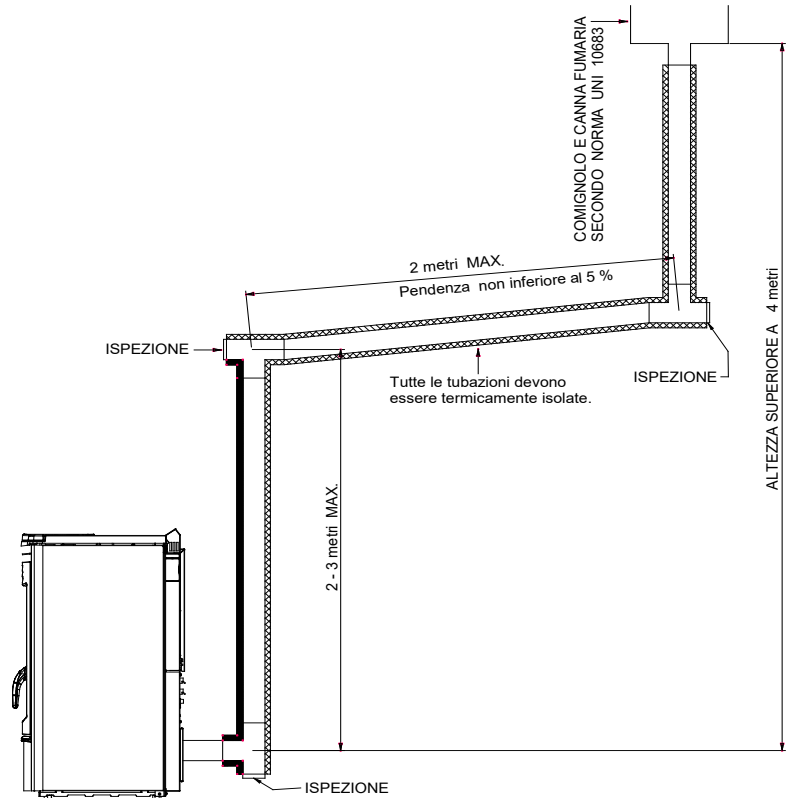

THE FLUE OUTLET MUST BE USED ONLY FOR THE APPLIANCE.



It must be possible to inspect and remove all the smoke tube sections for clean-out purposes.
ATTENTION: if the flue outlet is not sufficiently insulated and /or if it is too long it could generate condensation. It is advisable to provide a condensation drain near the smoke outlet of the appliance. The appliance must always and only be installed in a single flue outlet system dedicated exclusively to the appliance.
If the generator is connected to a non-compliant flue system the appliance could rapidly deteriorate due to an abnormal, continuous overheating: in this case the damaged parts will not be covered by warranty.

IF THE CHIMNEY CATCHES FIRE DO NOT HESITATE TO CALL THE FIRE BRIGADE IMMEDIATELY.



THIS CHAPTER DOES NOT REPLACE THE REFERENCE TECHNICAL STANDARDS.

EMISSION CONTROL:

A sampling point has been provided in the smoke exhaust collar identified with the letter F in the paragraph dedicated to the main boiler parts. The sampling point is sealed with a bolt and sealing gasket; once the emission control has been carried out it is advisable to check the seal on the gasket and replace it if necessary.

10 – ROOM VENTILATION



ATTENTION: the presence of extraction fans or similar appliances, if operating in the same room or space in which the product is installed, could cause problems for the correct operation of the product.
 ATTENTION: do not obstruct the vents or the air inlets on the appliance.

The room where the appliance is installed must have a good air flow to guarantee air for the generator for the combustion process and for ventilation of the room. The natural air flow must take place directly through permanent openings on the outer walls or through single or multiple ventilation ducting.

The ventilating air must come from outside and if possible, away from sources of pollution. The openings in the walls must comply with the following conditions:

- have an unobstructed section of at least 6cm² for each Kw of installed thermal power, with a minimum limit of 100cm²;
- be made in such a way that the vent openings, both on the inside and outside of the wall, cannot be obstructed;
- be protected with grills or similar systems that do not reduce the opening section indicated above;
- be situated at a height near-floor level and they must not obstruct the correct operation of the combustion product discharge devices; if this position is not possible, the section of the ventilation openings must be enlarged by at least 50%.

VENTILATION FROM ADJOINING ROOMS

The air flow can also be obtained from an adjoining room as long as:

- the adjoining room is equipped with direct ventilation in compliance with the paragraphs described above;
- the adjoining room is not used as a bedroom or a common area of the building;
- the adjacent room is not a room with a fire hazard, such as storage sheds, garages, combustible material store rooms, etc...;
- the adjoining room does not become a vacuum compared to the room to be ventilated due to a reverse draught effect (the reverse draught can be caused by the presence in the room of either another heating appliance running on any type of fuel, a fireplace, or any suction device, which have not been provided with an air intake);
- the air flow from the adjoining room to the room to be ventilated is unobstructed through the permanent apertures having an overall net section of no less than that indicated above. These apertures can be obtained by enlarging the space between the door and the floor.

SINGLE OR MULTIPLE VENTILATION DUCTING

If the combustion air is supplied through pipes, the available draught, produced by the installed appliance in use and by the corresponding combustion product evacuation system, must be greater than the sum of the resistance offered by the pipes (frictional resistance, resistance due to direction changes, cross-sectional restrictions, etc...).

The single ventilation pipes can be vertically and horizontally oriented: the length of the horizontal sections must be reduced to a minimum.

The connectors between pipes with different orientations must not have any reduced cross-sections with sharp bends.

The angle of connection between the axes of two successive pipes must not be less than 90°.

For combustion air supplied through branched pipes, the sum of the resistance offered by the pipes (frictional resistance, resistance due to direction changes, cross-sectional restrictions, etc....) can be a maximum of 10% of the available draught, produced by the various appliances in use installed on the various floors and by the combustion product evacuation system.

The branched ventilation pipes must be vertically-oriented with an uphill run.

The inlet vent to the room to be ventilated must be located down low and in a position where it does not interfere with the discharge of combustion products and must be protected by a grill or similar device.

LAMBDA S29 – S35 – S46 EVO5

11 – ELECTRICAL WIRING

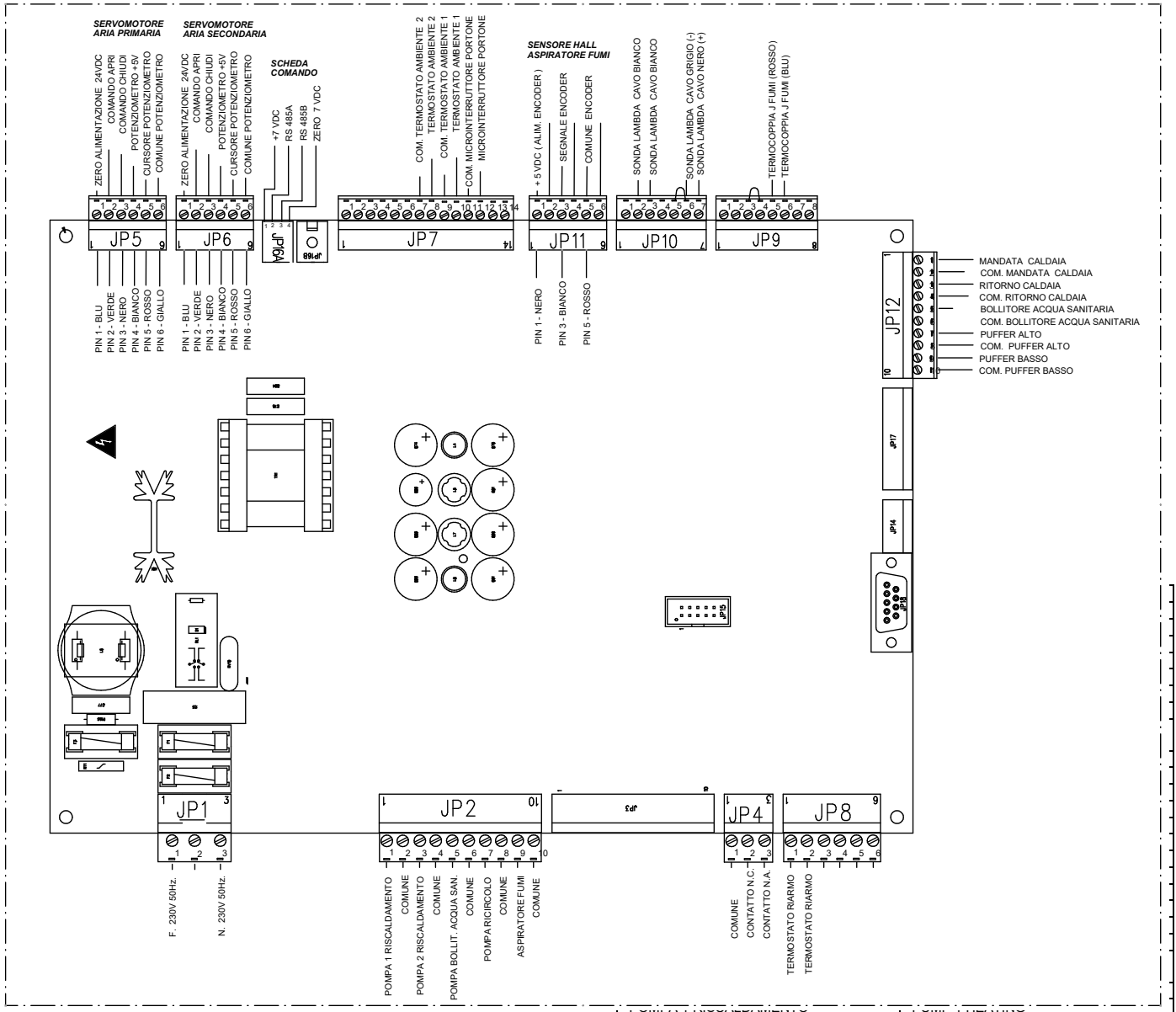

Legenda schema elettrico	Electrical wiring key
TERMOCOPIA J FUMI (BLU)	THERMOCOUPLE J SMOKE (BLUE)
TERMOCOPIA J FUMI (ROSSO)	THERMOCOUPLE J SMOKE (RED)
SONDA LAMBDA CAVO NERO (+)	SENSOR LAMBDA CABLE BLACK (+)
SONDA LAMBDA CAVO GRIGIO (-)	SENSOR LAMBDA CABLE GREY (-)
SONDA LAMBDA CAVO BIANCO	SENSOR LAMBDA CABLE WHITE
BLU	BLUE
VERDE	GREEN
NERO	BLACK
BIANCO	WHITE
ROSSO	RED
GIALLO	YELLOW
SENSORE HALL	HALL SENSOR
ASPIRATORE FUMI	SMOKE SUCTION UNIT
COMUNE ENCODER	COMMON ENCODER
SEGNALE ENCODER	ENCODER SIGNAL
+5VDC (ALIM. ENCODER)	+5VDC (ENCODER POWER SUPP.)
MICROINTERRUTTORE PORTONE	DOOR MICROSWITCH
COM. MICROINTERRUTTORE PORTONE	COMM. DOOR MICROSWITCH
TERMOSTATO AMBIENTE 1	ROOM TEMPERATURE THERMOSTAT 1
COM. TERMOSTATO AMBIENTE 1	COMM. ROOM TEMPERATURE THERMOSTAT 1
TERMOSTATO AMBIENTE 2	ROOM TEMPERATURE THERMOSTAT 2
COM. TERMOSTATO AMBIENTE 2	COMM. ROOM TEMPERATURE THERMOSTAT 2
SCHEDA COMANDO	CONTROL BOARD
ZERO 7VDC	ZERO 7VDC
SERVOMOTORE ARIA PRIMARIA	PRIMARY AIR SERVOMOTOR
SERVOMOTORE ARIA SECONDARIA	SECONDARY AIR SERVOMOTOR
COMUNE POTENZIOMETRO	COMMON POTENTIOMETER
CURSORE POTENZIOMETRO	POTENTIOMETER CURSOR
POTENZIOMETRO + 5V	POTENTIOMETER + 5V
COMANDO CHIUDI	COMMAND CLOSE

12 – TROUBLESHOOTING CAUSE - SOLUTION

PROBLEM	POSSIBLE CAUSE	SOLUTION
"DOOR OPEN" APPEARS ON THE DISPLAY	THE CASING DOOR IS OPEN	CLOSE THE DOOR
"ALARM THERMOSTAT RESET" APPEARS ON THE DISPLAY	THE RESET THERMOSTAT TRIPPED	THE POWER SUPPLY MAY HAVE FAILED FOR A PROLONGED PERIOD OF TIME
		CARRY OUT LOWER LOADS OF WOOD COMPLIANT WITH THE SYSTEM ABSORPTION
"SMOKE EXTRACTOR ENCODER ALARM" APPEARS ON THE DISPLAY	THE ENCODER OF THE SMOKE EXTRACTOR DETECTS A ROTATION VALUE OF THE SMOKE SUCTION UNIT THAT IS TOO LOW	CONTACT THE SERVICE CENTRE
"CONTROL ELECTRONICS ALARM" APPEARS ON THE DISPLAY	FAULTS HAVE BEEN DETECTED ON THE MOTORISED AIR ACTUATORS	CONTACT THE SERVICE CENTRE
"LAMBDA SENSOR ALARM" APPEARS ON THE DISPLAY	A FAULT HAS BEEN DETECTED ON THE LAMBDA SENSOR	CONTACT THE SERVICE CENTRE
"TEMPERATURE SENSOR ALARM" APPEARS ON THE DISPLAY	A FAULT HAS BEEN DETECTED ON A TEMPERATURE SENSOR	CONTACT THE SERVICE CENTRE
"LIGHTING FAILURE REPEAT PROCEDURE" APPEARS ON THE DISPLAY	THE SMOKE DOES NOT REACH 100° C IN 50 MINUTES, THE BURNER IS BLOCKED	CLEAN THE BURNER
	THE SMOKE DOES NOT REACH 100° C IN 50 MINUTES, HIGH MOISTURE CONTENT IN WOOD OR LOGS ARE TOO THICK	USE DRY, SMALLER LOGS
	THE SMOKE DOES NOT REACH 100° C IN 50 MINUTES, NO AIR IN THE ENVIRONMENT	CREATE A SUITABLE OPENING FOR THE COMBUSTION AIR IN COMPLIANCE WITH THE INDICATIONS IN PARA. 7
"TEMP. H2O < 45°C FOR 15 MIN" APPEARS ON THE DISPLAY	THE RETURN TEMPERATURE DROPPED FOR 15 MINUTES BELOW 45°C DURING OPERATION	THERE MUST NOT BE NATURAL CIRCULATION
		VERIFY THAT THE RECIRCULATING PUMPS ARE CONNECTED TO THE BOILER
		VERIFY THAT THE MOTORISED MIXING UNIT OR THE MIXING VALVE HAVE BEEN ASSEMBLED
"GENERAL CLEAN ALARM" APPEARS ON THE DISPLAY	APPEARS AFTER THE BOILER HAS REACHED 30 WORK HOURS	CLEAN THE BOILER
"COMMUNICATION INTERRUPTION" APPEARS ON THE DISPLAY	THE CABLE CONNECTING THE POWER BOARD TO THE CONTROL BOARD IS DAMAGED	CONTACT THE SERVICE CENTRE
THE SMOKE TEMPERATURE DOES NOT INCREASE	BOILER DIRTY, TUBE BUNDLE DIRTY	CLEAN THE BOILER/TUBE BUNDLE FOLLOW THE INSTRUCTIONS IN PARA. 6
	LOGS NOT LOADED CORRECTLY	LOAD THE BOILER CORRECTLY AS DESCRIBED IN PARAGRAPH 5
	BED OF EMBERS TOO HIGH	REMOVE THE EMBERS AND RELOAD WITH A BED OF EMBERS OF MAXIMUM 5 CM.
THE TEMPERATURE OF THE BOILER IS NOT RISING	BOILER VERY DIRTY	CLEAN THE BOILER AS DESCRIBED IN PARAGRAPH 6
	IF FITTED WITH A CLOSED EXPANSION TANK, THE THERMAL RELIEF VALVE IS LEAKING WATER OR NOT PERFECTLY CLOSED	CHECK AND REPLACE THE VALVE IF NECESSARY
	ASH PAN NOT ENTIRELY PUSHED BACK	PLACE THE DRAWER CORRECTLY
"FUEL FINISHED EXECUTE CLEANING" APPEARS ON THE DISPLAY	THE FUEL INSIDE THE COMBUSTION CHAMBER OF THE BOILER HAS FINISHED	LOAD THE BOILER TO CONTINUE WITH A NEW WORK CYCLE

13 – CONDITIONS OF WARRANTY

POINT 1A

Every Thermorossi product is delivered with this warranty certificate. This warranty is to be considered a **conventional guarantee** as defined in art. 133 of Italian Legislative Decree no. 206 dated 6 September 2005 (so-called Consumer Code). This warranty does not in any way affect the rights expressly granted to the consumer concerning the sale of consumer goods as set forth in Italian Legislative Decree no. 206/2005. The consumer is therefore always entitled to exercise these rights with the seller, under the terms and conditions established by the aforementioned legislative decree and by this conventional guarantee.

This warranty is valid only in the case where the product is purchased for domestic uses (i.e. the subject is a consumer as defined in art. 3 paragraph 1, point A of Italian legislative decree 206/2005) and, in any case, not for business or professional purposes. Barring the cases provided for by law, it is the responsibility of the purchaser to demonstrate any product defects and should such product be found to be fully functional, the warranty will be considered inapplicable. The warranty is valid only if the product is installed, used and serviced in accordance with all the instructions provided in the use, maintenance and installation guide delivered with the product.

This warranty certificate is valid solely for the parts mentioned herein.

The warranty is valid for 24 months for the product, excluding the components expressly indicated in point 1C herein. Thermorossi is therefore not responsible for demonstrating the full functionality of the system to which the product is connected, which remains the customer's responsibility. The warranty is subject to the limits and exclusions specified in this warranty certificate and exclusively under the conditions stated herein. In any case, for a warranty claim to be taken into consideration, the customer must report the non-conformity to the seller in writing no later than two months from the date of its identification. The warranty is null and void if this deadline is not respected. The purchaser is responsible for demonstrating that this warranty is valid; this can be done by presenting a delivery document issued by the seller or another document (receipt, till receipt or similar...) indicating the name of the seller, the product identification details (e.g. model code) and the date of the sale or delivery date if later.

Therefore, for the warranty to be valid, the above documentation must be kept by the consumer and shown when the product is being inspected/repaired. This warranty is valid solely under the following conditions:

- all product installation or connection operations are carried out by personnel qualified in accordance with law, who must issue an appropriate declaration of conformity attesting that the work has been carried out according to best practices and scrupulously following the instructions provided in the use, maintenance and installation guide delivered with the product and the regulations regarding systems and safety.
- all operations involving the use of the product, as well as periodic maintenance, must be carried out according to the instructions and indications provided in the use, maintenance and installation guide delivered with the product.
- all repairs to the product must be carried out by personnel of Thermorossi S.p.A. authorised service centres;
- only original Thermorossi spare parts, accessories and consumables must be used.

The warranty (**if present**) on the **vitrified body** lasts **8 years** from the invoice date.

The warranty (**if present**) on the **standard wet body** lasts **4 years** from the invoice date.

Both the warranty on the vitrified body and that on the standard wet body, if present, only cover the internal surface of the combustion chamber in contact with combustion gases, notwithstanding the limits and exclusions listed in this warranty certificate and exclusively in the conditions hereby reported. It shall not apply if the product was not installed by a qualified technician who has verified that all characteristics of the system are suitable. Such characteristics must comply with the legislation on safety and systems. It shall not apply if the product is connected to a system that may cause corrosion, deposits or breakage due to stray currents, condensation, water aggressiveness or acidity, improper descaling treatments, lack of water, sludge or limescale deposits. Failing to connect the system circulating pump to the specific terminal block in the generator causes the warranty to be immediately declared null and void. The system must necessarily guarantee a return water temperature exceeding 55°C.

POINT 1B

Components damaged by causes and/or events external to the product are excluded from this warranty.

The warranty does not apply to damage caused by: excessive or insufficient flue outlet draught, lack of maintenance, failure to clean the product, atmospheric and chemical agents, corrosion of any type and/or nature, fuel overloads, fire, cleaning, tampering with the product, parts damaged due to overheating caused by a lack of maintenance or excess fuel load.

POINT 1C

The following components are excluded from the warranty: door ceramic glass, majolica tile parts, refractory materials, painted or galvanised parts, enamelled parts, gaskets, knobs, handles, thermometers and consumables in general. Warranty replacement does not imply any resetting of the conventional guarantee or its extension. Colour variations on the majolica tiles and the presence of crazing or spotting are not a reason for claims because they are natural characteristics of the materials themselves. Parts found to be defective due to negligence or careless use, damage during transport, incorrect maintenance, or incorrect installation, are not covered by the warranty.

POINT 2A

The technical assistance centre will take appropriate action as soon as possible in the event of failure of the product to function. In this regard, no compensation shall be due for damage or problems following forced inactivity of the product. Repairs or replacements carried out under this conventional guarantee do not imply any resetting of the conventional guarantee or its extension. Thermorossi will repair the product if possible and this is not too costly for the company. The product will only be replaced if it is objectively impossible to repair it and its replacement is not too costly. The product will not be replaced if external factors have caused evident malfunctions. For the purposes of this conventional guarantee, replacement of the product shall be considered too costly if it entails unreasonable expenses compared to its repair, taking into account the estimated value of the product without the defect, the seriousness of the non-conformity and the possibility of repairs being carried out without significantly inconveniencing the consumer.

LAMBDA S29 – S35 – S46 EVO5

If technical assistance is provided by the personnel of the technical assistance centres at the customer's request, and such assistance is provided outside the warranty (e.g. because the warranty is not valid, because the customer has not sent the warranty certificate in the set times, or because the part is excluded from this warranty), the costs of such assistance will be charged in full to the customer. These costs include:

Call-out fee, the cost of labour and any parts to be replaced. These costs will be of a reasonable amount and the customer can ask the assistance centre for an indication of the amounts in advance. In any case, it should be noted that requests for assistance "under warranty" which, based on the report and analysis carried out by the assistance centre, are the result of tampering, negligence or non-compliant installation, lack of cleaning or in any case not falling within the scope of this conventional guarantee, will entail:

Call-out fee, the cost of labour and any parts to be replaced. These costs will be of a reasonable amount and the customer can ask the assistance centre for an indication of the amounts in advance.

POINT 2B

Thermorossi S.p.A. declines liability for any damage directly or indirectly caused to persons, animals or property, due to or related to installation that does not comply in full with current regulations and/or installation, use and maintenance that does not comply in full with all the instructions contained in the installation, use and maintenance guide delivered with the product.



THERMOROSSI 

Fire Lovers

THERMOROSSI S.p.A.

Via Grumolo, 4 (Z.I.) 36011 Arsiero (VI) - ITALY

Fax 0445.741657 - www.thermorossi.com - info@thermorossi.it