

THERMOROSSI

Fire Lovers

- *Pellet Home Collection* -



THERMOROSSI
Fire Lovers

- Pellet Home Collection -



Since 1968 To present

- ITA Sorta in una provincia ricca di tradizione metalmeccanica e aperta alle più innovative tecnologie, Thermorossi opera con successo da oltre 55 anni nel settore del riscaldamento fino a diventare, oggi, una tra le più affermate ed avanzate industrie europee nella produzione di caminetti, stufe, termocucine e caldaie.
- FRA Installé depuis plus de 55 ans dans une région riche en tradition mécanique et métallurgique ouverte aux technologies les plus avancées, Thermorossi est un des leaders européens dans la production de cheminées, poêles, inserts, thermo-cuisinières et chaudières, à bûches et à granulés.
- ENG Established in a province renowned for its metalworking traditions and open to modern technology, Thermorossi has been working with success in the heating sector for 55 years and is now one of the leading and advanced European companies in the production of fireplaces, stoves, central heating cookers and boilers.
- DEU Seit 55 Jahren arbeitet Thermorossi in der Heizungsbranche mit Erfolg und zählt heute als einer der namhaftesten und innovativsten Hersteller von Kaminen, Kaminöfen, Zentralheizungskochherden und Heizkesseln in Europa.
- ESP Establecida en una provincia renombrada por su tradición metalúrgica y abierta a las tecnologías más modernas, Thermorossi trabaja con éxito en el sector de la calefacción desde hace 55 años y ahora es una de las empresas europeas principales y más avanzadas en la producción de chimeneas, estufas, cocinas de calefacción central y calderas de leña.

Sustainable

DEVELOPMENT

- ITA Un sogno d'inverno è riscaldarsi con soluzioni energetiche rinnovabili, perché possiamo contribuire alla riduzione delle emissioni di gas serra e ad un migliore utilizzo dell'energia, perché siamo un'azienda che crede nello sviluppo sostenibile, che possa essere compatibile con la salvaguardia dell'ambiente per le generazioni future.
- FRA Le rêve en hiver c'est de se chauffer avec des solutions d'énergies renouvelables, car ainsi nous pouvons contribuer à la réduction des émissions de gaz à effet de serre et à une meilleure utilisation de l'énergie, parce que notre entreprise croit au développement durable, qui puisse être compatible avec la protection de l'environnement pour les générations futures.
- ENG A dream in winter: to warm up with renewable energy solutions, because we can contribute to the reduction of greenhouse gas emissions and to a better use of energy, because our company believes in a sustainable development compatible with the protection of the environment for future generations.
- DEU Ein Wintertraum ist es, sich mit erneuerbaren Energielösungen aufzuwärmen, denn wir können zur Reduzierung der Treibhausgasemissionen und zu einer besseren Energienutzung beitragen, denn wir sind ein Unternehmen, das an eine nachhaltige Entwicklung glaubt, die mit dem Schutz der Umwelt für zukünftige Generationen vereinbar ist.
- ESP Un sueño invernal es calentarse con soluciones de energías renovables, porque podemos contribuir a la reducción de las emisiones de gases de efecto invernadero y a un mejor uso de la energía, porque nuestra empresa cree en un desarrollo sostenible que puede ser compatible con la protección del medio ambiente para las generaciones futuras.





Ogni apparecchio viene acceso in fabbrica e verificato per almeno 1 ora di funzionamento.

Chaque appareil est allumé en usine et contrôlé pendant au moins 1 heure de fonctionnement.

Every unit is tested for 1 hour in the factory.

Jeder Ofen wurde schon im Werk eine Stunde beheizt und eingestellt.

Cada equipo se ha probado y testado en fábrica durante una hora.

I nostri prodotti non necessitano di ulteriori costi per tarature e collaudi. Nel caso il pellet ENplus fosse di qualità diversa esistono diversi programmi di funzionamento selezionabili.

Nos produits ne nécessitent d'aucuns coûts de tarage ou d'essais. Au cas où les granulés soient de qualité différente de Enplus, nos produits disposent de divers programmes de fonctionnement.

Our products don't incur additional costs for adjustments or testing. In case of pellet fuel of lower quality than Enplus standards, it is possible to select different operation programs and set up.

Unsere Produkte müssen nicht nach der Installation speziell eingestellt und kontrolliert werden, denn, wenn die Pelletqualität variiert, kann das System per Tastendruck darauf einfach und simpel angepasst werden.

Nuestros productos no necesitan de más costes por ajustes o pruebas. En el caso que el combustible sea de calidad distinta a ENplus existen programas de operación opcionales.

Il grande cassetto cenere e le adeguate ispezioni per la pulizia semplificano la manutenzione mantenendo l'efficienza ai massimi livelli.

Le grand tiroir des cendres et les inspections de nettoyage pratiques simplifient l'entretien, gardant le rendement au plus haut niveau. Aucune surprise durant l'entretien périodique.

The wide ash pan and the obvious inspection points make maintenance easier keeping the efficiency at highest levels. Simple periodic maintenance.

Der große Ascheauffang sowie die leicht zugänglichen Reinigungsöffnungen machen die Reinigung des Gerätes viel einfacher und komfortabler, wodurch die Effizienz des Gerätes hoch gehalten wird.

El ancho cajón de ceniza y una inspección de limpieza cómoda simplifican la mantención manteniendo el rendimiento a máximos niveles y evitando sorpresas.

Il fascio tubiero verticale e l'elevato numero di elementi formano il sistema ThermoCore®.

Le faisceau tubulaire vertical et ses nombreux éléments forment le système ThermoCore®, qui augmente la superficie d'échange de chaleur et améliore le rendement thermique.

The vertical pipes heat exchanger and the high number of exchange elements form the ThermoCore® system. This system increases the exchange surface and improve thermal efficiency.

Der vertikale Rohrwärmetauscher mit großer Wärmetauscherfläche ist das Herzstück des ThermoCore® Systems. Dieses System steigert die Wärmetauscherfläche und erhöht den Wirkungsgrad.

El intercambiador turbolador vertical de muchos elementos crea el sistema ThermoCore®. Este sistema aumenta la superficie de intercambio y mejora el rendimiento térmico.

Il ventilatore ambiente, con motore esterno, è garantito 4 anni perché ermetico alla polvere.

Le ventilateur d'air ambiant, avec son moteur à rotor externe, est garanti 4 ans parce qu'hermétique à la poussière.

External rotor room fan is guaranteed for 4 years being hermetic to dust.

4 Jahre Garantie auf den hermetisch dichten Raumluftventilator.

El ventilador ambiente con motor rotor externo lleva 4 años de garantía al ser hermetico al polvo.

Funzione «Chrono» per programmazione settimanale (tre accensioni e tre spegnimenti al giorno).

Fonction « Chrono » pour la programmation hebdomadaire (trois allumages et trois extinctions par jour).

«Chrono» function for weekly timing program (three daily Starts).

Funktion «Chrono» für wöchentliche Programmierung (drei Ein-Ausschaltung Pro Tag).

Función «Chrono» para la programación semanal (tres ciclos de encendido y apagado para cada día).

Rigidi criteri costruttivi, elevati spessori della materia prima impiegata, offrono un grande accumulo termico e durata dei componenti.

Les critères de construction rigides, et les grosses épaisseurs des matériaux utilisés, offrent une grande capacité d'accumulation thermique, de stabilité dimensionnelle du brûleur, et de durée des composants.

The strict manufacturing standards, the high quality of raw materials, grant higher heat accumulation, stable durability of the burning pot and other components.

Hohe Produktionsstandards, hohe Qualität der Rohstoffe, garantieren lange Lebensdauer aller feuerberührten Teile und des Brenners.

Nuestros equipos son el resultado de exigentes criterios de construcción. Ofrecemos equipos con una gran acumulación térmica, estabilidad dimensional del quemador y durabilidad de los componentes.

I nostri prodotti a regime minimo misurano solo 36 decibel di fruscio durante il funzionamento.

Au régime minimum de fonctionnement, nos produits émettent seulement 36 décibels de bruissement.

Our products produce only 36 decibels of noise at minimum level of operation.

Unsere Produkte emittieren nur 36 Dezibel bei kleinster Heizleistung.

Nuestros equipos trabajan a niveles mínimos de sonido. Solamente miden 36 decibelios de sonoridad a nivel mínimo de operación.

Ogni stufa è dotata di componenti meccanici che garantiscono una maggiore sicurezza dell'apparecchio, come ad esempio una valvola di sovrappressione e un pressostato.

Chaque poêle est doté de composants mécaniques qui garantissent une plus grande sécurité comme, entre autres, la soupape de surpression et le pressostat.

Every stove is equipped with mechanical safety devices that assure an added safety, such as over-pressure valve and pressure switch.

Ausgestattet mit mechanische Sicherheitseinrichtungen wie zum Beispiel Entlüftungsventil und Druckreduzierventil.

Cada estufa es equipada con componentes mecánicos que garantizan la seguridad del equipo, como por ejemplo la valvula de sobrepresión y el presostato.

È possibile regolare il livello di ventilazione al minimo e la potenza di combustione al massimo.

Les niveaux de ventilation et de puissance de combustion sont indépendants : il est possible de réguler le niveau de ventilation au minimum et la puissance de combustion au maximum, pour bien se chauffer dans le plus grand silence.

Ventilation and output power set up levels are independent: it is possible to set the ventilation at minimum and output power at maximum.

Heizleistung sowie Gebläseleistung sind unterschiedlich einstellbar. Es ist möglich, bei höchster Heizleistung trotzdem die kleinste und leiseste Gebläseleistung zu wählen.

Los niveles de ventilación y potencia son independientes. Esto permite poner el nivel de ventilación al mínimo y la potencia de combustión al máximo.

La web-app, assieme al modulo wi-fi (optional), consente di gestire comodamente la tua stufa tramite smartphone, tablet e desktop.

La web-app, associée au module wi-fi (en option), vous permet de gérer confortablement votre poêle via un smartphone, une tablette et un ordinateur de bureau.

The web-app, together with the Wi-Fi module (optional), allows you to conveniently manage your stove via smartphone, tablet and desktop.

Die Web-App, zusammen mit dem Wi-Fi-Modul (optional), ermöglicht Ihnen die komfortable Verwaltung Ihres Ofens über Smartphone, Tablet und Desktop.

La aplicación web, junto con el módulo wi-fi (opcional), le permite gestionar cómodamente su estufa a través del smartphone, la tableta y el ordenador.

Il pannello digitale LCD di nuovo design è implementato da messaggi grafici semplici ed intuitivi.

Le panneau digitale LCD au design entièrement nouveau propose des messages graphiques simples et intuitifs.

The new design of control panel has been updated with simple visual messages.

Das neue Bedienfeld wurde mit verschiedenen einfachen Symbolen und Mitteilungen ausgestattet.

La pantalla LCD de nueva generación ha sido actualizada utilizando mensajes gráficos sencillos e intuitivos.



Made in Italy: Thermorossi si avvale delle più moderne tecniche di produzione e tutti i prodotti sono conformi alle più severe normative europee.

Made in Italy: Thermorossi se sert des techniques de production les plus performantes et tous les produits sont conformes aux normes européennes les plus sévères.

Made in Italy: Thermorossi uses the most modern techniques of production and all products conform to the strictest European regulations.

Made in Italy: Thermorossi benutzt die neuesten Fertigungsmethoden und alle Geräte erfüllen die strengsten Anforderungen der Europäischen Richtlinien bezüglich Sicherheit und Umweltschutz.

Made in Italy: Thermorossi utiliza las técnicas más modernas de producción y todos los productos se ajustan a las más estrictas normas europeas.



Flusso d'aria calda orientabile.

Flux d'air chaud orientable.

Directable and adjustable air flow.

Unterschiedlich einstellbare Warmluftauslässe.

Flujo de aire orientable y direccionable.



Pratico e igienico piano scaldavivande di facile pulizia.

Chauffe-plats pratique et hygiénique, simple à nettoyer.

Incorporates practicality and hygiene, easy to clean hotplate heats food.

Hygienische, simpel zu reinigen, speiseaufwärmende Platte zum kochen ist vorhanden.

Práctico plano para calentar comidas higiénico y fácil de limpiar.

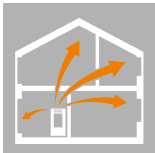

Capace di distribuire il calore in più ambienti e riscaldare più locali anche su piani diversi.

Capable de distribuer la chaleur dans plusieurs pièces et de chauffer plusieurs locaux, même sur différents étages.

Capable of distributing heat to various rooms, even on different floors.

Kann Wärme auf mehrere Räume verteilen und mehrere Räumlichkeiten auf verschiedenen Stockwerken beheizen.

Capaz de distribuir el calor en varias habitaciones y calentar varios locales, aunque estén en pisos diferentes.



Briocatore brevettato PelletPower®.

Brûleur breveté PelletPower®.

PelletPower® patented burner.

Patentierter Brenner PelletPower®.

Quemador patentado PelletPower®.



Funzione Natural Air: puoi riscaldarti in assoluto silenzio disattivando il ventilatore e usufruire così del calore diffuso dalla convezione naturale.

Fonction Natural Air : vous pouvez vous chauffer dans un silence absolu, en arrêtant le ventilateur, et profiter ainsi de la chaleur diffusée par la convection naturelle.

Natural Air function: you can heat yourself in absolute silence by turning off the fan and take advantage of the heat diffused by natural convection.

Funktion Natural Air: Sie können sich in absoluter Stille erwärmen, indem Sie den Ventilator ausschalten und die durch natürliche Konvektion verbreitete Wärme nutzen.

Función Natural Air: puede calentarse en absoluto silencio, apagando el ventilador y aprovechando el calor difundido por convección natural.



La fiamma più piacevole perché meno aspirata e più ampia e naturale, la magia del fuoco in una "cornice" moderna e tecnologica.

La flamme la plus agréable car moins aspirée et plus ample et naturelle, la magie du feu dans un "cadre" moderne et technologique.

The most pleasant flame because it is less aspirated and more ample and natural, the magic of fire in a modern and technological "frame".

Die angenehmste Flamme, weil sie weniger angesaugt und mehr großzügig und natürlich ist, die Magie des Feuers in einem modernen und technologischen "Rahmen".

La llama más agradable porque es menos aspirada y más amplia y natural, la magia del fuego en un "marco" moderno y tecnológico.



Possibilità di installare la stufa affinché prelevi aria primaria per la combustione dall'esterno, limitando il consumo di ossigeno nei locali.

Possibilité de prélever directement l'air primaire de combustion depuis l'extérieur, pour limiter la consommation d'oxygène dans les locaux.

Option to take combustion primary air from outside, in order to avoid oxygen consumption in the room.

Option, um Verbrennung-Primärluft von aussen zu nehmen, um Sauerstoffverbrauch im Raum zu vermeiden.

Posibilidad de tomar aire primario de combustión desde el exterior, limitando el consumo de oxígeno en las habitaciones.



Uscita fumi superiore con tubo semplice o coassiale.

Sortie de fumée sur le dessus avec tuyau simple ou coaxial.

Upper smoke outlet single-tube or coaxial.

Oberer Rauchabzug einrohrig oder koaxial.

Salida de humos superior monotubo o coaxial.



Input aria primaria da esterno.

Entrée d'air primaire externe.

External primary air input.

Zuluftanschluss der externen Verbrennungszuluft.

Entrada externa de aire primario.



Sistema di filtraggio della polvere facilmente ispezionabile e lavabile.

Le filtre s'inspecte et se lave facilement.

The filter is easy to check and clean.

Der Filter ist einfach zu reinigen.

Sistema de filtración del aire de calefacción con filtro que se puede.



Grazie ad un accurato studio di progettazione ingegneristica è possibile intercambiare più rivestimenti con diverse modalità di riscaldamento (aria, convezione naturale, acqua). Scegli la tua tecnologia e cambia lo stile come e quando vuoi tu.

Grâce à une étude de conception technique précise, il est possible d'interchanger plusieurs revêtements avec différents modes de chauffage (air, convection naturelle, eau). Choisissez votre technologie et changez le style comme et quand vous le souhaitez.

Thanks to an accurate engineering design study it is possible to interchange several claddings with different heating modes (air, natural convection, water). Choose your technology and change the style as and when you want.

Dank einer genauen Konstruktionsstudie ist es möglich, mehrere Verkleidungen mit verschiedenen Heizarten (Luft, natürliche Konvektion, Wasser) auszutauschen. Wählen Sie Ihre Technologie und ändern Sie den Stil wie und wann Sie wollen.

Gracias a un preciso estudio de diseño de ingeniería es posible intercambiar varios revestimientos con diferentes modos de calefacción (aire, convección natural, agua). Elige tu tecnología y cambia el estilo como y cuando quieras.

Thermorossi - I perché di una scelta

Pourquoi Thermorossi ? - Why to choose Thermorossi? - Die Gründe einer Wahl - Los motivos de una elección



Emotional Flame

**Alcuni vedono una fiamma emozionale
Noi una nuova era di stufe a pellet**



Emotional Flame

La magia del fuoco in una “cornice” moderna e tecnologica

La magie du feu dans un « cadre » moderne et technologique

The magic of fire in a modern and technological “frame”

Die Magie des Feuers in einem modernen und technologischen “Rahmen”

La magia del fuego en un “marco” moderno y tecnológico

Setting and reaching a

beautiful flame

ITA La fiamma ancora più bella. Grazie al nuovo bruciatore PelletPower® a letto di braci con spargimento orizzontale e movimento dinamico e progressivo, la visione del fuoco è ancora più bella ed emozionante. Una fiamma più piacevole perché meno aspirata e più ampia e naturale, la magia del fuoco in una “cornice” moderna e tecnologica con minime emissioni ed elevate prestazioni.

FRA La flamme est encore plus belle. Grâce au nouveau brûleur à lit de braises à étalement horizontal et à mouvement dynamique et progressif, la vision du feu est encore plus belle et excitante. Une flamme plus agréable parce qu'elle est moins aspirée et plus large et plus naturelle, la magie du feu dans un « cadre » moderne et technologique avec des émissions minimales et des performances élevées.

ENG The flame even more beautiful. Thanks to the new PelletPower® bed of embers burner with horizontal spreading and dynamic and progressive movement, the vision of the fire is even more beautiful and exciting. A more pleasant flame because it is less drawn in and wider and more natural, the magic of fire in a modern and technological “frame” with minimum emissions and high performance.

DEU Die Flamme noch schöner. Dank des neuen Glutbettbrenners PelletPower® mit horizontaler Ausbreitung und dynamischer und progressiver Bewegung wird die Vision des Feuers noch schöner und aufregender. Eine angenehmere Flamme, weil sie weniger eingezogen und breiter und natürlicher ist, die Magie des Feuers in einem modernen und technologischen “Rahmen” mit minimalen Emissionen und hoher Leistung.

ESP La llama es aún más hermosa. Gracias al nuevo lecho de brasas PelletPower® con propagación horizontal y movimiento dinámico y progresivo, la visión del fuego es aún más bella y emocionante. Una llama más agradable porque es menos atraída y más amplia y natural, la magia del fuego en un “marco” moderno y tecnológico con mínimas emisiones y alto rendimiento.



PELLETPOWER®

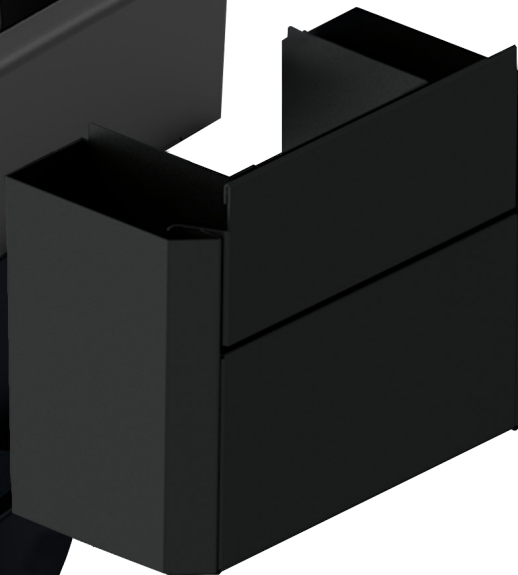
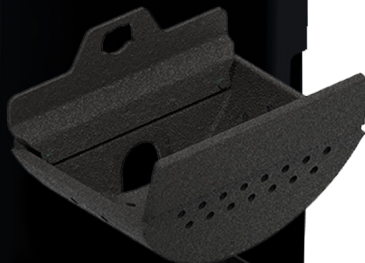

Nuovo bruciatore brevettato che fa la differenza

Un nouveau brûleur breveté qui fait la différence

New patented burner that makes the difference

Ein neuer patentierter Brenner, der den Unterschied macht

Un nuevo quemador patentado que marca la diferencia

(Patent pending n° 102019000025156)

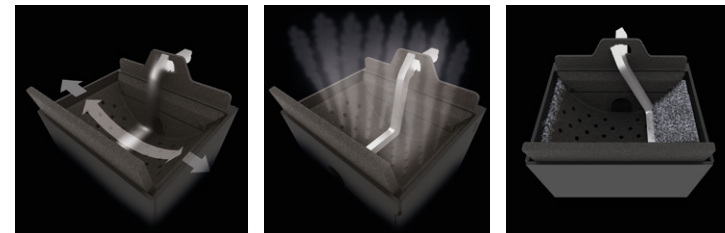

Advanced cleaning

PELLETPOWER®

- ITA** La nuova tecnica di costruzione, più precisa ed affinata, garantisce sicurezza ed emissioni sotto controllo. Con Pelletpower le ceneri vengono rimosse ai lati e raccolte nel cassetto, il bruciatore assicura rendimenti costanti senza interruzioni e nessun spreco di combustibile. Ancora più evoluto e industrializzato grazie alla tecnologia Advanced Cleaning, costruito in lega Incoloy 800HT super resistente, ispezionabile ed estraibile dall'utilizzatore.
- FRA** La nouvelle technique de construction, plus précise et plus raffinée, garantit la sécurité et des émissions sous contrôle. Avec PelletPower®, les cendres sont enlevées sur les côtés et collectées dans le tiroir, le brûleur assure un rendement constant sans interruption et sans gaspillage de combustible. Encore plus avancé et industrialisé grâce à la technologie « Advanced Cleaning », construite en alliage Alloy 800HT super résistant, qui peut être inspecté et retiré par l'utilisateur.
- ENG** The new, more precise and refined construction technique guarantees safety and emissions under control. With Pelletpower the ashes are removed at the sides and collected in the drawer, the burner ensures constant efficiency without interruption and no waste of fuel. Even more advanced and industrialized thanks to the Advanced Cleaning technology, built in super resistant Incoloy 800HT alloy, which can be inspected and removed by the user.
- DEU** Die neue, präzisere und verfeinerte Konstruktionstechnik garantiert Sicherheit und kontrollierte Emissionen. Bei Pelletpower wird die Asche seitlich entfernt und in der Schublade gesammelt, der Brenner sorgt für einen konstanten Wirkungsgrad ohne Unterbrechung und ohne Brennstoffverschwendung. Noch fortschrittlicher und industrialisierter dank der fortschrittlichen Reinigungstechnologie, die aus einer superbeständigen Incoloy 800HT-Legierung besteht und vom Benutzer inspiziert und entfernt werden kann.
- ESP** La nueva técnica de construcción, más precisa y refinada, garantiza la seguridad y las emisiones bajo control. Con la energía de los pellets las cenizas se retiran a los lados y se recogen en el cajón, el quemador asegura una eficiencia constante sin interrupciones y sin desperdicio de combustible. Aún más avanzada e industrializada gracias a la tecnología de limpieza avanzada, construida en una aleación Incoloy 800HT súper resistente, que puede ser inspeccionada y eliminada por el usuario.

- «**Rendimento superiore al 90%** ottenuti grazie al bruciatore brevettato che sviluppa 2 fronti di fiamma in grado di cedere il calore sia agli scambiatori centrali che laterali normalmente inutilizzati nella combustione a pellet.»
- «**Rendements supérieurs à 90%** obtenus grâce au brûleur breveté qui développe 2 fronts de flamme en mesure de céder la chaleur aussi bien aux échangeurs centraux que latéraux, normalement inutilisés dans la combustion de granulés de bois.»
- «**Over 90% efficiency** is achieved thanks to the patented burner which develops 2 flame fronts capable of not only transmitting heat to the central heat exchangers but also to the ones on the side which are normally unused in pellet combustion.»

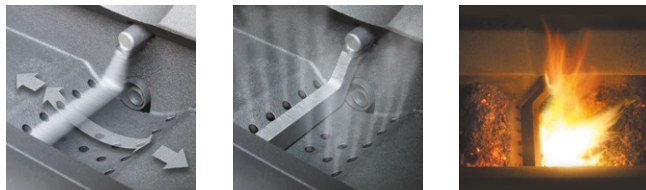
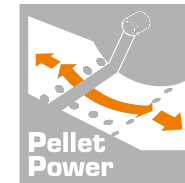

Up to
500 hours
NO-STOP

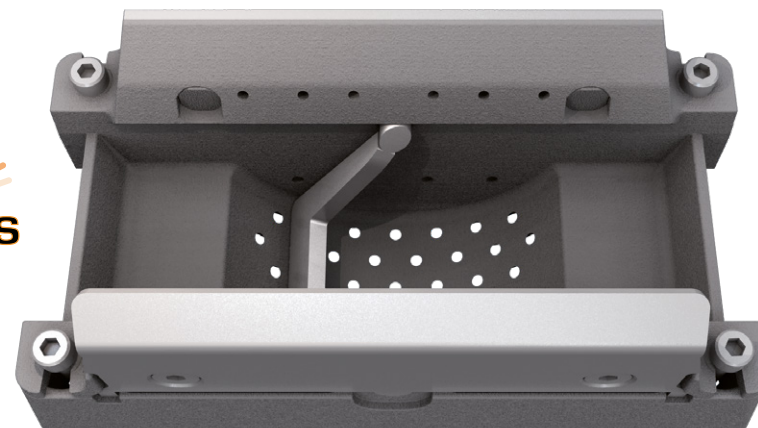

- **Rendimento costante senza interruzioni e nessun spreco di pellet**
Rendements performances constantes et sans interruption
Constant performance without interruption and no pellet waste
Konstante Leistung ohne Unterbrechungen und Pelletverschwendung
Rendimiento constante sin interrupciones y sin desperdicio de pellets
- **Candeletta resistente a basso consumo energetico, kW risparmiati in bolletta**
Résistance d'allumage durable à basse consommation d'énergie : kW économisés sur les factures d'énergie
Resilient spark plug with low energy consumption: kW saved in the bill
Die haltbare, energieeffiziente Zündkerze macht sich durch weniger kW in der Stromrechnung bemerkbar
Bugia de encendido con bajo consume energético, ahorro de kW en la factura de la luz
- **Super resistente in lega Incoloy 800 HT**
Alliage super résistant Incoloy 800 HT
Super durable Incoloy 800 HT alloy
Sehr widerstandsfähig in der Legierung Incoloy 800 HT
Sistema con palanca de limpieza en aleación Incoloy 800 HT, muy duradera
- **Manutenzione «FAI DA TE» semplificata, braciere scomponibile e ispezionabile**
Entretien simplifié à faire soi-même, brûleur démontable
Simplified "do-it-yourself" maintenance, decomposable and inspectable brazier
Vereinfachte, selbst durchzuführende Wartung, zerlegbarer und inspizierbarer Brenntopf
Automantenimiento simplificado, con brazero desmontable e inspeccionable
- **Nessuno spegnimento e riaccensione forzata**
Pas d'arrêts et de rallumages forcés
No forced shutdown and re-ignition
Kein forciertes Abschalten und erneutes Zünden
Sin apagado y reencendido forzado
- **Nessuna condensa, garantisce temperature fumi in sicurezza**
Pas de condensation, le brûleur garantit des températures de fumées sécurisées
No condensation, ensures safe flue gas temperatures
Kein Kondensat. Sichere Rauchgastemperaturen sind gewährleistet
Sin condensación, garantiza temperaturas seguras de los gases de combustión

PELLETPOWER®

- ITA I residui della combustione vengono rimossi dal dispositivo automatico mantenendo liberi i fori di passaggio dell'aria al bruciatore. Rendimento di combustione superiore rispetto ai bruciatori tradizionali a vaschetta, PELLETPOWER® garantisce il giusto apporto di ossigeno mantenendo costante il rendimento di combustione per lunghi tempi di funzionamento.
- FRA Les résidus de combustion sont balayés par le dispositif automatique, gardant les orifices de passage d'air du brûleur toujours libres. Rendement de combustion supérieur par rapport aux brûleurs traditionnels en forme de cuvette. Le PELLETPOWER® garantit le juste apport d'oxygène, maintenant le rendement de combustion constant, même en cas de fonctionnement prolongé.
- ENG Residues of burning are removed by the automatic system keeping the holes which take air to the burner completely free. Higher burning efficiency compared to traditional pan burners PELLETPOWER® maintains the correct rate of oxygen keeping the efficiency of combustion stable for longer periods of operation.
- DEU Der Brenner wird automatisch von den Verbrennungsrückständen befreit und somit bleiben die Luftöffnungen permanent sauber. Somit kann der Ofen permanent heizen und unnötiger Brennstoffverbrauch beim Startvorgang wird vermieden. Höherer Wirkungsgrad gegenüber herkömmlichen Systemen durch PELLETPOWER® erreicht der Ofen ein korrektes Sauerstoffverhältnis in der Verbrennung und hält den Wirkungsgrad der Verbrennung über lange Zeiten hoch.
- ESP Dispone de un sistema automático que despeja los residuos de combustión manteniendo los agujeros de paso de aire al quemador libres. El rendimiento de combustión es superior de los quemadores tradicionales a cubeta. PELLETPOWER®: Garantiza el correcto aporte de oxígeno manteniendo un rendimiento constante de combustión por largos tiempos de operación. La amortización de la máquina se realiza más rápidamente.

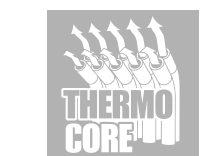

Scambiatore a fascio
tubiero THERMOCORE®
Échangeur de chaleur
à faisceau tubulaire
THERMOCORE®
pipe heat exchanger

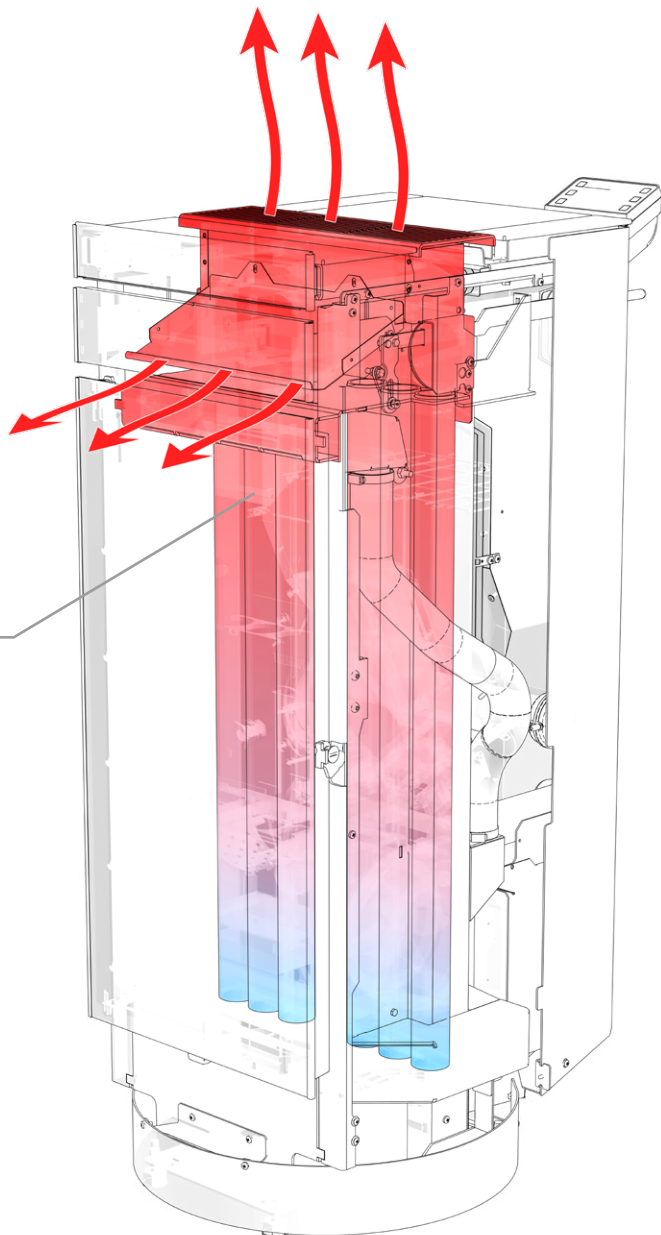

Più silenziosa che mai: i nostri prodotti già silenziosissimi da oggi si possono scegliere in due nuove tecnologie: Natural Air e Natural Plus

Plus silencieux que jamais : nos produits, déjà très silencieux, peuvent désormais être choisis avec 2 nouvelles technologies : Natural Air et Natural Plus

Quieter than ever: our very quiet products can now be chosen in 2 new technologies: Natural Air and Natural Plus

Leiser denn je: unsere bereits sehr leisen Produkte können jetzt in 2 neuen Technologien gewählt werden: Natural Air und Natural Plus

Más silencioso que nunca: nuestros productos, ya muy silenciosos, se pueden elegir ahora con 2 nuevas tecnologías: Natural Air y Natural Plus

NATURAL AIR

- ITA Funzione Natural Air: puoi riscaldarti in assoluto silenzio disattivando il ventilatore e usufruire così del calore diffuso dalla convezione naturale. Ma se hai una vita frenetica e tempi di riscaldamento brevi, ti basta un semplice gesto per riscaldare casa velocemente grazie all'uso della ventilazione forzata.
- FRA Fonction Natural Air : vous pouvez vous chauffer dans un silence absolu, en arrêtant le ventilateur, et profiter ainsi de la chaleur diffusée par la convection naturelle. Mais si vous avez une vie trépidante et des temps de chauffage brefs, il suffit d'un simple geste pour chauffer rapidement votre maison, grâce à l'utilisation de la ventilation forcée.
- ENG Natural Air function: you can heat yourself in absolute silence by turning off the fan and take advantage of the heat diffused by natural convection. But if you have a busy life and short heating times, all you need is a simple gesture to heat your home quickly thanks to the use of forced ventilation.
- DEU Funktion Natural Air: Sie können sich in absoluter Stille erwärmen, indem Sie den Ventilator ausschalten und die durch natürliche Konvektion verbreitete Wärme nutzen. Aber wenn Sie ein hektisches Leben und kurze Heizzeiten haben, brauchen Sie nur eine einfache Geste, um Ihr Haus dank der Zwangslüftung schnell zu heizen.
- ESP Función Natural Air: puede calentarse en absoluto silencio, apagando el ventilador y aprovechando el calor difundido por convección natural. Pero si usted tiene una vida frenética y tiempos de calefacción cortos, todo lo que necesita es un simple gesto para calentar su casa rápidamente gracias al uso de la ventilación forzada.



16m x 1
8m x 2

16 metri di canalizzazione utilizzando 1 uscita
8 metri di canalizzazione utilizzando 2 uscite
16 mètres de canalisation avec 1 sortie
8 mètres de canalisation avec 2 sorties
16 meters of ducting using 1 outlet
8 meters of ducting using 2 outlets

+40%
heat exchange
surface

NATURAL PLUS

ITA Funzione Natural Plus: puoi riscaldarti in assoluto silenzio disattivando il ventilatore e usufruire così del calore diffuso dalla convezione naturale. Con un semplice gesto puoi decidere di riscaldare più ambienti di casa velocemente grazie all'uso della ventilazione forzata e alla gestione delle due canalizzazioni.

FRA Fonction Natural Plus : vous pouvez vous chauffer dans un silence absolu, en arrêtant le ventilateur, et profiter ainsi de la chaleur diffusée par la convection naturelle. D'un simple geste, vous pouvez décider de chauffer rapidement plusieurs pièces de la maison, grâce à l'utilisation de la ventilation forcée et à la gestion des deux conduits de canalisation.

ENG Natural Plus function: you can heat yourself in absolute silence by turning off the fan and take advantage of the heat diffused by natural convection. With a simple gesture you can decide to heat more rooms in your home quickly thanks to the use of forced ventilation and the management of the two ducts.

DEU Funktion Natural Plus: Sie können sich in absoluter Stille erwärmen, indem Sie den Ventilator ausschalten und die durch natürliche Konvektion verbreitete Wärme nutzen. Mit einer einfachen Geste können Sie schnell entscheiden, mehrere Räume in Ihrem Haus zu heizen, dank der Verwendung von Zwangslüftung und der Verwaltung der beiden Kanäle.

ESP Función Natural Plus: puede calentarse en absoluto silencio, apagando el ventilador y aprovechando el calor difundido por convección natural. Con un simple gesto, puede decidir calentar más habitaciones rápidamente, gracias al uso de la ventilación forzada y a la gestión de los dos conductos de canalización.

Scatola di distribuzione
dell'aria canalizzata
Boîte de distribution
de l'air canalisé
Air ducting distribution box

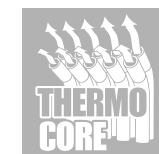
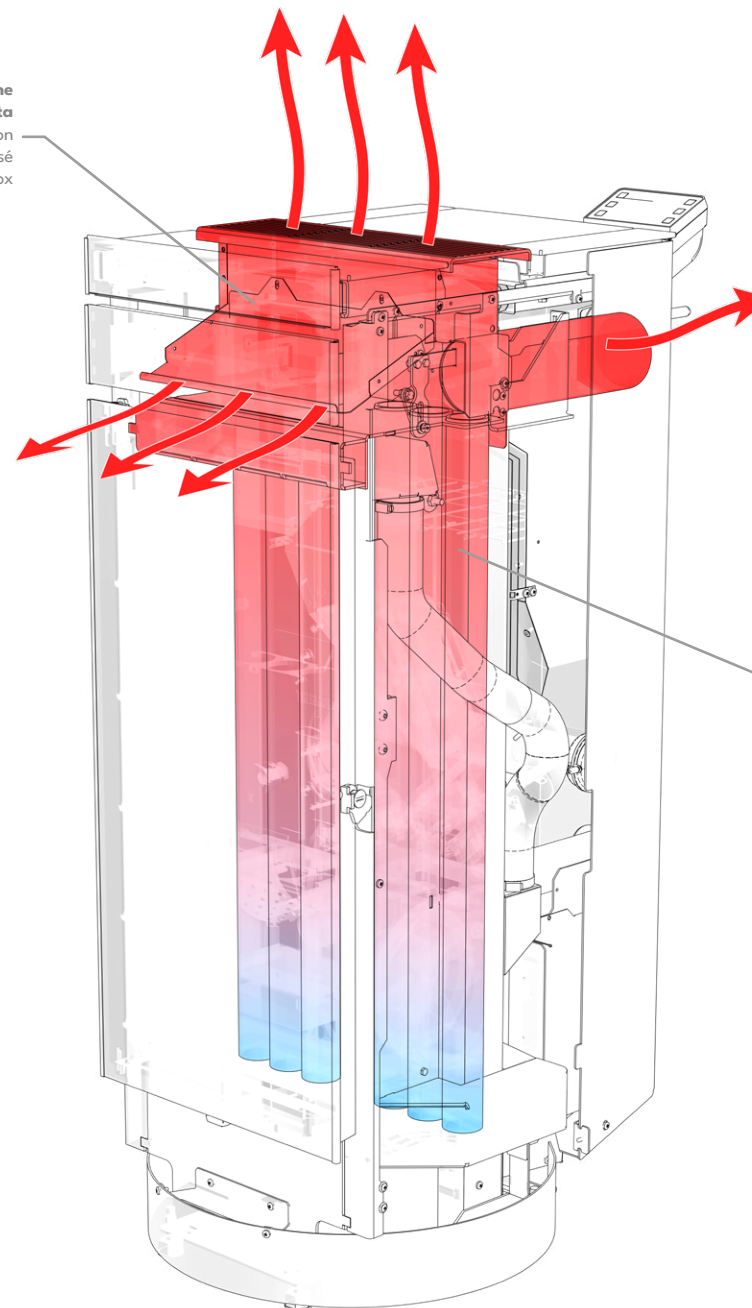

Scambiatore a fascio
tubiero THERMOCORE®
Échangeur de chaleur
à faisceau tubulaire
THERMOCORE®
pipe heat exchanger

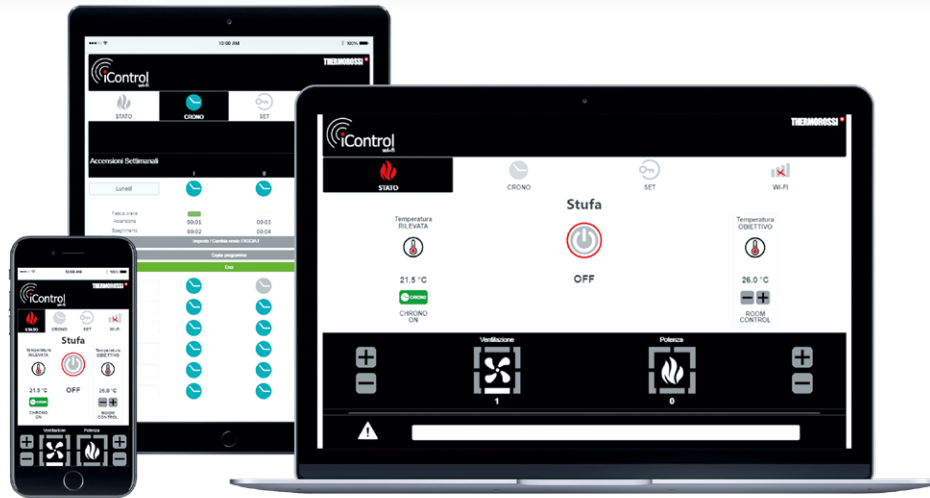

wi-fi module & web-app

iControl

ITA La tua stufa a portata di smartphone! Ovunque tu sia tutto è sotto controllo. In esclusiva la Web-App Thermorossi iControl assieme al modulo wi-fi (optional) consente di gestire comodamente la tua stufa tramite smartphone, tablet e desktop. L'utilizzo di questa applicazione è semplice e intuitivo e permette in ogni momento di connettersi alla stufa di casa per attivare a distanza numerose funzioni. Accendere e spegnere la tua stufa. Impostare la temperatura ambiente se è presente il Room Control (optional). Impostare le fasce orarie di funzionamento su base giornaliera e/o settimanale. Verificare lo stato di funzionamento della stufa ed eventuali allarmi.

FRA Votre poêle à portée de smartphone ! Où que vous soyez, tout est sous contrôle. En exclusivité, l'appli Thermorossi iControl associée au module wi-fi (en option) vous permet de gérer confortablement votre poêle via un smartphone ou une tablette, et bureau. L'utilisation de cette application est simple et intuitive, et vous permet de vous connecter au poêle de la maison à tout moment, pour activer de nombreuses fonctions à distance : Allumer et éteindre votre poêle. Régler la température ambiante (en présence du Room Control - en option). Régler les horaires de fonctionnement sur base quotidienne et/ou hebdomadaire. Vérifier l'état de fonctionnement du poêle et les éventuelles alertes.

ENG Your stove on your smartphone! Wherever you are, everything is under control. Exclusively the Thermorossi iControl Web-App together with the wi-fi (optional) module allows you to comfortably manage your stove via smartphone, tablet and desktop. The use of this application is simple and intuitive and allows you to connect to your home stove at any time to activate many functions remotely. Turn your stove on and off. Set the room temperature if Room Control is present (optional). Set the operating hours on a daily and/or weekly basis. Check the operating status of the stove and any alarms.

DEU Ihr Ofen in Reichweite Ihres Smartphones! Wo auch immer sie sind, alles ist unter Kontrolle. Exklusiv die Thermorossi iControl Web-App zusammen mit dem Wi-Fi-Modul (fakultativ) ermöglicht Ihnen die komfortable Verwaltung Ihres Kaminofens per Smartphone, Tablet und Desktop. Die Nutzung dieser Anwendung ist einfach und intuitiv und ermöglicht es Ihnen, sich jederzeit mit Ihrem Ofen zu Hause zu verbinden, um viele Funktionen aus der Ferne zu aktivieren. Schalten Sie Ihren Ofen ein und aus. Einstellung der Raumtemperatur bei vorhandener Raumregelung (fakultativ). Die Betriebsstunden täglich und/oder wöchentlich einstellen. Überprüfen Sie den Betriebszustand des Kaminofens und eventuelle Alarme.

ESP Su estufa en su smartphone! En cualquier lugar sea, todo está bajo control. En exclusiva la web-app Thermorossi iControl junto con el módulo wi-fi (opcional) le permite gestionar cómodamente su estufa a través de un smartphone o de una tableta y desktop. El uso de esta aplicación es simple e intuitivo y le permite conectarse a la estufa de su casa en cualquier momento para activar varias funciones a distancia: Encender y apagar la estufa. Ajustar la temperatura de la habitación (si el Room control está presente - opcional). Ajustar las horas de funcionamiento diariamente y/o semanalmente. Comprobar el estado de funcionamiento de la estufa y las posibles alarmas.



Disponibile su:
Disponibile sur:
Available on:
Verfügbar unter:
Disponibile en:





Temperature Remote Sensor

Room Control

- ITA** Termostato ambiente wireless a batterie (optional), senza fili facile da installare con supporto a muro. Imposta la temperatura desiderata sul display della stufa ed il calore di casa è sempre sotto controllo. Room Control permette di ottenere il miglior confort per tua stufa e con l'app esclusiva iControl avrai la possibilità di regolare la temperatura a distanza. Potrai modificare la temperatura nell'ambiente in qualunque momento, nel tuo salotto o dall'altra parte del mondo.
- FRA** Thermostat d'ambiance wireless (en option), sur pile, sans fil, simple à installer, avec son support mural. Il règle la température désirée sur l'écran du poêle, et la chaleur dans la maison est toujours sous contrôle. Le Room Control permet d'obtenir le meilleur confort de votre poêle ; et avec l'application exclusive iControl, il permet de régler la température à distance. Vous pouvez changer la température ambiante à tout moment, dans votre salon ou à l'autre bout du monde.
- ENG** Room wireless Thermostat (optional), battery powered, easy to install with its wall support. It set the desired temperature on the display of the stove and the heat inhouse is always under control. The Room Control offers the best comfort and with the exclusive iControl app, it allows temperature adjustments remotely. You can change the temperature in the room at any time, when you are in your living room or on the other side of the world.
- DEU** Batteriebetriebener, kabelloser Raumthermostat (fakultativ), einfach zu installieren mit Wandhalterung. Stellen Sie die gewünschte Temperatur auf dem Display des Ofens ein und die Wärme des Hauses ist immer unter Kontrolle. Mit der Raumsteuerung können Sie den besten Komfort für Ihren Kaminofen erhalten und mit der exklusiven iControl-App die Temperatur ferngesteuert einstellen. Sie können die Temperatur im Raum jederzeit ändern, in Ihrem Wohnzimmer oder auf der anderen Seite der Welt.
- ESP** Termostato de habitación wireless (opcional), con batería, fácil de instalar con su soporte de pared. Regula la temperatura deseada en la pantalla de la estufa, y el calor en la casa está siempre bajo control. El Room Control permite obtener el mejor confort de su estufa y, con la exclusiva aplicación iControl, permite ajustar la temperatura a distancia. Puede ajustar la temperatura de la habitación en cualquier momento, en su sala o al otro lado del mundo.





10 TECHNOLOGIES



Idra
14-18-21 kW



Air



Wood
6-8-10 kW



Plus



Natural Plus
12kW



Natural Air
12kW

Change look whenever you want **Multi Dress Code**

- ITA Ami cambiare stile e tecnologia? Grazie ad un accurato studio di progettazione ingegneristica è possibile intercambiare più rivestimenti con diverse modalità di riscaldamento (aria, convezione naturale, acqua). Scegli la tua tecnologia e cambia lo stile come e quando vuoi tu.
- FRA Aimez-vous changer de style et de technologie ? Grâce à une conception technique soignée, vous pouvez interchanger plusieurs revêtements avec différents modes de chauffage (air, convection naturelle, eau). Choisissez votre technologie et changez le style comme et quand vous le souhaitez.
- ENG Do you like to change style and technology? Thanks to an accurate engineering design study, it is possible to interchange several coverings with different heating modes (air, natural convection, water). Choose your technology and change the style as and when you want to.
- DEU Lieben Sie es Style und Technik zu wechseln? Dank unseres innovativen Plattform-Designs ist es möglich unsere verschiedenen Verkleidungssysteme (Kacheln, Naturstein und Metallverkleidungen) mit den verschiedenen Kaminofenvarianten (Pellets, Luft und Wasser geführt sowie Kaminholz) zu kombinieren. Wählen Sie unsere Technik und wechseln Sie Ihren Style nach Lust und Bedarf.
- ESP ¿Le gusta cambiar de estilo y de tecnología? Gracias a un cuidadoso diseño de ingeniería, puede intercambiar varias cubiertas con diferentes modos de calefacción (aire, convección natural, agua). Elige su tecnología y cambia el estilo como y cuando quiera.



DORICA
air
plus
natural air 12 (kW)
natural plus 12 (kW)
idra 14-18-21 (kW)
wood 6-8-10 (kW)



MOMA
air
plus
natural air 12 (kW)
natural plus 12 (kW)
idra 14-18-21 (kW)
wood 6-8-10 (kW)

CHIC
air
plus
natural air 12 (kW)
natural plus 12 (kW)
idra 14-18-21 (kW)
wood 6-8-10 (kW)



CREO
air
plus
natural air 12 (kW)
natural plus 12 (kW)
idra 14-18-21 (kW)
wood 6-8-10 (kW)



326 COMBINATIONS

LIENZ
air
plus
idra 14-18-21 (kW)
wood 6-8-10 (kW)



SAINT MORITZ
air
plus
natural air 12 (kW)
natural plus 12 (kW)
idra 14-18-21 (kW)
wood 6-8-10 (kW)



ESSENZA
air
plus
natural air 12 (kW)
natural plus 12 (kW)
idra 14-18-21 (kW)
wood 6-8-10 (kW)





Idra
Home

THERMOCELL® 250
THERMOCELL® 400
THERMOCELL® 500

Accumuli a stratificazione
Ballon d'Accumulation à stratification
Stratification thermal stores
Geschichtete termische Pufferspeichern
Acumulaciòn tèrmico a estratificaciòn

THERMOPUFFER 400
THERMOPUFFER 500
THERMOPUFFER 1500

Accumulo (puffer)
Reservoir d'accumulation (puffer)
Puffer tank
Pufferspeicher
Estanque (puffer)

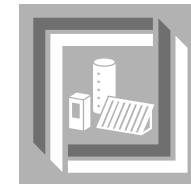

INTEGRA TR-PACK

- ITA Generatore a pellet abbinato a pannelli solari e accumuli. L'impianto termoidraulico deve essere realizzato secondo normativa locale e dotato di tutti gli accessori di sicurezza e controllo.
- FRA Générateurs de chaleur à pellet accouplée aux panneaux solaire. L'installation de chauffage doit être réalisée suivant les réglementations locales et avoir tous les systèmes de sécurité et contrôle.
- ENG Pellet boiler paired to solar heating system. All installations must be realized following local current normative and must be provided with check up and safety instruments.
- DEU Pelletwärmegerzeuger mit Solar- und Speicheranschluss. Die Heizanlage muss die geltenden Bestimmungen befolgen und mit allen lokalen Sicherheits- und Kontrollelementen versehen sein.
- ESP Calentador de pellets combinado con placa solar. Cada instalación termohidráulica tiene que ser realizada según normativa local y dotada de todos los accesorios de seguridad y control.



THERMO SOLE®2.0

Collettore solare
Panneaux solaire
Solar heating unit
Solarkollektoren
Placa solar

THERMOCELL® FLAT 250

Accumulo a stratificazione
Ballon d'Accumulation à stratification
Stratification thermal stores
Geschichtete termische Pufferspeichern
Acumulaciòn tèrmico a estratificaciòn



Idra
Home

Fino a 140 m²
Example 1 - Up to 140 m²

Esempio 1

ITA - Soluzione a risparmio energetico alternativa ed ecologica al tradizionale sistema di riscaldamento con caldaia a pellet dotata di bruciatore brevettato, accumulo a stratificazione, pannelli solari termici.

FRA - Solution à économie d'énergie, écologique et alternative au système de chauffage traditionnel, composée d'une chaudière à granulés dotée de brûleur breveté, d'un ballon d'accumulation à stratification naturelle, et de panneaux solaires thermiques.

ENG - Energy saving solution which offers an ecological alternative to the traditional heating systems, consisting in a pellet boiler with patented burner, stratification water storage, solar heating units.

- 1 Pidra14, Pidra18, Pidra21
- 2 Thermocel® 250
- 3 Thermosole 2.0

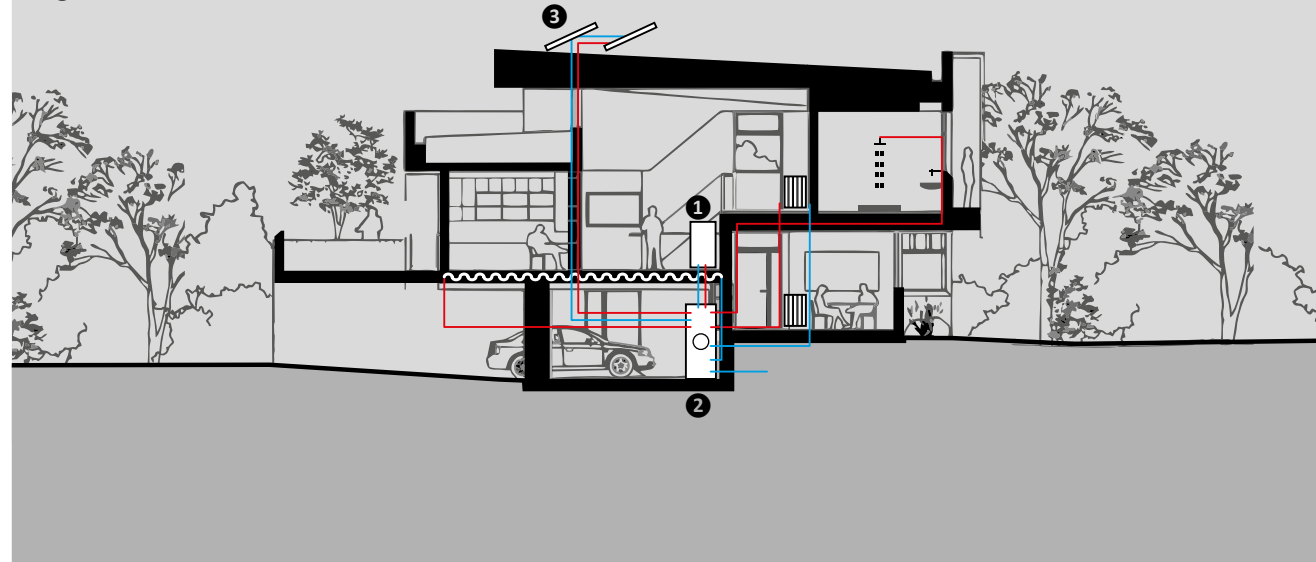

Fino a 265 m²
Example 2 - Up to 265 m²

Esempio 2

ITA - Soluzione a risparmio energetico alternativa ed ecologica al tradizionale sistema di riscaldamento con prolungata autonomia grazie alla caldaia a pellet con bruciatore brevettato, accumulo a stratificazione, pannelli solari termici e serbatoio pellet aggiuntivo fino a 100 kg.

FRA - Solution à économie d'énergie, écologique et alternative au système de chauffage traditionnel, à autonomie prolongée, composée d'une chaudière à granulés dotée de brûleur breveté, d'un ballon d'accumulation à stratification naturelle, de panneaux solaires thermiques, et d'un réservoir à granulés supplémentaire d'une capacité de 100 kg.

ENG - Energy saving solution which offers an ecological alternative to the traditional heating systems, granting a longer autonomy thanks to the pellet boiler with patented burner, stratification water storage, solar heating units and extra pellet tank up to 100 Kg of capacity.

- 1 Insertidramaxi
- 2 Thermocel® 400
- 3 Thermosole 2.0

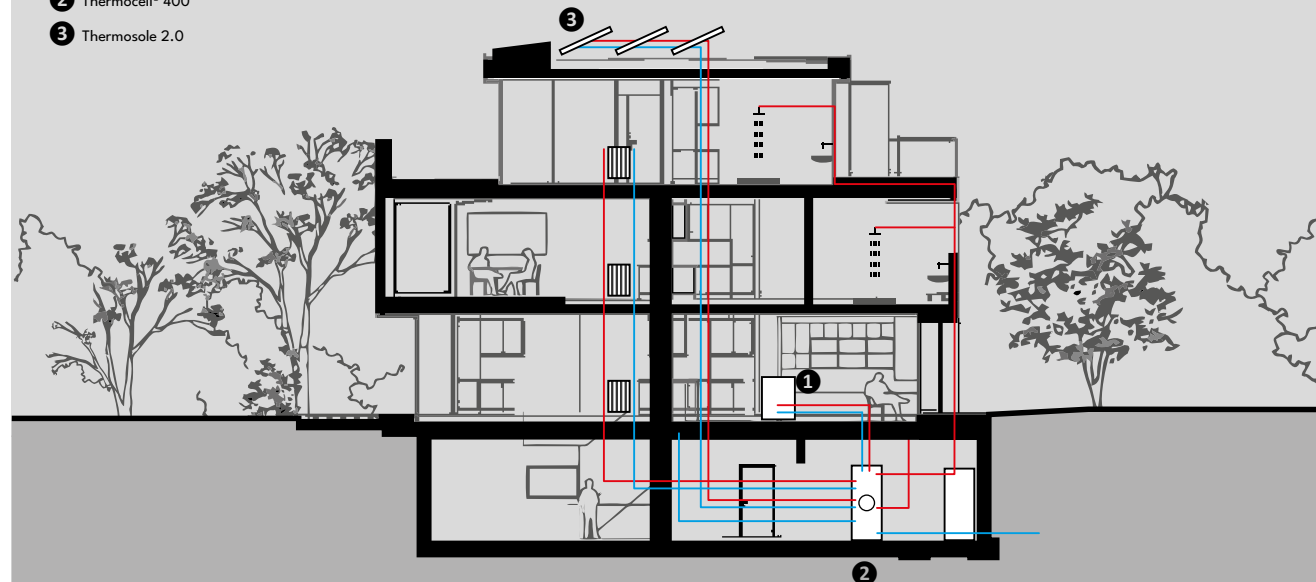

A+ A++
↑
G



air



URBAN Evo6

ITA Riscaldare casa risparmiando non significa rinunciare alla qualità. URBAN è la soluzione bella e funzionale con il giusto rapporto qualità-prezzo. Una stufa adatta a tutte le tasche!

FRA Chauffer la maison tout en économisant ne signifie pas renoncer à la qualité. URBAN est la solution belle et fonctionnelle, avec le juste rapport qualité-prix. Un poêle qui s'adapte à toutes les poches!

ENG Heating your home while saving money doesn't mean giving up quality. URBAN is the beautiful and functional solution with the right ratio quality-price. A stove that fits all pockets!

DEU Heizen und gleichzeitig Geld sparen heißt nicht, auf Qualität zu verzichten. URBAN ist die schöne und funktionelle Lösung mit dem richtigen Verhältnis von Qualität-Preis. Ein Ofen, der in jede Tasche passt!

ESP Calentar su casa mientras ahorra dinero no significa renunciar a la calidad. URBAN es la solución bella y funcional, con la adecuada relación calidad-precio. ¡Una estufa para todos los bolsillos!

Uscite fumi disponibili:

posteriore - laterale sinistro salvaspazio (optional)

Sorties des fumées disponibles:

postérieure - latérale pour réduire l'encombrement gauche (option)

Flue outlet options:

rear - left side space-saving (optional)

Coperchio con chiusura ermetica
Couvricle étanche
Lid with hermetic closure

Preziosa porta focolare in cristallo e ghisa
Porte de foyer en fonte et cristal imprimé en sérigraphie
Precious glass and cast iron firebox door

Maniglia removibile. Essenzialità nel design e maggior sicurezza
Poignée amovible. Design essentiel et sécurité accrue
Removable handle. Essentiality in design and greater safety

Schermo comandi programmabile
Panneau des commandes programmable
Programmable control screen

Bruciatore in ghisa
Brûleur en fonte
Cast iron burner



OPTIONAL:



iCONTROL

Sistema wi-fi iControl con web-App

Système wi-fi iControl avec web-App

Wi-fi system iControl with web-App

Wi-Fi System iControl mit web-App

Sistema wi-fi iControl con web-App



ROOM CONTROL

Termostato ambiente wireless con supporto a muro

Thermostat d'ambiance wireless avec support mural

Room wireless Thermostat with its wall support

Kabelloser Raumthermostat mit Wandhalterung

Termostato de habitación wireless con su soporte de pared



Installazione salva spazio, curva 90° per scarico fumi laterale sinistro

Installation compacte, coude à 90°

pour l'évacuation des gaz de combustion à gauche

Space-saving installation,

90° curved pipe for left-side flue outlet

Matt Black

Bianco

Bordeaux

Bronze



59



903x439x467



2,5 - 7,3



2,4 - 6,6



0,52 - 1,55



17

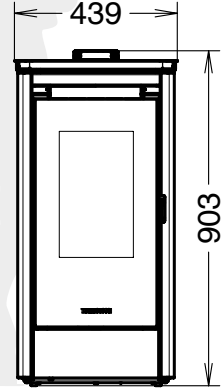
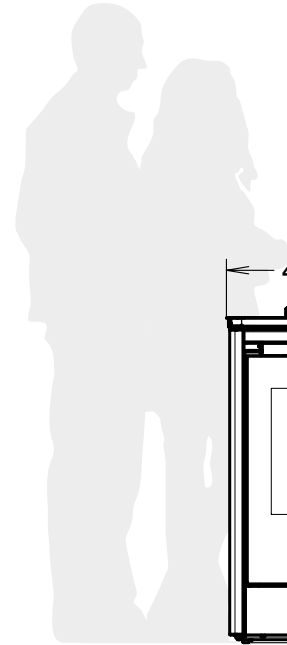

CSTB BlmSchV II
le futur en construction





A+ A++
↑
G

plus

5000 Easy

ITA Le finiture curate permettono di integrare 5000 Easy in qualsiasi ambiente.

FRA Grâce à ses finitions soignées, les 5000 Easy peut être intégré dans n'importe quel milieu.

ENG Its meticulous finish with bas-relief details make it the perfect unit for any room.

DEU Die sorgfältigen bearbeiteten Flächen bieten die Möglichkeit den 5000 in den Easy Verkleidungen in jede Umgebung integrieren an.

ESP Los esmerados acabados con especiales mecanizaciones en bajo relieve permiten integrar 5000 Easy en cualquier ambiente.

Canalizzazioni disponibili: due uscite posteriori

Deux conduits d'air postérieurs

Duct vents options: two rear

Schermo comandi programmabile

Panneau des commandes programmable
Programmable control screen

Porta focolare ghisa

Porte de foyer en fonte
Cast iron firebox door

Bruciatore in ghisa

Brûleur en fonte
Cast iron burner

Ampio cassetto cenere estraibile

Ample tiroir des cendres extractible
Removable spacious ash tray

Maniglia antiscottatura

Poignée main-froide
Anti-burn door handle

OPTIONAL:



iCONTROL

Sistema wi-fi iControl con web-App

Système wi-fi iControl avec web-App

Wi-fi system iControl with web-App

Wi-Fi System iControl mit web-App

Sistema wi-fi iControl con web-App



ROOM CONTROL

Termostato ambiente wireless con supporto a muro

Thermostat d'ambiance wireless avec support mural

Room wireless Thermostat with its wall support

Kabelloser Raumthermostat mit Wandhalterung

Termostato de habitación wireless con su soporte de pared

Grigio
antracite

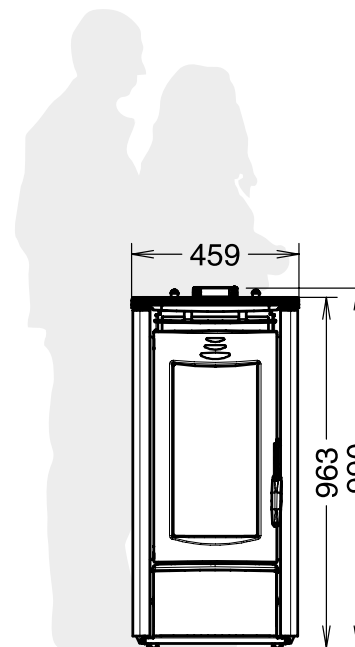

BImSchV II



15m¹
5m²



83



990x459x577



3 - 10,2



2,5 - 9,2



0,7 - 2,3



14,5

A+ A++
↑
G



plus

7000 Evo Easy

- ITA Stufa a pellet canalizzabile, diventa protagonista della vostra casa. Ideale per chi vuole distribuire il calore in ambienti diversi e riscaldare più locali, basta un semplice gesto per indirizzare il flusso d'aria verso le canalizzazioni.
- FRA Poêle à granulés canalisable, il devient le protagoniste de votre maison. Idéal pour ceux qui veulent distribuer la chaleur dans différents environnements et chauffer plusieurs pièces, un simple geste suffit pour diriger le flux d'air vers les conduits.
- ENG Ducted pellet stove, becomes the protagonist of your home. Ideal for those who want to distribute heat in different environments and heat multiple rooms, a simple gesture is enough to direct the airflow towards the ducts.
- DEU Kanalisierbarer Pelletofen, wird zum Protagonisten Ihres Hauses. Ideal für diejenigen, die Wärme in verschiedenen Umgebungen verteilen und mehrere Räume heizen möchten, eine einfache Geste genügt, um den Luftstrom zu den Kanälen zu lenken.
- ESP Estufa de pellets canalizable, se convierte en la protagonista de su hogar. Ideal para quienes desean distribuir el calor en diferentes ambientes y calentar varias habitaciones, basta un simple gesto para dirigir el flujo de aire hacia los conductos.

Canalizzazioni disponibili: due uscite posteriori
 Deux conduits d'air postérieurs
 Duct vents options: two rear

Schermo comandi programmabile
 Panneau des commandes programmable
 Programmable control screen

Porta focolare ghisa
 Porte de foyer en fonte
 Cast iron firebox door

Bruciatore in ghisa
 Brûleur en fonte
 Cast iron burner

Maniglia antiscottatura
 Poignée main-froide
 Anti-burn door handle



OPTIONAL:



iCONTROL
Sistema wi-fi iControl con web-App
 Système wi-fi iControl avec web-App
 Wi-fi system iControl with web-App
 Wi-Fi System iControl mit web-App
 Sistema wi-fi iControl con web-App



ROOM CONTROL
Termostato ambiente wireless con supporto a muro
 Thermostat d'ambiance wireless avec support mural
 Room wireless Thermostat with its wall support
 Kabelloser Raumthermostat mit Wandhalterung
 Termostato de habitación wireless con su soporte de pared

Matt
 Black

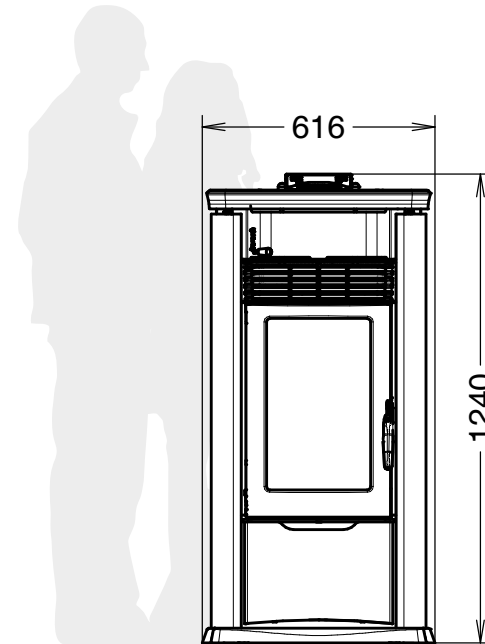

- 114
- mm
- 1240x616x644
- 3,6 - 13,6
- kW NOM. 3,4 - 12,7
- 0,74 - 2,82
- 30

Eco DESIGN 2022

5 STELLE
DM 186/7

7 ÉTOILES

9 mg/m³
13% di O₂

CSTB BlmSchV II
 le futur en construction



natural air



CHICCA

- ITA Grazie all'altezza contenuta è la stufa perfetta per mansarde, sottoscale o semplicemente per chi vuole recuperare un focolare esistente. Dotata di bruciatore autopulente fino a 500 ore NO-STOP, ermetica, fiamma emozionale, scambiatore di calore a fascio tubiero, facilità di pulizia ordinaria e straordinaria, predisposizione wi-fi tecnologia.
- FRA Grâce à sa hauteur contenue, c'est le poêle parfait pour des mansardes, des dessous d'escalier ou simplement pour qui veut récupérer un foyer existant. Doté de brûleur autonettoyant jusqu'à 500 heures NON-STOP, hermétique, flamme émotionnelle, échangeur de chaleur à faisceau tubulaire, nettoyages ordinaire et extraordinaire faciles, prédisposition à la technologie Wi-Fi.
- ENG The stove's compact height makes it the perfect solution for attics, under stairs or simply for those who want to bring an existing fireplace back to life. Fitted with a self-cleaning burner with up to 500 hours NON-STOP operation, hermetically sealed, emotional flame, tube heat exchanger, easy routine and extraordinary cleaning, provision for Wi-Fi technology.
- DEU Dank seiner geringen Höhe ist der Ofen ideal für Mansarden, unterhalb von Treppen oder einfach für denjenigen, der eine bestehende Feuerstelle nutzen möchte. Selbstreinigender Brenner, für bis zu 500 Stunden NON-STOP, luftdicht, angenehmes Flammenbild, Rohrbündelwärmetauscher, leichte ordentliche und außerordentliche Reinigung, Wi-Fi-Anschluss möglich.
- ESP Gracias a su altura reducida, es la estufa ideal para áticos, espacios debajo de escaleras o simplemente para quienes desean reutilizar un hogar preexistente. Dotada de quemador autolimpiante capaz de funcionar hasta 500 horas NON-STOP, hermética, llama emocional, intercambiador de calor tubular, facilidad de limpieza ordinaria y extraordinaria, predisposición para tecnología wifi.

Uscite fumi disponibili:

- superiore centrale integrata Ø80mm
- posteriore Ø80mm

Sorties des fumées disponibles :

- central supérieur intégré Ø80mm / coaxial Ø125-130mm
- arrière Ø80mm

Flue outlet options:

- upper central integrated Ø80mm / coaxial Ø125-130mm
- rear Ø80mm



Schermo comandi programmabile

Panneau des commandes programmable
Programmable control screen

Coperchio superiore in ghisa con accesso scorrevole per il caricamento del pellet

Couvercle supérieur en fonte avec accès coulissant pour le chargement des granulés
Cast iron sliding access top cover for loading pellets

Scambiatore a fascio tubiero THERMOCORE®

Échangeur de chaleur à faisceau tubulaire THERMOCORE®
pipe heat exchanger

Bruciatore autopulente brevettato Pelletpower®

Brûleur autonettoyant breveté Pelletpower®
Pelletpower® patented self-cleaning burner

L'elegante design rialzato della base facilita la pulizia

L'élégant design rehaussé de la base simplifie l'entretien
The refined raised base facilitates the cleaning operations

OPTIONAL:



iCONTROL

Sistema wi-fi iControl con web-App
Système wi-fi iControl avec web-App
Wi-fi system iControl with web-App
Wi-Fi System iControl mit web-App
Sistema wi-fi iControl con web-App



ROOM CONTROL

Termostato ambiente wireless con supporto a muro

Thermostat d'ambiance wireless avec support mural
Room wireless Thermostat with its wall support
Kabelloser Raumthermostat mit Wandhalterung
Termostato de habitación wireless con su soporte de pared

Matt
Black

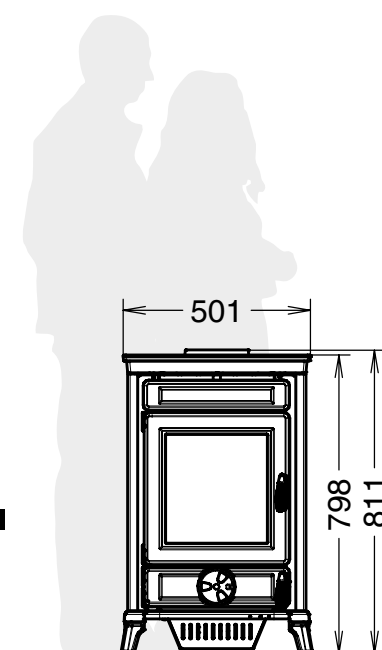

- 65
- mm
- 798x501x642
- kW
- 2,3 - 7,9
- kW NOM.
- 2,1 - 7,2
- 0,5 - 1,6
- 15



CSTB BlmSchV II
le futur en construction



A+ A++
↑
G



plus

MOOD® Plus Evo

ITA Forme curate, finiture dal forte carattere materico e raffinate tinte monocromatiche fanno di Mood® una stufa a pellet canalizzabile dal design attuale e contemporaneo concepita per tutti gli spazi, dai piccoli ambienti ai grandi loft. Thermorossi dimostra continuamente la propria attenzione a percorrere nuove vie, con tecniche innovative e un design straordinario in grado di aprire nuovi segmenti di mercato.

FRA Des formes soignées, des finitions au caractère fortement matériel, et des teintes monochromes raffinées, font du Mood® un poêle à granulés canalisable au design actuel et contemporain conçu pour tout milieu, de la petite salle au grand loft. Thermorossi démontre continuellement son engagement à parcourir de nouvelles voies, avec des techniques innovantes et un design extraordinaire capables d'ouvrir de nouveaux segments de marché.

ENG Meticulous finishes with strong materials and refined monochromatic paints make Mood® an air-ducting pellet stove with a modern design, thought to be suitable for every style of home, from a small house to the spacious loft. Thermorossi assures its constant and continuous attention to pursue new paths, ever innovative, improved technical solutions and outstanding design, in order to open up new segments of the market.

DEU Feine Oberflächen aus starkem Material und raffinierte harmonische Farben machen Mood®, ein kanalisierbarer Pelletofen mit modernem Design, zu einem Begleiter in jedem Haus. Er ist sowohl für kleine als auch für mittlere Räumlichkeiten die richtige Wahl. Thermorossi strebt stets und konstant neue Wege an, um immer innovativere und technisch bessere Lösungen mit herausragendem Design anbieten zu können, wodurch neue Marktsegmente erschlossen werden können.

ESP Formas cuidadas, acabados con fuerte carácter artístico y refinados colores monocromos hacen de Mood® una estufa de pellets canalizada de diseño actual y contemporáneo, concebida para todos los entornos, desde la habitación pequeña hasta el gran loft. Thermorossi demuestra continuamente su atención a nuevos enfoques, con técnicas innovadoras y un diseño único que puede abrir nuevos segmentos de mercado.



Una canalizzazione posteriore
Un conduit d'air postérieurs
One rear hot air ducting outlet

Uscita fumi centrale o posteriore
Sortie des fumées centrale ou postérieure
Central smoke outlet or rear

Piano igienico, in cristallo con funzione di scalda vivande
Chauffe-plats hygiénique, en cristal
Practical food warming plate in hygienic glass

Bruciatore in ghisa
Brûleur en fonte
Cast iron burner

Design attuale e contemporaneo grazie ai piedini in pregiato legno
Design actuel et contemporain grâce aux pieds en bois précieux
Modern design given by the feet in high quality wood

Schermo comandi programmabile
Panneau des commandes programmable
Programmable control screen

Accesso scorrevole per il caricamento del pellet
Accès coulissant pour chargement de granulés
Sliding top access to the pellet tank

Maniglia removibile. Essenzialità nel design e maggior sicurezza
Poignée amovible.
Design essentiel et sécurité accrue
Removable door handle. Essential design and high safety

L'elegante design rialzato della base facilita la pulizia
L'élégant design rehaussé de la base simplifie l'entretien
The refined raised base facilitates the cleaning operations

OPTIONAL:



iCONTROL
Sistema wi-fi iControl con web-App
Système wi-fi iControl avec web-App
Wi-fi system iControl with web-App
Wi-Fi System iControl mit web-App
Sistema wi-fi iControl con web-App



ROOM CONTROL
Termostato ambiente wireless con supporto a muro
Thermostat d'ambiance wireless avec support mural
Room wireless Thermostat with its wall support
Kabelloser Raumthermostat mit Wandhalterung
Termostato de habitación wireless con su soporte de pared

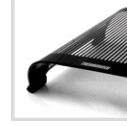

DINNER
Coperchio scalda vivande in cristallo
Couvercle chauffe-plat en cristal
Glass food-warming cover
Warmhalteplatte aus Kristallglas
Chapa para calentar comidas



Teo ridotto per installazione scarico fumi centrale superiore
Joint en "T" réduit pour sortie centrale supérieure de fumées
Reduced "T" joint for central upper smoke extraction outlet

Matt Black

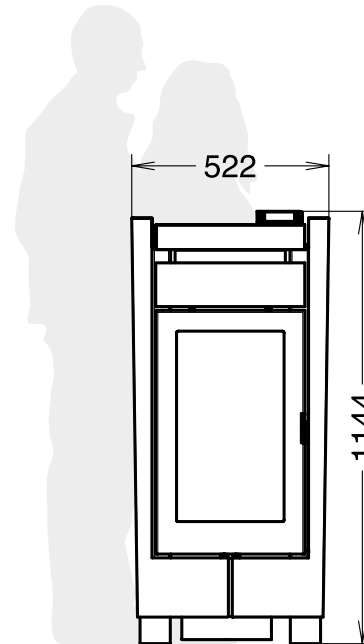

90



1144x522x554



3,3 - 10,9



2,9 - 10,0



0,7 - 2,3



16

Eco DESIGN 2022 **5 STELLE DM 186/7** **7 ÉTOILES** **POLVERI 9 mg/m³ 13% di O₂** **BlmSchV II**

A+ A++
↑
G



natural plus

MOVIDA Evo6

ITA Stufa a pellet ermetica e canalizzabile dotata di bruciatore autopulente fino a 500 ore NO-STOP. Fiamma emozionale, funzione Natural a qualsiasi potenza, scambiatore di calore a fascio tubiero, facilità di pulizia ordinaria e straordinaria, predisposizione wi-fi technology.

FRA Poêle à granulés étanche et canalisable, doté de brûleur autonettoyant jusqu'à 500 heures NON-STOP. Flamme émotionnelle, fonction Natural à tous les niveaux de puissance, échangeur de chaleur à faisceau tubulaire, nettoyages ordinaire et extraordinaire faciles, prédisposition à la technologie Wi-Fi.

ENG Hermetically sealed and ductable pellet stove fitted with a self-cleaning burner with up to 500 hours NON-STOP operation. Emotional flame, Natural function at any power, tube heat exchanger, easy routine and extraordinary cleaning, provision for Wi-Fi technology.

DEU Luftdichter und kanalisierbarer Pelletheizofen mit selbstreinigendem Brenner für bis zu 500 Stunden NON-STOP. Angenehmes Flammenbild, Funktion „Natural“ bei jeder Leistung, Rohrbündelwärmetauscher, leichte ordentliche und außerordentliche Reinigung, Wi-Fi-Anschluss möglich.

ESP Estufa de pellets hermética y canalizable, dotada de quemador autolimpiante capaz de funcionar hasta 500 horas NON-STOP. Llama emocional, función Natural a cualquier potencia, intercambiador de calor tubular, facilidad de limpieza ordinaria y extraordinaria, predisposición para tecnología wifi.

Uscite fumi disponibili:

- superiore centrale integrata Ø80mm
- posteriore Ø80mm

- Sorties des fumées disponibles :
- central supérieur intégré Ø80mm / coaxial Ø125-130mm
 - arrière Ø80mm

- Flue outlet options:
- upper central integrated Ø80mm / coaxial Ø125-130mm
 - rear Ø80mm

Una canalizzazione posteriore

- Un conduit d'air postérieurs
- One rear hot air ducting outlet

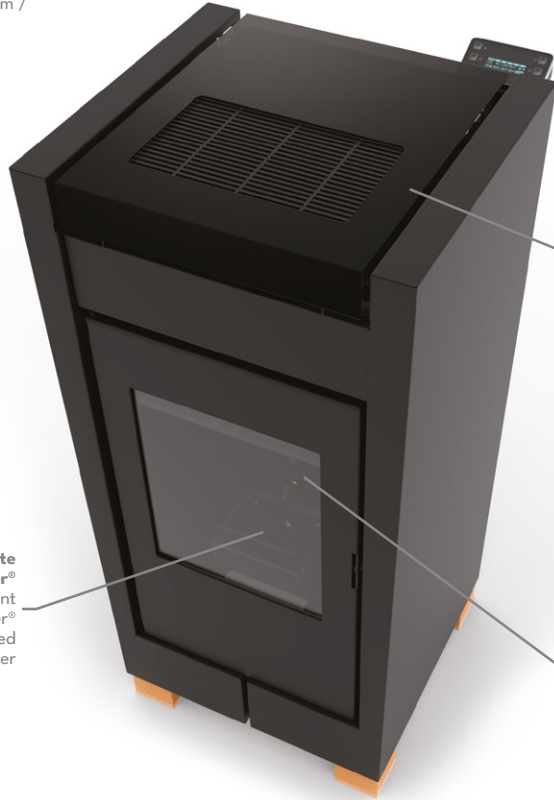

Top in cristallo con funzione Natural a qualsiasi potenza
 Top en cristal avec fonction Natural à tous les niveaux de puissance
 Crystal glass top with Natural function at any power

Bruciatore autopulente brevettato Pelletpower®
 Brûleur autonettoyant breveté Pelletpower®
 Pelletpower® patented self-cleaning burner

Scambiatore a fascio tubiero THERMOCORE®
 Échangeur de chaleur à faisceau tubulaire THERMOCORE®
 pipe heat exchanger

OPTIONAL:



iCONTROL
Sistema wi-fi iControl con web-App
 Système wi-fi iControl avec web-App
 Wi-fi system iControl with web-App
 Wi-Fi System iControl mit web-App
 Sistema wi-fi iControl con web-App



ROOM CONTROL
Termostato ambiente wireless con supporto a muro
 Thermostat d'ambiance wireless avec support mural
 Room wireless Thermostat with its wall support
 Kabelloser Raumthermostat mit Wandhalterung
 Termostato de habitación wireless con su soporte de pared



Tee ridotto per installazione scarico fumi centrale superiore
 Joint en "T" réduit pour sortie centrale supérieure de fumées
 Reduced "T" joint for central upper smoke extraction outlet

Matt black

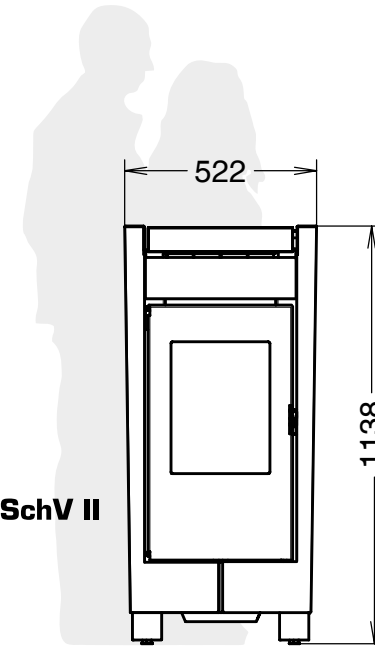

- 84
- mm
- 1138x522x566
- 2,5 - 10,2
- kW NOM. 2,8 - 9,3
- 0,51 - 2,12
- 17,4



CSTB BImSchV II
 le futur en construction

-
-
-
-
-
-
-
-
-
-
-
-
-
-
-
-



plus



KOKKOLA® Evo



ITA Kokkola® risponde al bisogno innato di sentirsi amati e protetti, il fuoco viene accarezzato e diventa il perfetto equilibrio tra calore e comfort. Per tutte le abitazioni di campagna e città, al mare ed in montagna Kokkola® è la stufa a pellet canalizzabile che arreda con eleganza grazie ai delicati colori ed alla qualità della lavorazione. Alcuni ricercati dettagli come l'alternanza dei materiali utilizzati, che vanno dalla ghisa alle pregiate maioliche lavorate a mano, rendono il design di Kokkola® prestigioso e raffinato. La predisposizione per lo scarico fumi centrale e superiore, assieme al pratico accesso al serbatoio attraverso lo scorrimento del coperchio in ghisa danno un tocco di contemporaneità ad uno stile tradizionale.

FRA Le Kokkola® répond au besoin inné de se sentir aimés et protégés ; le feu vous caresse et forme l'équilibre parfait entre chaleur et confort. Pour tous les types d'habitations, à la campagne et en ville, à la mer et en montagne, le Kokkola® est le poêle à granulés canalisable qui meuble avec élégance, grâce à ses couleurs délicates et à la qualité de sa réalisation. Les détails recherchés, comme l'alternance des matériaux utilisés, de la fonte aux précieuses céramiques faites à la main, rendent le design du Kokkola® prestigieux et raffiné. La prédisposition pour la sortie des fumées centrale et supérieure, et l'accès pratique au réservoir à granulés par coulissement du couvercle en fonte, donnent une touche de contemporanéité à un style traditionnel.

ENG Kokkola® satisfies the natural need to feel loved and protected; the dancing flames are the perfect balance of warmth and comfort. For houses in cities or in the countryside, near the sea or in the mountains, Kokkola® is the air-ducting pellet stove that furnishes your home with elegance, having delicate flowers decorations and high quality manufacturing. Some precious details like materials used, from cast iron to precious ceramics handmade by master craftsmen, make the design of Kokkola® very refined and elegant. The predisposition for the top central smoke outlet, together with the innovative cast iron sliding top access to the pellet tank bring a touch of contemporary to the traditional style.

DEU Kokkola® erfüllt das natürliche Bedürfnis von sich geliebt und beschützt zu fühlen; die tanzenden Flammen sind die perfekte Balance von Wärme und Komfort. Egal ob für ein Haus in der Stadt oder auf dem Land, am Meer oder in den Bergen, Kokkola® ist der kanalisierbare Pelletofen, der Ihr Zuhause mit Eleganz, zarter Blumen-Dekoration und hochwertiger Verarbeitung aufwertet. Wertvolle Details aus Gußeisen oder die exklusive handgefertigte Keramik machen das Design von Kokkola® raffiniert und elegant. Die Möglichkeit für eine mittige Rauchrohrführung in Verbindung mit dem innovativen Gußeisen Schiebemechanismus zum Befüllen des Pellettanks bringt einen zusätzlichen Hauch von moderner Technik welcher sich mit dem traditionellen Stil des Ofens verbindet.

ESP Kokkola® responde a la necesidad innata de sentirse queridos y protegidos, el fuego se acaricia y se convierte en el perfecto equilibrio de calor y confort. Para todas las viviendas de campo, en ciudad, al mar y a la montaña, Kokkola® es una estufa de pellets canalizada que decora con elegancia gracias a sus colores delicados y a la alta calidad de fabricación. Algunos detalles sofisticados, como la alternancia de los materiales utilizados, de la fundición hasta las preciosas mayólicas hechas a mano, hacen del diseño de Kokkola® algo prestigioso y refinado. La predisposición a la salida de humos central y superior, junto al cómodo acceso al depósito a través de la tapa retráctil en fundición le dan un toque contemporáneo a su estilo tradicional.

Una canalizzazione posteriore
Un conduit d'air postérieurs
One rear hot air ducting outlet

Uscita fumi centrale o posteriore
Sortie des fumées centrale ou postérieure
Central smoke outlet or rear

Schermo comandi programmabile
Panneau des commandes programmable
Programmable control screen

Coperchio superiore in ghisa con accesso scorrevole per il caricamento del pellet
Couvercle coulissant en fonte pour le chargement des granulés
Cast iron sliding top access to the pellet tank

Maniglia removibile. Essenzialità nel design e maggior sicurezza
Poignée amovible. Design essentiel et sécurité accrue
Removable door handle. Essential design and high safety

L'elegante design rialzato della base facilita la pulizia
L'élégant design rehaussé de la base simplifie l'entretien
The refined raised base facilitates the cleaning operations

Bruciatore in ghisa
Brûleur en fonte
Cast iron burner

OPTIONAL:



iCONTROL
Sistema wi-fi iControl con web-App
Système wi-fi iControl avec web-App
Wi-fi system iControl with web-App
Wi-Fi System iControl mit web-App
Sistema wi-fi iControl con web-App



ROOM CONTROL
Termostato ambiente wireless con supporto a muro
Thermostat d'ambiance wireless avec support mural
Room wireless Thermostat with its wall support
Kabelloser Raumthermostat mit Wandhalterung
Termostato de habitación wireless con su soporte de pared



Tea ridotto per installazione scarico fumi centrale superiore
Joint en "T" réduit pour sortie centrale supérieure de fumées
Reduced "T" joint for central upper smoke extraction outlet

Bianco



Beige



Tortora



Bordeaux

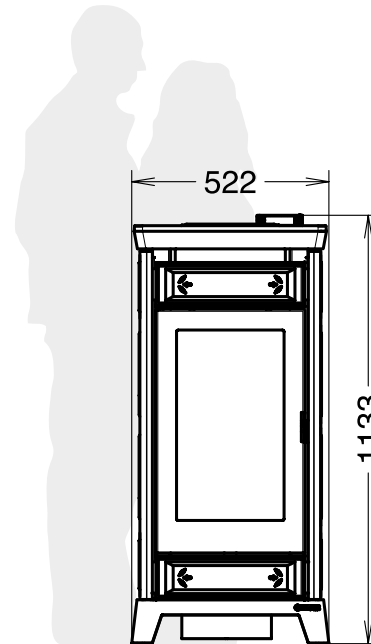

90



1133x522x577



3,3 - 10,9



2,9 - 10,0



0,7 - 2,3



16

Eco DESIGN 2022 **5 STELLE DM 186/7** **7 ÉTOILES** **9 mg/m³ 13% di O₂** **POLVERI** **BlmSchV II**

A+ A++
↑ G



natural plus



FLÅM Evo6

maiolica

ITA Stufa a pellet ermetica e canalizzabile dotata di bruciatore autopulente fino a 500 ore NO-STOP. Fiamma emozionale, funzione Natural a qualsiasi potenza, scambiatore di calore a fascio tubiero, facilità di pulizia ordinaria e straordinaria, predisposizione wi-fi technology.

FRA Poêle à granulés étanche et canalisable, doté de brûleur autonettoyant jusqu'à 500 heures NON-STOP. Flamme émotionnelle, fonction Natural à tous les niveaux de puissance, échangeur de chaleur à faisceau tubulaire, nettoyages ordinaire et extraordinaire faciles, prédisposition à la technologie Wi-Fi.

ENG Hermetically sealed and ductable pellet stove fitted with a self-cleaning burner with up to 500 hours NON-STOP operation. Emotional flame, Natural function at any power, tube heat exchanger, easy routine and extraordinary cleaning, provision for Wi-Fi technology.

DEU Luftdichter und kanalisierbarer Pellettheizofen mit selbstreinigendem Brenner für bis zu 500 Stunden NON-STOP. Angenehmes Flammenbild, Funktion „Natural“ bei jeder Leistung, Rohrbündelwärmetauscher, leichte ordentliche und außerordentliche Reinigung, Wi-Fi-Anschluss möglich.

ESP Estufa de pellets hermética y canalizable, dotada de quemador autolimpiante capaz de funcionar hasta 500 horas NON-STOP. Llama emocional, función Natural a cualquier potencia, intercambiador de calor tubular, facilidad de limpieza ordinaria y extraordinaria, predisposición para tecnología wifi.

Uscite fumi disponibili:
 - superiore centrale integrata Ø80mm
 - posteriore Ø80mm

Sorties des fumées disponibles :
 - central supérieur intégré Ø80mm /
 coaxial Ø125-130mm
 - arrière Ø80mm

Flue outlet options:
 - upper central integrated Ø80mm /
 coaxial Ø125-130mm
 - rear Ø80mm

Una canalizzazione posteriore
 Un conduit d'air postérieurs
 One rear hot air ducting outlet

OPTIONAL:



iCONTROL
Sistema wi-fi iControl con web-App
 Système wi-fi iControl avec web-App
 Wi-fi system iControl with web-App
 Wi-Fi System iControl mit web-App
 Sistema wi-fi iControl con web-App



ROOM CONTROL
Termostato ambiente wireless con supporto a muro
 Thermostat d'ambiance wireless avec support mural
 Room wireless Thermostat with its wall support
 Kabelloser Raumthermostat mit Wandhalterung
 Termostato de habitación wireless con su soporte de pared



Tee ridotto per installazione scarico fumi centrale superiore
 Joint en "T" réduit pour sortie centrale supérieure de fumées
 Reduced "T" joint for central upper smoke extraction outlet

Maiolica



Beige



Bordeaux



Metalcolor



Matt black

Comando per la canalizzazione
 Control for ducting outlet
 Commande de la canalisation

Top in ghisa scorrevole con funzione Natural a qualsiasi potenza
 Top en fonte coulissant avec fonction Natural à tous les niveaux de puissance
 Sliding cast iron top with Natural function at any power

Scambiatore a fascio tubiero THERMOCORE®
 Échangeur de chaleur à faisceau tubulaire THERMOCORE®
 pipe heat exchanger

Bruciatore autopulente brevettato Pelletpower®
 Brûleur autonettoyant breveté Pelletpower®
 Pelletpower® patented self-cleaning burner

L'elegante design rialzato della base facilita la pulizia
 L'élégant design rehaussé de la base simplifie l'entretien
 The refined raised base facilitates the cleaning operations

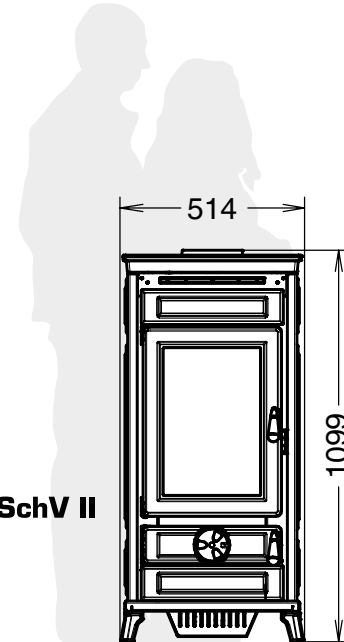

84



mm

1138x514x565



kW

2,5 - 10,2



kW NOM.

2,8 - 9,3



0,51 - 2,12



17,4



CSTB BlmSchV II
 le futur en construction



10mx1

A+ A++
↑
G



natural plus

SlimQuadro Lumia Evo6

metalcolor

ITA Stufa a pellet salvaspazio ermetica, dotata di bruciatore autopulente fino a 500 ore NO-STOP. Canalizzabile con flusso d'aria orientabile, fiamma emozionale, funzione Natural a qualsiasi potenza, scambiatore di calore a fascio tubiero, facilità di pulizia ordinaria e straordinaria, predisposizione wi-fi technology.

FRA Poêle à granulés étanche et peu encombrant, doté de brûleur autonettoyant jusqu'à 500 heures NON-STOP. Canalizable avec flux d'air orientable, flamme émotionnelle, fonction Natural à tous les niveaux de puissance, échangeur de chaleur à faisceau tubulaire, nettoyages ordinaire et extraordinaire faciles, prédisposition à la technologie Wi-Fi.

ENG Hermetically sealed, space-saving pellet stove, fitted with a self-cleaning burner with up to 500 hours NON-STOP operation. Ductable with air flow that can be directed as desired, emotional flame, Natural function at any power, tube heat exchanger, easy routine and extraordinary cleaning, provision for Wi-Fi technology.

DEU Luftdichter, platzsparender Pelletheizofen mit selbstreinigendem Brenner für bis zu 500 Stunden NON-STOP. Kanalisierbar mit orientierbarem Luftstrom, angenehmes Flammenbild, Funktion „Natural“ bei jeder Leistung, Rohrbündelwärmetauscher, leichte ordentliche und außerordentliche Reinigung, Wi-Fi-Anschluss möglich.

ESP Estufa de pellets compacta hermética, dotada de quemador autolimpiante capaz de funcionar hasta 500 horas NON-STOP. Canalizable con flujo de aire orientable, llama emocional, función Natural a cualquier potencia, intercambiador de calor tubular, facilidad de limpieza ordinaria y extraordinaria, predisposición para tecnología wifi.

Multiway Air System, flusso d'aria orientabile:

- frontale, lato destro, lato sinistro
- 2 canalizzazioni superiori o posteriori
- 1 canalizzazione superiore e 1 posteriore
- flusso bilanciato (multi uscite)

Multiway Air System, flux d'air orientable :

- frontal, côté droit, côté gauche
- 2 canalisations supérieures ou postérieures
- 1 canalisation supérieure et 1 postérieure
- flux équilibré (sorties multiples)

Multiway Air System, adjustable airflow:

- front, right side, left side
- 2 upper or rear ducts
- 1 upper and 1 rear duct
- balanced flow (multi-outlets)

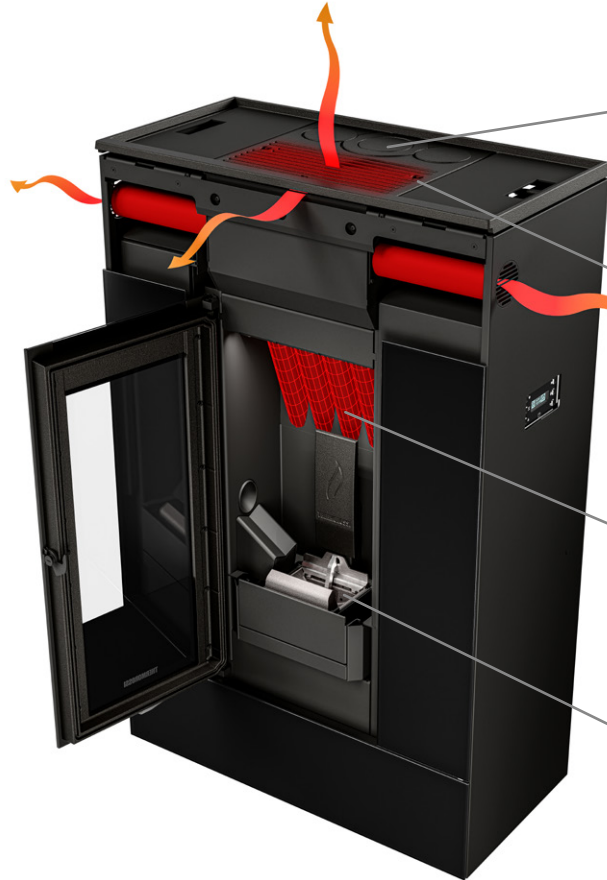

Uscite fumi disponibili:

- superiore centrale integrata Ø80mm
- posteriore Ø80mm

Sorties des fumées disponibles :

- central supérieur intégré Ø80mm / coaxial Ø125-130mm
- arrière Ø80mm

Flue outlet options:

- upper central integrated Ø80mm / coaxial Ø125-130mm
- rear Ø80mm

Top in ghisa con funzione Natural a qualsiasi potenza

Top en fonte avec fonction Natural à tous les niveaux de puissance
Cast iron top with Natural function at any power

Scambiatore a fascio tubiero THERMOCORE®

Échangeur de chaleur à faisceau tubulaire THERMOCORE®
pipe heat exchanger

Bruciatore autopulente brevettato Pelletpower®

Brûleur autonettoyant breveté Pelletpower®
Pelletpower® patented self-cleaning burner

OPTIONAL:



iCONTROL
Sistema wi-fi iControl con web-App
Système wi-fi iControl avec web-App
Wi-fi system iControl with web-App
Wi-Fi System iControl mit web-App
Sistema wi-fi iControl con web-App



ROOM CONTROL
Termostato ambiente wireless con supporto a muro
Thermostat d'ambiance wireless avec support mural
Room wireless Thermostat with its wall support
Kabelloser Raumthermostat mit Wandhalterung
Termostato de habitación wireless con su soporte de pared



Matt Black

Bronze

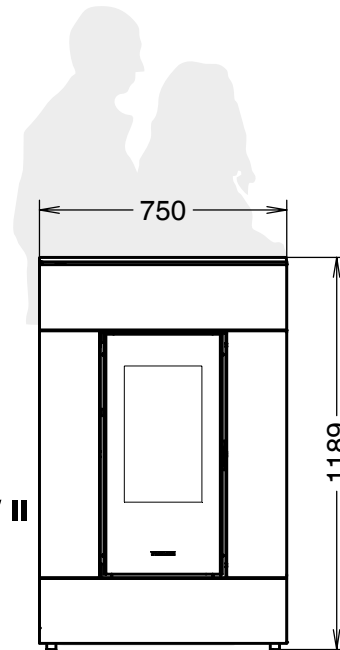

90



1189x750x377



2,9 - 10,7



2,8 - 10



0,6 - 2,2



17



CSTB BlmSchV II
le futur en construction



16mx1
8mx2

A+ A++

natural plus

SlimQuadro Lumia Evo6

cristallo

- ITA Stufa a pellet salvaspazio ermetica, dotata di bruciatore autopulente fino a 500 ore NO-STOP. Canalizzabile con flusso d'aria orientabile, fiamma emozionale, funzione Natural a qualsiasi potenza, scambiatore di calore a fascio tubiero, facilità di pulizia ordinaria e straordinaria, predisposizione wi-fi tecnologia.
- FRA Poêle à granulés étanche et peu encombrant, doté de brûleur autonettoyant jusqu'à 500 heures NON-STOP. Canalizable avec flux d'air orientable, flamme émotionnelle, fonction Natural à tous les niveaux de puissance, échangeur de chaleur à faisceau tubulaire, nettoyages ordinaire et extraordinaire faciles, prédisposition à la technologie Wi-Fi.
- ENG Hermetically sealed, space-saving pellet stove, fitted with a self-cleaning burner with up to 500 hours NON-STOP operation. Ductable with air flow that can be directed as desired, emotional flame, Natural function at any power, tube heat exchanger, easy routine and extraordinary cleaning, provision for Wi-Fi technology.
- DEU Luftdichter, platzsparender Pelletheizofen mit selbstreinigendem Brenner für bis zu 500 Stunden NON-STOP. Kanalisierbar mit orientierbarem Luftstrom, angenehmes Flammenbild, Funktion „Natural“ bei jeder Leistung, Rohrbündelwärmetauscher, leichte ordentliche und außerordentliche Reinigung, Wi-Fi-Anschluss möglich.
- ESP Estufa de pellets compacta hermética, dotada de quemador autolimpiante capaz de funcionar hasta 500 horas NON-STOP. Canalizable con flujo de aire orientable, llama emocional, función Natural a cualquier potencia, intercambiador de calor tubular, facilidad de limpieza ordinaria y extraordinaria, predisposición para tecnología wifi.

Multiway Air System, flusso d'aria orientabile:

- frontale, lato destro, lato sinistro
- 2 canalizzazioni superiori o posteriori
- 1 canalizzazione superiore e 1 posteriore
- flusso bilanciato (multi uscite)

Multiway Air System, flux d'air orientable :

- frontal, côté droit, côté gauche
- 2 canalisations supérieures ou postérieures
- 1 canalisation supérieure et 1 postérieure
- flux équilibré (sorties multiples)

Multiway Air System, adjustable airflow:

- front, right side, left side
- 2 upper or rear ducts
- 1 upper and 1 rear duct
- balanced flow (multi-outlets)

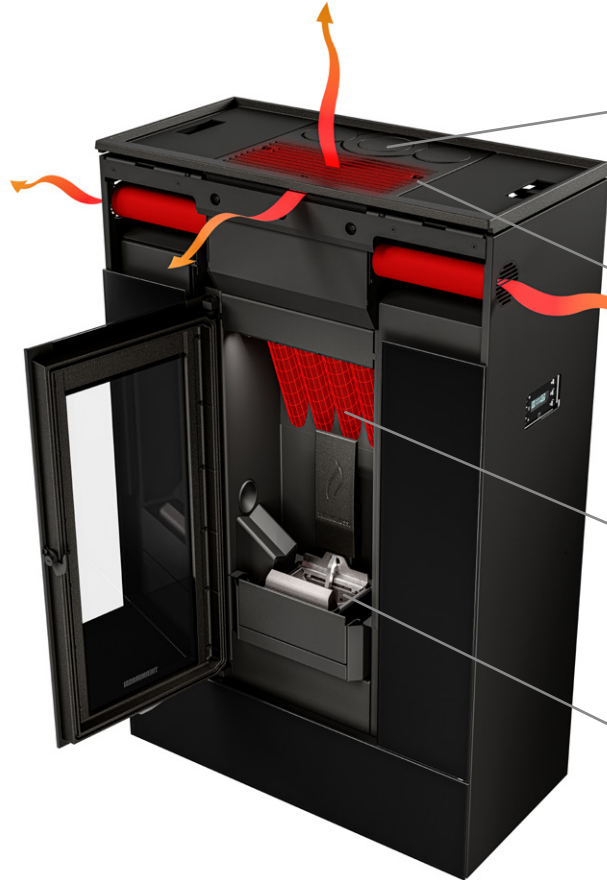

Uscite fumi disponibili:

- superiore centrale integrata Ø80mm
- posteriore Ø80mm

Sorties des fumées disponibles :

- central supérieur intégré Ø80mm / coaxial Ø125-130mm
- arrière Ø80mm

Flue outlet options:

- upper central integrated Ø80mm / coaxial Ø125-130mm
- rear Ø80mm

Top in ghisa con funzione Natural a qualsiasi potenza

Top en fonte avec fonction Natural à tous les niveaux de puissance
Cast iron top with Natural function at any power

Scambiatore a fascio tubiero THERMOCORE®

Échangeur de chaleur à faisceau tubulaire THERMOCORE®
pipe heat exchanger

Bruciatore autopulente brevettato Pelletpower®

Brûleur autonettoyant breveté Pelletpower®
Pelletpower® patented self-cleaning burner

OPTIONAL:



iCONTROL
Sistema wi-fi iControl con web-App
Système wi-fi iControl avec web-App
Wi-fi system iControl with web-App
Wi-Fi System iControl mit web-App
Sistema wi-fi iControl con web-App



ROOM CONTROL
Termostato ambiente wireless con supporto a muro
Thermostat d'ambiance wireless avec support mural
Room wireless Thermostat with its wall support
Kabelloser Raumthermostat mit Wandhalterung
Termostato de habitación wireless con su soporte de pared



Nero

Bianco



Advanced cleaning PELLETPOWER®
bruciatore brevettato

Up to 500 hours NO-STOP

Eco DESIGN 2022

5 STELLE DM 186/7

7 ÉTOILES

POLVERI 7 mg/m³ 13% di O₂

CSTB BlmSchV II
le futur en construction



16mx1
8mx2

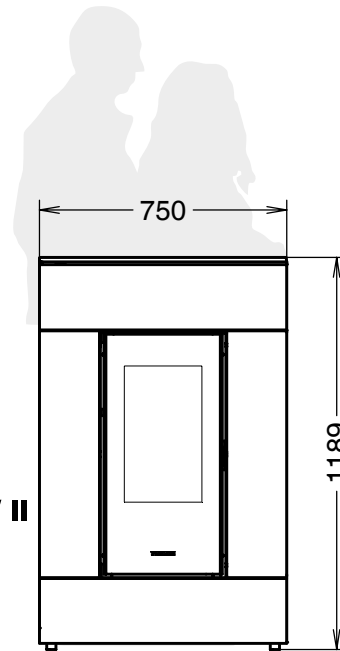

90

1189x750x377

2,9 - 10,7

kW NOM.
2,8 - 10

0,6 - 2,2

17

A+ A++
↑
G



natural plus

SlimQuadro Lumia Evo6

stone

- ITA Stufa a pellet salvaspazio ermetica, dotata di bruciatore autopulente fino a 500 ore NO-STOP. Canalizzabile con flusso d'aria orientabile, fiamma emozionale, funzione Natural a qualsiasi potenza, scambiatore di calore a fascio tubiero, facilità di pulizia ordinaria e straordinaria, predisposizione wi-fi tecnologia.
- FRA Poêle à granulés étanche et peu encombrant, doté de brûleur autonettoyant jusqu'à 500 heures NON-STOP. Canalizable avec flux d'air orientable, flamme émotionnelle, fonction Natural à tous les niveaux de puissance, échangeur de chaleur à faisceau tubulaire, nettoyages ordinaire et extraordinaire faciles, prédisposition à la technologie Wi-Fi.
- ENG Hermetically sealed, space-saving pellet stove, fitted with a self-cleaning burner with up to 500 hours NON-STOP operation. Ductable with air flow that can be directed as desired, emotional flame, Natural function at any power, tube heat exchanger, easy routine and extraordinary cleaning, provision for Wi-Fi technology.
- DEU Luftdichter, platzsparender Pelletheizofen mit selbstreinigendem Brenner für bis zu 500 Stunden NON-STOP. Kanalisierbar mit orientierbarem Luftstrom, angenehmes Flammenbild, Funktion „Natural“ bei jeder Leistung, Rohrbündelwärmetauscher, leichte ordentliche und außerordentliche Reinigung, Wi-Fi-Anschluss möglich.
- ESP Estufa de pellets compacta hermética, dotada de quemador autolimpiante capaz de funcionar hasta 500 horas NON-STOP. Canalizable con flujo de aire orientable, llama emocional, función Natural a cualquier potencia, intercambiador de calor tubular, facilidad de limpieza ordinaria y extraordinaria, predisposición para tecnología wifi.

**Multiway Air System,
flusso d'aria orientabile:**

- frontale, lato destro, lato sinistro
- 2 canalizzazioni superiori o posteriori
- 1 canalizzazione superiore e 1 posteriore
- flusso bilanciato (multi uscite)

**Multiway Air System,
flux d'air orientable :**

- frontal, côté droit, côté gauche
- 2 canalisations supérieures ou postérieures
- 1 canalisation supérieure et 1 postérieure
- flux équilibré (sorties multiples)

**Multiway Air System,
adjustable airflow:**

- front, right side, left side
- 2 upper or rear ducts
- 1 upper and 1 rear duct
- balanced flow (multi-outlets)

Uscite fumi disponibili:

- superiore centrale integrata Ø80mm
- posteriore Ø80mm

Sorties des fumées disponibles :

- central supérieur intégré Ø80mm / coaxial Ø125-130mm
- arrière Ø80mm

Flue outlet options:

- upper central integrated Ø80mm / coaxial Ø125-130mm
- rear Ø80mm

Top in ghisa con funzione Natural a qualsiasi potenza

Top en fonte avec fonction Natural à tous les niveaux de puissance
Cast iron top with Natural function at any power

Scambiatore a fascio tubiero THERMOCORE®

Échangeur de chaleur à faisceau tubulaire THERMOCORE®
pipe heat exchanger

Bruciatore autopulente brevettato Pelletpower®

Brûleur autonettoyant breveté Pelletpower®
Pelletpower® patented self-cleaning burner

OPTIONAL:



iCONTROL

Sistema wi-fi iControl con web-App
Système wi-fi iControl avec web-App
Wi-fi system iControl with web-App
Wi-Fi System iControl mit web-App
Sistema wi-fi iControl con web-App



ROOM CONTROL

Termostato ambiente wireless con supporto a muro

Thermostat d'ambiance wireless avec support mural
Room wireless Thermostat with its wall support
Kabelloser Raumthermostat mit Wandhalterung
Termostato de habitación wireless con su soporte de pared

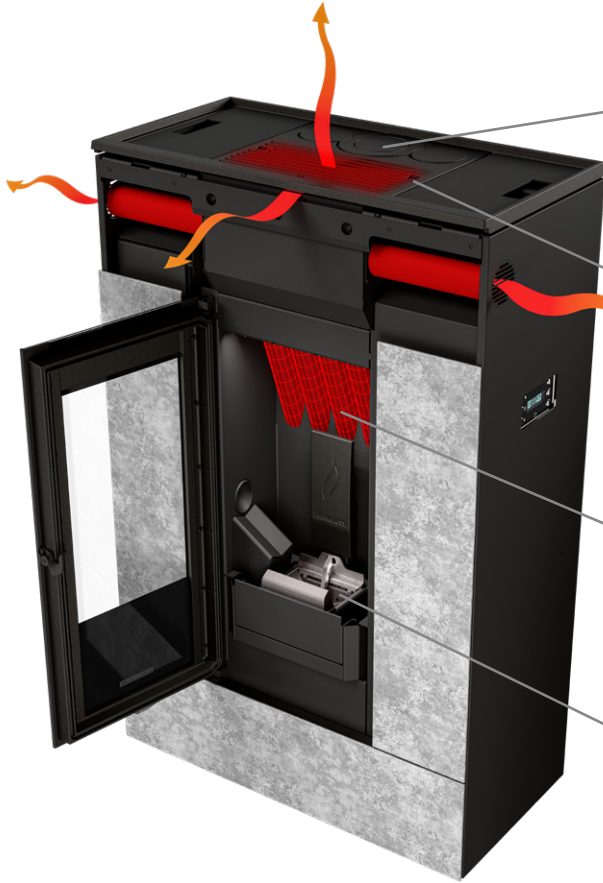

**Advanced cleaning
PELLETPower®**
bruciatore brevettato

**Up to
500 hours
NO-STOP**

**Eco
DESIGN
2022**

**5
STELLE
DM 186/7**

**7
ÉTOILES**

**POLVERI
7
mg/m³
13% di O₂**

CSTB BlmSchV II
le futur en construction



16mx1
8mx2

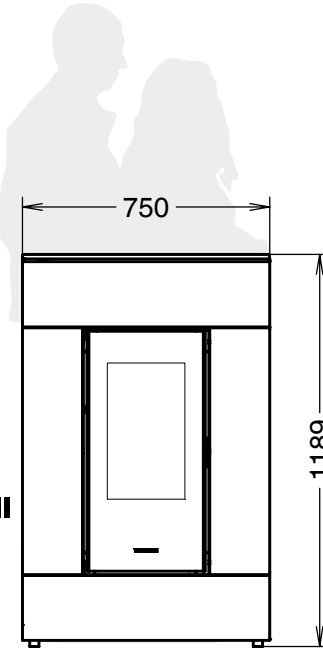

90
mm
1189x750x377
2,9 - 10,7
kW
kW
NOM.
2,8 - 10
0,6 - 2,2



Gres



Stone



plus

SlimQuadro11

Evo6 cristallo

- ITA Thermorossi cambia i confini tra spazi e funzioni, la stufa diventa un "mobile" da inserire in assoluta libertà, un quadro da appendere dall'esclusivo design brevettato. Dotata di scambiatore di calore THERMOCORE® e pulizia ordinaria e straordinaria semplificata EASY CLEANING, disponibile in cristallo colorato in tinta unita oppure nelle versioni Moondecor e Sundecor.
- FRA Thermorossi modifie les frontières entre espaces et fonctions, le poêle devient un tableau à accrocher, un "meuble" à insérer en toute liberté. Doté de l'échangeur de chaleur THERMOCORE® et du système de nettoyage ordinaire et extraordinaire simplifié EASY CLEANING. Disponible avec cristal coloré, uni ou dans les versions Moondecor et Sundecor.
- ENG Thermorossi moves the borders between space and function. The heater becomes a masterpiece to be exhibited, a "piece of furniture" to be placed at will, a picture to be hanged. Equipped with heat exchanger THERMOCORE® and simplified cleaning system EASY CLEANING. Available in coloured glass or with versions Moondecor or Sundecor.
- DEU Thermorossi verändert die Grenzen zwischen Raum und Funktion, wird die Heizung ein "Möbel" am Wille, ein Bild zu hängen platzient werden. Ausgestattet mit dem Wärmetauscher THERMOCORE® und dem einfachen EASY CLEANING Reinigungssystem. Verfügbar in farbigem Frontglas sowie in den Versionen Moondecor oder Sundecor.
- ESP Thermorossi cambia las fronteras entre espacios y funciones, la estufa se convierte en un cuadro para colgar, un "mueble" para combinar libremente. Equipada con intercambiador de calor THERMOCORE® y limpieza ordinaria y extraordinaria simplificadas EASY CLEANING. Disponible en la versión de cristal de color uniforme o en los nuevos Moondecor y Sundecor.

Uscite fumi disponibili:
superiore - posteriore - laterale sinistro
 Sorties des fumées disponibles :
 supérieure - postérieure - latérale gauche
 Flue outlet options: top - rear - left side

Uscite per canalizzazione disponibili: 2 posteriori
1 lato sinistro
 Sorties de canalisation disponibles :
 2 arrières - 1 côté gauche
 Duct vents options:
 2 rear - 1 side right - 1 side left

OPTIONAL:



iCONTROL
Sistema wi-fi iControl con web-App
 Système wi-fi iControl avec web-App
 Wi-fi system iControl with web-App
 Wi-Fi System iControl mit web-App
 Sistema wi-fi iControl con web-App



ROOM CONTROL
Termostato ambiente wireless con supporto a muro
 Thermostat d'ambiance wireless avec support mural
 Room wireless Thermostat with its wall support
 Kabelloser Raumthermostat mit Wandhalterung
 Termostato de habitación wireless con su soporte de pared

Multyway Air System: flusso aria orientabile (fronte - retro - destro - sinistro)

Multyway Air System : flux d'air orientable (avant - arrière - droite - gauche)
 Multyway Air System: adjustable air flow (front - rear - right - left)



Maniglia removibile. Essenzialità nel design e maggior sicurezza
 Poignée amovible.
 Design essentiel et sécurité accrue
 Removable door handle.
 Essential design and high safety

Finitura in cristallo
 Cristal finition
 Crystal finish

Preziosa porta focolare in cristallo e ghisa
 Porte de foyer en fonte et cristal imprimé en sérigraphie
 Precious cast iron and glass firebox door

Piedistallo removibile per installazione sospesa a muro
 Pied amovible pour l'installation murale
 Removable pedestal for wall-installation



Schermo comandi programmabile
 Panneau des commandes programmable
 Programmable control screen

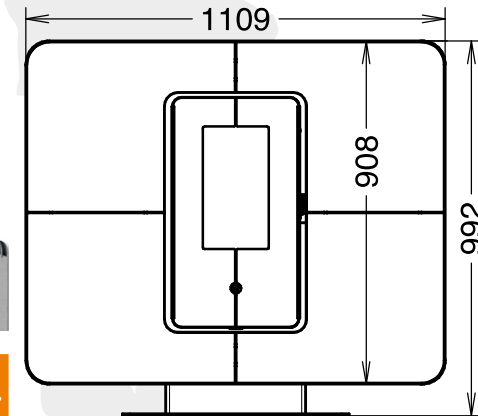

Eco DESIGN 2022

5 STELLE
DM 186/7

7 ÉTOILES

POLVERI 9 mg/m³ 13% di O₂

CSTB BlmSchV II
 le futur en construction



Icons representing features: SETUP OK, Easy Cleaning, THERMO CORE™, 4 YEARS, chrono, XXL, 36 decibel, AIR FILTER NO DUST, MULTWAY AIR SYSTEM, mechanical safety devices, ETANCHE (HERMETIC), EXTERNAL PRIMARY AIR INLET, Wi-Fi Technology, and a map of Italy.

16m¹
8m²

Cristallo

Bianco

Bordeaux

Nero

Cristallo Decor

Sundecor

Moondecor



96



992x1109x318



3,1 - 11,1



2,8 - 10,3



0,66 - 2,3



18

A+ A++
↑
G



plus

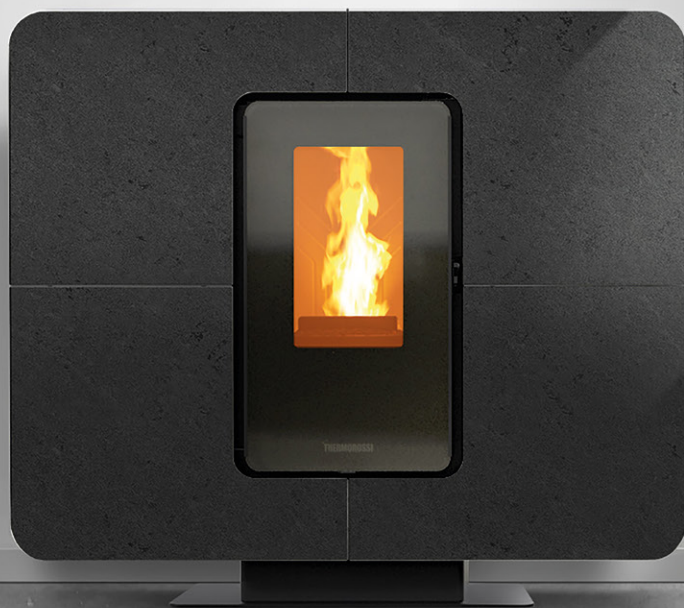

SlimQuadro11

Evo6 gres

ITA Spesso imitata ma mai raggiunta, Slimquadro 11 si rinnova e diventa ancora più bella grazie al nuovo design con i comandi superiori a scomparsa, la soluzione ideale per riscaldare la tua casa con il minimo ingombro.

FRA Souvent imité mais jamais égalé, le Slimquadro 11 se renouvelle et devient encore plus beau, grâce au nouveau design avec commandes supérieures cachées. La solution idéale pour chauffer la maison avec un encombrement minimum.

ENG Often imitated but never reached, Slimquadro 11 renews itself and becomes even more beautiful thanks to the new design with concealed top controls, the ideal solution to heat your home in the smallest space.

DEU Oft imitiert, aber nie erreicht, erneuert sich der Slimquadro 11 und wird noch schöner dank des neuen Designs mit verdeckten Bedienelementen oben, um Ihr Haus auf kleinstem Raum zu beheizen.

ESP A menudo imitada pero nunca alcanzada, Slimquadro 11 se renueva y se vuelve aún más hermosa, gracias al nuevo diseño con controles superiores ocultos. La solución ideal para calentar la casa en el menor espacio.

Uscite fumi disponibili:
superiore - posteriore - laterale sinistro
 Sorties des fumées disponibles :
 supérieure - postérieure - latérale gauche
 Flue outlet options: top - rear - left side

Uscite per canalizzazione disponibili: **2 posteriori**
1 lato sinistro
 Sorties de canalisation disponibles :
 2 arrières - 1 côté gauche
 Duct vents options:
 2 rear - 1 side right - 1 side left

OPTIONAL:



iCONTROL
Sistema wi-fi iControl con web-App
 Système wi-fi iControl avec web-App
 Wi-fi system iControl with web-App
 Wi-Fi System iControl mit web-App
 Sistema wi-fi iControl con web-App



ROOM CONTROL
Termostato ambiente wireless con supporto a muro
 Thermostat d'ambiance wireless avec support mural
 Room wireless Thermostat with its wall support
 Kabelloser Raumthermostat mit Wandhalterung
 Termostato de habitación wireless con su soporte de pared

Multyway Air System: flusso aria orientabile (fronte - retro - destro - sinistro)
 Multyway Air System : flux d'air orientable (avant - arrière - droite - gauche)
 Multyway Air System: adjustable air flow (front - rear - right - left)



Maniglia removibile. Essenzialità nel design e maggior sicurezza
 Poignée amovible.
 Design essentiel et sécurité accrue
 Removable door handle.
 Essential design and high safety

Finitura in gres porcellanato
 Finition en céramique matte
 Porcelain stoneware finish



Schermo comandi programmabile
 Panneau des commandes programmable
 Programmable control screen

Preziosa porta focolare in cristallo e ghisa
 Porte de foyer en fonte et cristal imprimé en sérigraphie
 Precious cast iron and glass firebox door

Piedistallo removibile per installazione sospesa a muro
 Pied amovible pour l'installation murale
 Removable pedestal for wall-installation

Eco DESIGN 2022 **5 STELLE DM 186/7** **7 ÉTOILES** **POLVERI 9 mg/m³ 13% di O₂**

CSTB BImSchV II
 le futur en construction



16m^x1
8m^x2

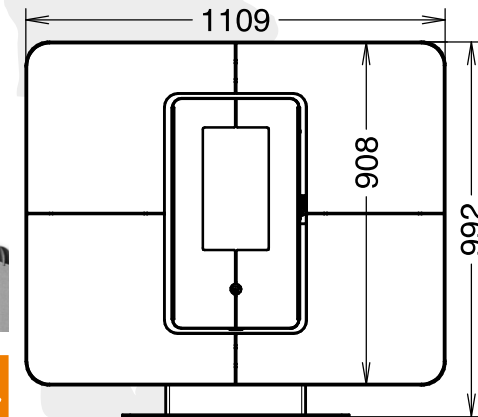

- Gres
- Bianco opaco
- Stone
- Terra
- Grafite



idra

SlimQuadro

Idra Evo cristallo



ITA Thermorossi cambia i confini tra spazi e funzioni, la stufa diventa un "mobile" da inserire in assoluta libertà, un quadro da appendere dall'esclusivo design brevettato. Dotata di scambiatore di calore THERMOCORE® e pulizia ordinaria e straordinaria semplificata EASY CLEANING. La versione Idra è dotata di bruciatore motorizzato con tecnologia PELLETPOWER®.

FRA Thermorossi modifie les frontières entre espaces et fonctions : le poêle devient un tableau à accrocher au mur, au design exclusif et breveté, un "meuble" à insérer en toute liberté. Doté de l'échangeur de chaleur THERMOCORE® et du système de nettoyage ordinaire et extraordinaire simplifié EASY CLEANING. Version Idra équipée du brûleur motorisé avec technologie PELLETPOWER®.

ENG Thermorossi moves the borders between space and function. The heater becomes a masterpiece to be exhibited, a "piece of furniture" to be placed at will, a picture to be hung. Equipped with heat exchanger THERMOCORE® and simplified cleaning system EASY CLEANING. The version Idra is equipped with the PELLETPOWER® technology patented burner.

DEU Thermorossi verändert die Grenzen zwischen Raum und Funktion, hier wird die Heizung zu einem "Möbelstück" und kann wie ein Bild zu hängend plziert werden. Ausgestattet mit dem Wärmetauscher THERMOCORE® und dem einfachen EASY CLEANING. Version Idra ist mit dem PELLETPOWER® Patentierter Brenner ausgestattet.

ESP Estufa de pellet canalizable Slimquadro 11: Thermorossi cambia las fronteras entre espacios y funciones, la estufa se convierte en un cuadro para colgar, un "mueble" para combinar libremente. Equipada con intercambiador de calor THERMOCORE® y limpieza ordinaria y extraordinaria simplificadas EASY CLEANING. Versión Idra es equipada con la tecnología de quemador motorizado PELLETPOWER®.

Uscite fumi disponibili:
superiore - posteriore - laterale sinistro
 Sorties des fumées disponibles :
 supérieure - postérieure - latérale gauche
 Flue outlet options: top - rear - left side

Finitura in cristallo
 Finition cristal
 Crystal finish

Maniglia removibile.
Essenzialità nel design
e maggior sicurezza
 Poignée amovible.
 Design essentiel
 et sécurité accrue
 Removable door handle.
 Essential design
 and high safety



Preziosa porta focolare
in cristallo e ghisa
 Porte de foyer
 en fonte et cristal
 imprimé en sérigraphie
 Precious cast iron
 and glass firebox door

Buciatore brevettato
PelletPower®
 Brûleur breveté
 PelletPower®
 PelletPower®
 patented burner

Schermo comandi programmabile
 Panneau des commandes
 programmable
 PelletPower®
 Programmable control screen

OPTIONAL:



INTEGRA TR-PACK
 Thermocell® (250/400/500 lt)
 Thermopuffer (400/500/1500 lt)
 Thermosole® (2.0)



Valvola termostatica a 3 vie 1" FFF 55 OT
 Thermostatic valve 3 ways 1" FFF 55 OT
 Vanne thermostatique 3 voies 1" FFF 55 OT

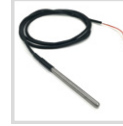

Sonda PT100 (min 2 pz)
per funzione «THERMOCONTROL»
 Thermostat d'ambiance PT100 sensor (min 2 pc)
 for «THERMOCONTROL» function
 Sonde PT100 (min 2 pces)
 pour fonction «THERMOCONTROL»



Cristallo

Bianco

Bordeaux

Nero

Cristallo
Decor

Sundecor

Moondecor

Gres

Bianco
opaco

Grafite

Stone

Terra

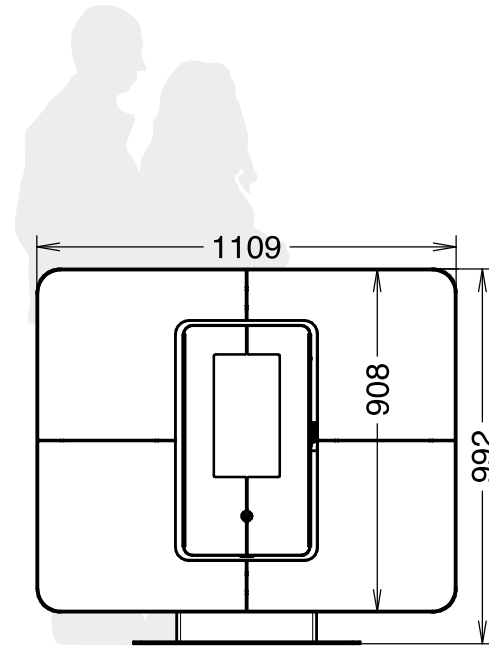

120



992x1109x316



5,3 - 14,0



5,0 - 13,0



1,1 - 3,0



4,3 - 11,8



18

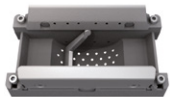

Advanced cleaning
PELLETPOWER®
 bruciatore brevettato



POLVERI
7
 mg/m³
 13% di O₂

BImSchV II



A+ A++



idra

SlimQuadro

Idra Maxi Evo



ITA La collezione Slimquadro® dall'esclusivo design brevettato salva spazio dal successo internazionale, si arricchisce nella versione idra con un nuovo modello ancora più potente. Ideale per il riscaldamento domestico diventa il cuore dell'impianto, facilmente integrabile grazie alle misure compatte. L'innovativo bruciatore motorizzato con tecnologia brevettata PELLETPOWER® mantiene la resa termica elevata e costante nell'arco dell'intera giornata: mantenere il bruciatore pulito significa ridurre sia la manutenzione ordinaria che i costi di combustibile, con un rapido ammortamento del generatore.

FRA La collection Slimquadro®, au design à encombrement réduit exclusif et breveté, forte de son succès international, s'enrichit dans sa version Idra d'un nouveau modèle encore plus puissant. Idéal pour le chauffage domestique, il devient le cœur du circuit, facilement intégrable grâce à ses mesures compactes. L'innovant brûleur motorisé avec technologie brevetée PELLETPOWER® maintient le rendement thermique élevé et constant tout au long du jour : garder le brûleur propre signifie réduire aussi bien la manutention ordinaire que les frais de combustible, avec un amortissement plus rapide du générateur.

ENG The Slimquadro® collection, the innovative space - saving patented design, made exclusively by Thermorossi and which is achieving great international success, enhances itself with a new entry: a new idra model, even more powerful. If you would like to heat a domestic environment through a pellet-heating generator, it provides the ideal solution. It becomes the core of the system, easy to be integrated in living zones thanks to its compact dimensions. The PELLETPOWER® innovative patented burner maintains the correct rate of oxygen keeping the efficiency of combustion stable for longer periods: keeping the burner clean means reducing cleaning times and fuel costs, and payback initial heating-generator costs over few years.

DEU Die Slimquadro® Kollektion, die innovative platzsparende Produktfamilie mit patentiertem Design welche ausschließlich von Thermorossi mit großem internationalen Erfolg hergestellt wird, wird nun mit einem neuen wassergeführten Modell erweitert, welches noch leistungsfähiger ist. Wenn Sie eine größere Fläche durch eine Pellet-Heizung erwärmen möchten, bietet dieses Produkt die ideale Lösung. Es bildet den Kern des Heizsystems welches dank seiner kompakten Abmessungen einfach im Wohnbereich integriert werden kann. PELLETPOWER® das innovative patentierte Brennersystem hält den Sauerstoffgehalt bei der Verbrennung konstant und hält die Effizienz der Verbrennung für einen langen Zeitraum stabil. Der Brenner wird konstant saubergehalten und somit reduzieren sich die Brennstoffkosten und die Amortisation des Heizgerätes über viele Jahre.

ESP La gama Slimquadro® de diseño exclusivo, patentado y ahorra-espacio de éxito internacional, se enriquece en la versión idra con un nuevo modelo, aún más potente. Ideal para la calefacción del hogar, se convierte en el centro de la instalación integrándose fácilmente gracias a sus medidas compactas. El quemador motorizado con tecnología patentada PELLETPOWER® mantiene constantemente una alta eficiencia térmica durante todo el día: mantener limpio el quemador quiere decir reducir tanto el mantenimiento como los gastos de combustible, con una rápida amortización del generador.

Uscite fumi disponibili:
superiore - posteriore - laterale sinistro
 Sorties des fumées disponibles :
 supérieure - postérieure - latérale gauche
 Flue outlet options: top - rear - left side

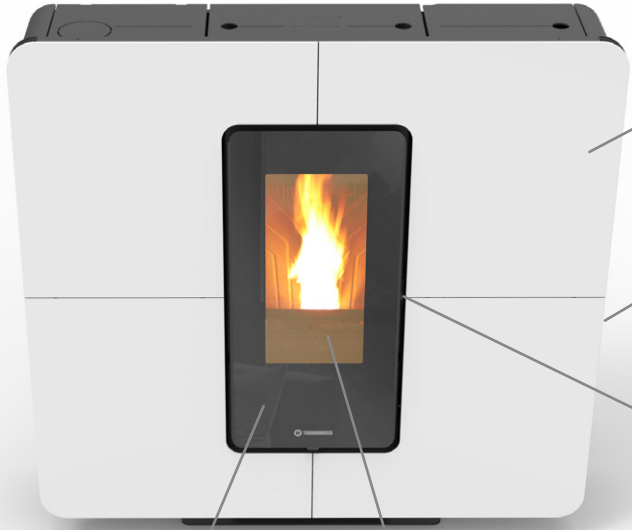

Finitura in cristallo
 Finition cristal
 Crystal finish

Schermo comandi programmabile
 Panneau des commandes
 programmable
 Programmable control screen

Maniglia removibile.
Essenzialità nel design
e maggior sicurezza
 Poignée amovible.
 Design essentiel
 et sécurité accrue
 Removable door handle.
 Essential design
 and high safety

Preziosa porta focolare
in cristallo e ghisa
 Porte de foyer
 en fonte et cristal
 imprimé en sérigraphie
 Precious cast iron
 and glass firebox door

Bruciatore brevettato
PelletPower®
 Brûleur breveté
 PelletPower®
 PelletPower®
 patented burner

OPTIONAL:



INTEGRA TR-PACK
 Thermocell® (250/400/500 lt)
 Thermopuffer (400/500/1500 lt)
 Thermosole® (2.0)



Valvola termostatica a 3 vie 1" FFF 55 OT
 Thermostatic valve 3 ways 1" FFF 55 OT
 Vanne thermostatique 3 voies 1" FFF 55 OT

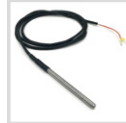

Sonda PT100 (min 2 pz)
per funzione «THERMOCONTROL»
 Thermostat d'ambiance PT100 sensor (min 2 pc)
 for «THERMOCONTROL» function
 Sonde PT100 (min 2 pces)
 pour fonction «THERMOCONTROL»

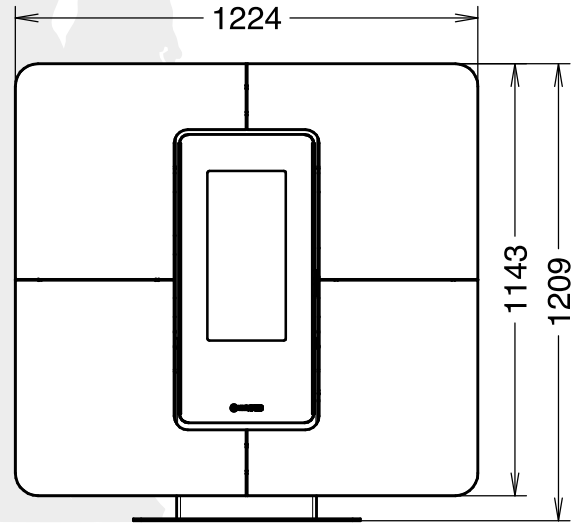
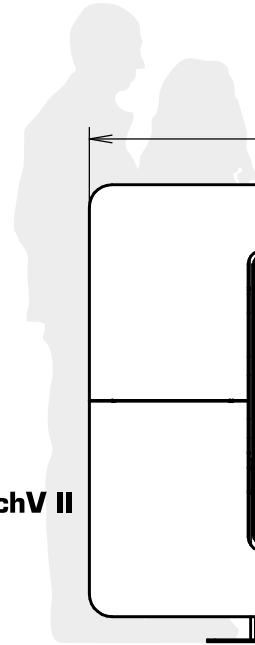

- 185
- mm
- 1209x1224x316
- 6 - 22,7
- 5,8 - 21,3
- 4,2 - 17,7
- 1,2 - 4,7
- 27



Advanced cleaning
PELLETPOWER®
 bruciatore brevettato



POLVERI
7
 mg/m³
 13% di O₂

BlmSchV II

-
- SETUP OK
- Easy Cleaning
- 4 YEARS
- 4 YEARS
- chron
- XXL
- 36 decibel
-
-
- mechanical safety devices
- EXTERNAL
- primary AIR
-



plus

BellaVista™ R3 plus

ITA Innovare è rendere semplice un'operazione complessa. Comfort è migliorare la qualità di vita in casa. Sicurezza è prendersi cura dell'ambiente e di chi utilizza i nostri prodotti. Design è lo studio di forme e soluzioni tecnologiche in grado di anticipare i tempi. La ricerca è riunire tutto questo in un solo progetto. Progettata partendo da un nuovo punto di vista il vostro.

FRA L'Innovation, c'est rendre simple une opération complexe. Le Confort, c'est améliorer la qualité de vie à la maison. La Sécurité, c'est prendre soin du milieu et de qui utilise nos produits. Le Design, c'est l'étude de formes et solutions technologiques qui nous permettent d'être en avance sur notre temps. La Recherche, c'est réunir tout ceci en un seul projet. Projetée à partir d'un nouveau point de vue : le vôtre.

ENG Innovation: it means to simplify an operation hard to do. Comfort: it is the way to improve the quality of living in the home. Safety: it means to take care of the environment and those who use our products. Design: it means to study the form and technological solutions to ensure we are always one-step ahead. Research and Development: it means to take all this and combine together in one unique project. Look far. Designed from a new point of view: yours.

DEU Innovativ bedeutet: Herausforderungen einfach zu lösen. Komfort bedeutet: Lebensqualität zu verbessern. Sicherheit bedeutet: Die Umwelt und die Nutzer des Produktes zu schützen. Design bedeutet: Form und technische Lösungen, die richtungsweisend sind. Forschung und Entwicklung: Verbindet all diese Punkte in einem einzigartigen Projekt. Er wurde entwickelt für einen völlig neuen Blickwinkel: Ihren Blickwinkel.

ESP Innovar quiere decir simplificar una operación compleja. El Comfort es para mejorar la calidad de vida en el hogar. La Seguridad es el cuidado del medio ambiente y de los que utilizan nuestros productos. El Design es el estudio de formas y soluciones tecnológicas que anticipan a los tiempos. La Investigación es reunir todo esto en un solo proyecto. Thermorossi presenta BellaVista™, la primera estufa de pellets con cristal panorámico que ofrece una intrigante visión a 270° grados de la llama, diseñada a partir de un nuevo punto de vista: el vuestro.

Uscite per canalizzazione disponibili: due posteriori*
Sorties de canalisation disponibles : 2 arrières*
Available ducting outlets: two rear*

Scarico fumi superiore
Sortie des fumées
supérieure
Superior smoke exhaust

Piano igienico,
in cristallo con funzione
di scalda vivande
Chauffe-plats
hygiénique, en cristal
Practical food warming
plate in hygienic glass

Scambiatore di calore
brevettato con tecnologia
Thermocore®
Echangeur de chaleur breveté
avec technologie Thermocore®
Patented heat exchanger
with Thermocore® technology

Focolare con visione
del fuoco a 270°
Vision du feu à 270°
Firebox with 270° fire view

Maniglia removibile.
Essenzialità nel design
e maggior sicurezza
Poignée amovible.
Design essentiel
et sécurité accrue
Removable door handle.
Essential design
and high safety

Bruciatore brevettato
PelletPower®
Brûleur breveté
Pellet Power®
PelletPower®
patented burner

Finitura con pietre
decorative
Finition avec des
pierres décoratives
Finishing with
decorative stones

OPTIONAL:



iCONTROL
Sistema wi-fi iControl con web-App
Système wi-fi iControl avec web-App
Wi-fi system iControl with web-App
Wi-Fi System iControl mit web-App
Sistema wi-fi iControl con web-App



ROOM CONTROL
Termostato ambiente wireless con supporto a muro
Thermostat d'ambiance wireless avec support mural
Room wireless Thermostat with its wall support
Kabelloser Raumthermostat mit Wandhalterung
Termostato de habitación wireless con su soporte de pared



Pietre decorative di colore bianco Carrara o nero ardesia
Pierres décoratives couleur blanc mat (Carrare)
ou noir mat (ardoise)
Decorative stone in Carrara white or in slate black colours

Matt
black

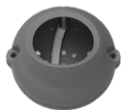
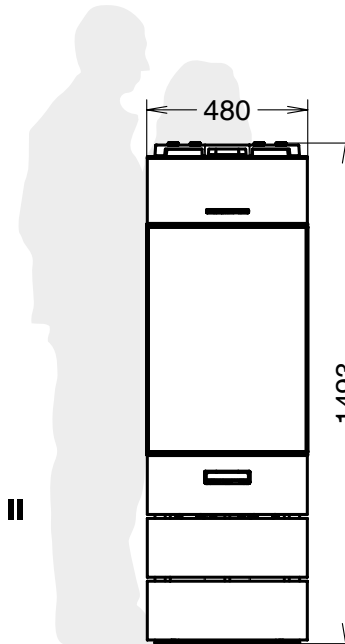

Advanced cleaning
PELLETPOWER®
bruciatore brevettato

Up to
500 hours
NO-STOP

Eco
DESIGN
2022

5
STELLE
DM 186/7

7
ÉTOILES

POLVERI
9
mg/m³
13% di O₂

BlmSchV II



* Con AIRBOX3 installato (opt) - Avec AIRBOX3 installée (opt) - With AIRBOX3 installed (opt)



plus

BellaVista™ S3 plus

ITA Thermorossi dimostra continuamente la propria attenzione a percorrere nuove vie, con tecniche innovative e un design straordinario in grado di aprire nuovi segmenti di mercato. BellaVista Square: stufa a pellet dal design unico ed inconfondibile, ideale come soluzione a penisola per separare due ambienti grazie al vetro panoramico che garantisce una visione del fuoco a 270°.

FRA Thermorossi démontre continuellement son engagement à parcourir de nouvelles voies, avec des techniques innovantes et un design extraordinaire capables d'ouvrir de nouveaux segments de marché. Le BellaVista Square, poêle à granulés au design caractéristique et unique, est la solution idéale comme îlot pour séparer deux pièces, grâce à sa vitre panoramique qui garantit la vision du feu à 270°.

ENG Thermorossi assures its constant and continuous attention to pursue new paths, ever innovative, improved technical solutions and outstanding design, in order to open up new segments of the market. BellaVista Square: pellet stove with a unique and unmistakable design, ideal as a peninsula solution to separate two rooms thanks to the panoramic glass that guarantees a 270° view of the fire.

DEU Thermorossi strebt stets und konstant neue Wege an, um immer innovativere und technisch bessere Lösungen mit herausragendem Design anbieten zu können, wodurch neue Marktsegmente erschlossen werden können. BellaVista Square: Pelletofen mit einzigartigem und unverwechselbarem Design, ideal als Halbinsel-Lösung zur Trennung von zwei Räumen dank der Panoramaverglasung, die eine 270° Sicht auf das Feuer garantiert.

ESP Thermorossi demuestra continuamente su atención a nuevos enfoques, con técnicas innovadoras y un diseño único que puede abrir nuevos segmentos de mercado. BellaVista Square: estufa de pellets de diseño único e inconfundible, ideal como solución peninsular para separar dos habitaciones gracias al vidrio panorámico que garantiza una visión del fuego de 270°.

Uscite per canalizzazione disponibili: due posteriori*
 Sorties de canalisation disponibles : 2 arrières*
 Available ducting outlets: two rear*

Scarico fumi superiore
 Sortie des fumées supérieure
 Superior smoke exhaust

Piano igienico, in cristallo con funzione di scaldia vivande
 Chauffe-plats hygiénique, en cristal
 Practical food warming plate in hygienic glass

Scambiatore di calore brevettato con tecnologia Thermocore®
 Echangeur de chaleur breveté avec technologie Thermocore®
 Patented heat exchanger with Thermocore® technology

Focolare con visione del fuoco a 270°
 Vision du feu à 270°
 Firebox with 270° fire view

Maniglia removibile. Essenzialità nel design e maggior sicurezza
 Poignée amovible. Design essentiel et sécurité accrue
 Removable door handle. Essential design and high safety

Bruciatore brevettato PelletPower®
 Brûleur breveté Pellet Power®
 PelletPower® patented burner

Finitura con pietre decorative
 Finition avec des pierres décoratives
 Finishing with decorative stones

OPTIONAL:



iCONTROL
Sistema wi-fi iControl con web-App
 Système wi-fi iControl avec web-App
 Wi-fi system iControl with web-App
 Wi-Fi System iControl mit web-App
 Sistema wi-fi iControl con web-App



ROOM CONTROL
Termostato ambiente wireless con supporto a muro
 Thermostat d'ambiance wireless avec support mural
 Room wireless Thermostat with its wall support
 Kabelloser Raumthermostat mit Wandhalterung
 Termostato de habitación wireless con su soporte de pared



Pietre decorative di colore bianco Carrara o nero ardesia
 Pierres décoratives couleur blanc mat (Carrare)
 ou noir mat (ardoise)
 Decorative stone in Carrara white or in slate black colours

Matt black

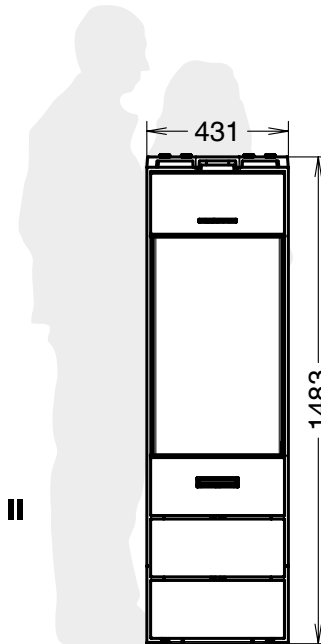

- 98*
- mm
- 1493x481x694
- 3,5 - 11,7*
- kW NOM. 3,3 - 10,9*
- 0,7 - 2,4
- 25

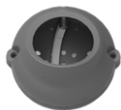

Advanced cleaning
PELLETPower®
 bruciatore brevettato

Up to
500 hours
NO-STOP

Eco
 DESIGN
 2022

5
STELLE
 DM 186/7

7
ÉTOILES

POLVERI
9
 mg/m³
 13% di O₂

BlmSchV II



* Con AIRBOX3 installato (opt) - Avec AIRBOX3 installée (opt) - With AIRBOX3 installed (opt)



A+ A++



6kW - 8kW air

POP Evo

ITA Siete amanti della musica e sognate un look glamour? Ecco a Voi Pop: la stufa a pellet in soli 46 cm di diametro, fatevi conquistare dalla sua personalità e dai preziosi dettagli che la rendono irresistibilmente attraente. Perfetta per una collocazione ad angolo, grazie all'uscita fumi centrale in asse con la stufa. Top in ghisa e fianchi in acciaio. Disponibile anche in versione ermetica.

FRA Vous êtes amateurs de la musique et vous rêvez d'un look glamour ? Pour vous, voici Pop : le poêle à granulés de 46 cm de diamètre seulement. Laissez-vous conquérir par sa personnalité et ses précieux détails qui le rendent irrésistiblement attrayant. Il est parfait pour une place d'angle, grâce à la sortie des fumées centrale, dans l'axe du poêle. Top en fonte colorée dans la teinte des flancs en acier. Disponible également en version étanche.

ENG Are you a music lover dreaming of a glamorous look? Here's to you Pop: the pellet stove in just 46 cm in diameter. Let it conquer you with its personality and precious details that make it irresistibly attractive. Perfect for any corner placement, thanks to the central smoke outlet in line with the stove. Cast iron top and sides in steel. Also available in hermetic version.

DEU Sind Sie ein Musikliebhaber, der von einem glamourösen Look träumt? Hier ist, Pop: Der Pelletofen mit einem Durchmesser von nur 46 cm. Lassen Sie sich von seiner Persönlichkeit und seinen präzisen Details bezaubern, die ihn unwiderstehlich attraktiv machen. Perfekt für jede Eckaufstellung, dank des zentralen Rauchrohrabgangs, der sich in der Achse auf der Rückseite des Ofens befindet. Eine gusseiserne Topabdeckung rundet die Erscheinung passend zu den Seitenwänden aus Stahl ab. Verfüegbar auch in dem hermetischen Modell.

ESP ¿Eres amante de la música y sueñas con un estilo glamour? Por ti ahora hay Pop: la estufa de pellets con un diámetro de sólo 46 cm, déjate llevar por su personalidad y los preciosos detalles que la hacen irresistiblemente atractiva. Perfecta para el posicionamiento de las esquinas, gracias a la salida central de humos en línea con la estufa. Tapa de hierro fundido y los lados de acero. Disponible también en versión hermética.

**Uscita fumi centrale
in asse con la stufa**
Sortie de fumée centrale
postérieure en axe avec le poêle
Smoke outlet in line
with the stove

Top in ghisa
Dessus en fonte
Cast iron top

**Preziosa porta
focolare in cristallo**
Porte de foyer en cristal
Precious glass firebox door



Schermo comandi programmabile
Panneau des commandes programmable
Programmable control screen

**Scambiatore di calore
con tecnologia Thermocore®**
Echangeur de chaleur breveté
avec technologie Thermocore®
Thermocore® pipe
heat exchanger

**Maniglia removibile.
Essenzialità nel design e
maggiore sicurezza**
Poignée amovible.
Design essentiel
et sécurité accrue
Removable handle.
Essentiality in design
and greater safety

Bruciatore in ghisa
Brûleur en fonte
Cast iron burner

**L'elegante design rialzato
della base facilita la pulizia**
L'élégant design rehaussé
de la base simplifie l'entretien
The refined raised base
facilitates the cleaning operations

OPTIONAL:



iCONTROL
Sistema wi-fi iControl con web-App
Système wi-fi iControl avec web-App
Wi-fi system iControl with web-App
Wi-Fi System iControl mit web-App
Sistema wi-fi iControl con web-App



ROOM CONTROL
Termostato ambiente wireless con supporto a muro
Thermostat d'ambiance wireless avec support mural
Room wireless Thermostat with its wall support
Kabelloser Raumthermostat mit Wandhalterung
Termostato de habitación wireless con su soporte de pared

Matt
Black

Bianco

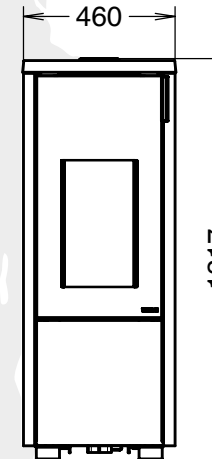
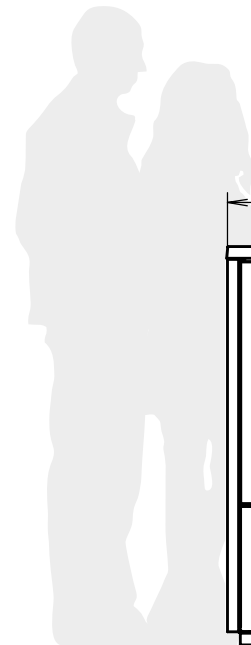

76



1217x460x478



2,5 - 8,9



2,4 - 8,4



0,5 - 1,9



17

Eco DESIGN 2022

5 STELLE
DM 186/7

7 ÉTOILES

POLVERI
9
mg/m³
13% di O₂

CSTB BlmSchV II
le futur en construction



A+ A++



6kW - 10kW natural air

POPSTAR Cristallo

ITA La fiamma ancora più bella, grazie al bruciatore con tecnologia Pellet Power® in grado di riunire funzionalità senza rinunciare al fascino del fuoco. Dotata di una capacità di riserva di pellet di 27 Kg, Popstar è il risultato di un progetto ingegneristico che riunisce il meglio di anni di esperienza e innovazione. Versatile, moderna e senza tempo come una Popstar.

FRA La flamme est encore plus belle, grâce au brûleur doté de la technologie Pellet Power® capable d'allier fonctionnalité sans sacrifier le charme du feu. Avec une capacité de réserve de granulés de 27 Kg, le Popstar est le résultat d'un projet d'ingénierie qui combine le meilleur des années d'expérience et d'innovation. Polyvalent, moderne et intemporel comme une popstar.

ENG The flame even more beautiful, thanks to the burner with Pellet Power® technology able to combine functionality without sacrificing the charm of fire. With a pellet reserve capacity of 27 Kg, Popstar is the result of an engineering project that combines the best of years of experience and innovation. Versatile, modern and timeless like a Popstar.

DEU Die Flamme ist noch schöner, dank des Brenners mit der Pellet Power® Technologie, die in der Lage ist, Funktionalität zu kombinieren, ohne den Charme des Feuers zu verlieren. Mit einer Pelletreservekapazität von 27 Kg ist Popstar das Ergebnis eines Ingenieurprojekts, das das Beste aus jahrelanger Erfahrung und Innovation vereint. Vielseitig, modern und zeitlos wie ein Popstar.

ESP La llama es aún más hermosa, gracias al quemador con tecnología Pellet Power® capaz de combinar la funcionalidad sin sacrificar el encanto del fuego. Con una capacidad de reserva de pellets de 27 Kg, Popstar es el resultado de un proyecto de ingeniería que combina lo mejor de años de experiencia e innovación. Versátil, moderno y atemporal como una Popstar.

Preziosa porta in cristallo
Précieuse porte en cristal
Precious crystal door

Uscita fumi superiore integrata simmetrica per tubo Ø80 mm e coassiale Ø125/130 mm

Sortie des fumées supérieure, intégrée, symétrique pour tuyau Ø80 mm et coaxial Ø125/130 mm
Integrated symmetrical top flue outlet for pipe Ø80 mm and coaxial Ø125/130 mm

Uscita fumi posteriore in asse con la stufa

Sortie des fumées postérieure, dans l'axe du poêle
Rear smoke outlet aligned with the stove

Schermo comandi programmabile a scomparsa

Panneau des commandes rétractable, programmable
Retractable, programmable control panel

Scambiatore di calore con tecnologia Thermocore®

Echangeur de chaleur breveté avec technologie Thermocore®
Heat exchanger with Thermocore® technology

Maniglia removibile. Essenzialità nel design e maggior sicurezza

Poignée amovible. Design essentiel et sécurité accrue
Removable handle. Essentiality in design and greater safety

Bruciatore autopulente brevettato Pelletpower®
Brûleur autonettoyant breveté Pelletpower®
Pelletpower® patented self-cleaning burner

OPTIONAL:



iCONTROL
Sistema wi-fi iControl con web-App
Système wi-fi iControl avec web-App
Wi-Fi system iControl with web-App
Wi-Fi System iControl mit web-App
Sistema wi-fi iControl con web-App



ROOM CONTROL
Termostato ambiente wireless con supporto a muro
Thermostat d'ambiance wireless avec support mural
Room wireless Thermostat with its wall support
Kabelloser Raumthermostat mit Wandhalterung
Termostato de habitación wireless con su soporte de pared



Popstar Stone

Preziosa pietra ollare
Precious soapstone
Précieuse pierre ollaire

Metalcolor

Matt Black

Bianco

Bronze

Cristallo

Nero

Grigio antracite

Stone

Stone

POPSTAR 8 57
POPSTAR 10 87

1284x558x897

POPSTAR 8 2,5- 6,6
POPSTAR 10 ... 2,5 - 10,2

POPSTAR 8 2,4- 6,3
POPSTAR 10 2,4 - 9,6

POPSTAR 8 0,5- 1,4
POPSTAR 10 0,5 - 2,1

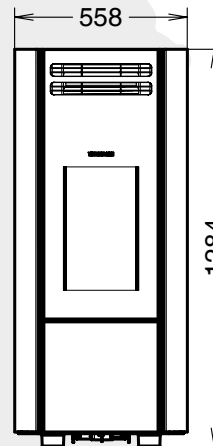

Advanced cleaning
PELLETPOWER®
bruciatore brevettato

Up to
500 hours
NO-STOP

Eco
DESIGN
2022

7
ÉTOILES

CSTB BImSchV II
le futur en construction





	air plus
	12kW natural air
	12kW natural plus



CREO Evo6

- ITA Forme curate, finiture dal forte carattere materico e raffinate tinte monocromatiche fanno di Creo® una stufa a pellet dal design attuale e contemporaneo.
- FRA Des formes soignées, des finitions au caractère fortement matériel, et des teintes monochromes raffinées, font du Creo® un thermo-poêle à granulés au design actuel et contemporain.
- ENG Meticulous finishes with strong materials and refined monochromatic paints make Creo® a pellet thermostove with a modern design.
- DEU Sorgfältige Formen, Ausführungen mit starkem Materialcharakter und raffinierte monochrome Farben machen den Creo® zu einem Pelletofen mit modernem und zeitgemäßem Design.
- ESP Las formas cuidadas, los acabados con un fuerte carácter material y los refinados colores monocromáticos hacen de la Creo® una estufa de pellets con un diseño moderno y contemporáneo.

**Uscite per canalizzazione disponibili:
due posteriori (c)**

Sorties de canalisation disponibles : 2 arrières (c)
Available ducting outlets: two rear (c)

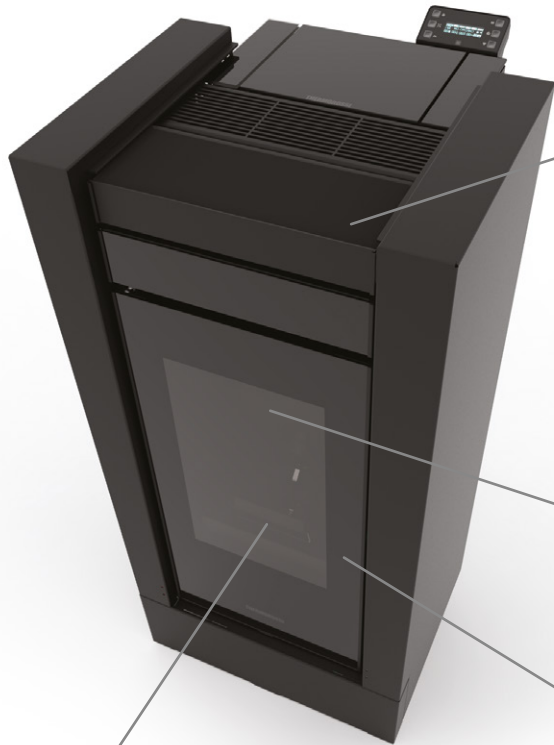

**Top in cristallo con funzione
Natural a qualsiasi potenza (b)**
Top en cristal avec fonction
Natural à tous les niveaux
de puissance (b)
Crystal glass top with Natural
function at any power (b)

**Scambiatore a fascio
tubiero THERMOCORE®**
Échangeur à faisceau
tubulaire THERMOCORE®
THERMOCORE®
pipe heat exchanger

**Porta focolare in vetro
ceramico serigrafato e ghisa**
Porte de foyer en fonte et
cristal imprimé en sérigraphie
Screen-printed ceramic glass
and cast iron firebox door

**Bruciatore autopulente
brevettato Pelletpower® (b)**
Brûleur autonettoyant
breveté Pelletpower® (b)
Pelletpower® patented
self-cleaning burner (b)

OPTIONAL:



iCONTROL
Sistema wi-fi iControl con web-App
Système wi-fi iControl avec web-App
Wi-fi system iControl with web-App
Wi-Fi System iControl mit web-App
Sistema wi-fi iControl con web-App



ROOM CONTROL
Termostato ambiente wireless con supporto a muro
Thermostat d'ambiance wireless avec support mural
Room wireless Thermostat with its wall support
Kabelloser Raumthermostat mit Wandhalterung
Termostato de habitación wireless con su soporte de pared

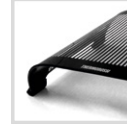

DINNER (a)
Coperchio scalda vivande in cristallo
Couvercle chauffe-plat en cristal
Glass food-warming cover
Warmhalteplatte aus Kristallglas
Chapa para calentar comidas

(a) Solo per versione "Air - Plus" - Uniquement version "Air - Plus"
Only on "Air - Plus" version

Matt
Black

Air/Plus 102
N.Air/N.Plus 12 102

Air 1106x543x583
Plus 1104x543x588
N. Air 12 1103x543x577
N.Plus 12 1103x543x576

Air/Plus 3,8 - 12,3
N.Air/N.Plus 12 3,2 - 12,2

Air/Plus 3,5 - 11,3
N.Air/N.Plus 12 3,1 - 11,3

Air/Plus 0,8 - 2,55
N.Air/N.Plus 12 0,65 - 2,6

Air 19
Plus 15
N. Air 12 20,7
N.Plus 12 17,2



(b) **Advanced cleaning
PELLETPOWER®**
bruciatore brevettato

**Up to
500 hours
NO-STOP**

**Eco
DESIGN
2022**

**5
STELLE
DM 186/7**

**7
ÉTOILES**

**POLVERI (a)
7
mg/m³
13% di O₂**

**POLVERI (b)
9
mg/m³
13% di O₂**

CSTB BlmSchV II
le futur en construction



(b)

(c) 16mx1
8mx2

(b)

(b)

(b)

(b) Solo per versione "Natural Air - Natural Plus" - Uniquement version "Natural Air - Natural Plus" - Only on "Natural Air - Natural Plus" version
(c) Solo per versione "Plus - Natural Plus" - Uniquement version "Plus - Natural Plus" - Only on "Plus - Natural Plus" version

La tipologia di fiamma ed il focolare possono variare a seconda delle versioni
Le type de flamme et le foyer peuvent varier selon les versions
Flame and the firebox can vary according to different model

A+ A++
↑
G



14kW - 18kW - 21kW idra



CREO idra

ITA Forme curate, finiture dal forte carattere materico e raffinate tinte monocromatiche fanno di Creo® una stufa a pellet dal design attuale e contemporaneo.

FRA Des formes soignées, des finitions au caractère fortement matériel, et des teintes monochromes raffinées, font du Creo® un thermo-poêle à granulés au design actuel et contemporain.

ENG Meticulous finishes with strong materials and refined monochromatic paints make Creo® a pellet thermostove with a modern design.

DEU Sorgfältige Formen, Ausführungen mit starkem Materialcharakter und raffinierte monochrome Farben machen den Creo® zu einem Pelletofen mit modernem und zeitgemäßem Design.

ESP Las formas cuidadas, los acabados con un fuerte carácter material y los refinados colores monocromáticos hacen de la Creo® una estufa de pellets con un diseño moderno y contemporáneo.

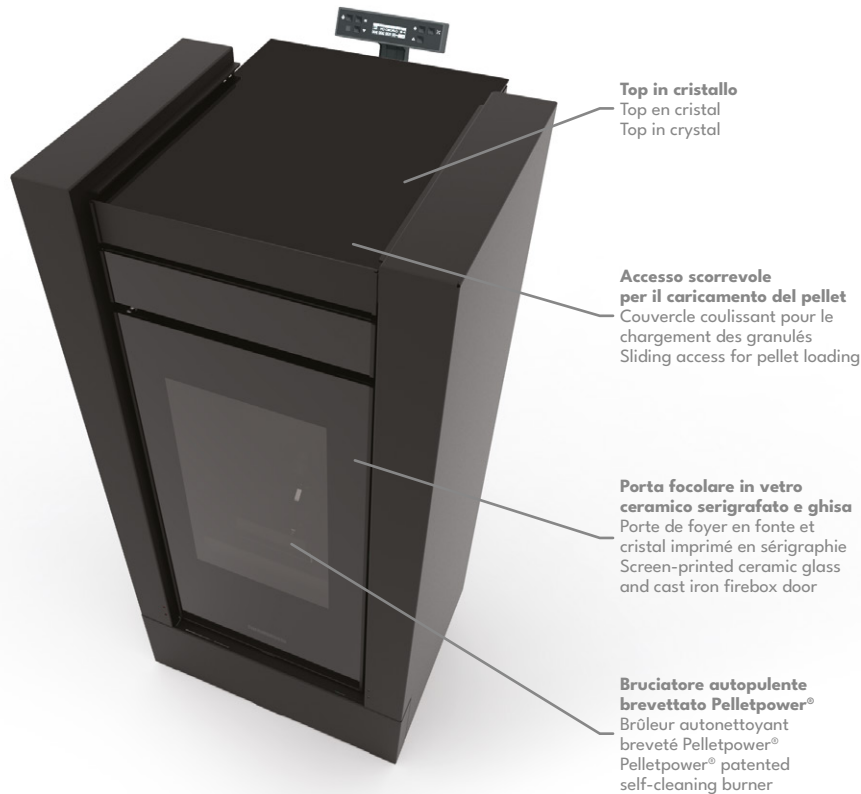

OPTIONAL:



INTEGRA TR-PACK
Thermocell® (250/400/500 lt)
Thermopuffer (400/500/1500 lt)
Thermosole® (2.0)



Thermofan:
Kit di ventilazione termostufa
Kit de ventilation thermo-poêle
Pellet thermo-stoves air convection kit
Raumluftventilator für Pelletsofenwassergeführt
Pellet thermo-stoves kit de convection de aire



Valvola termostatica a 3 vie 1" FFF 55 OT (optional)
Vanne thermostatique 3 voies 1" FFF 55 OT (optional)
Thermostatic valve 3 ways 1" FFF 55 OT (optional)

Sonda PT100 (optional-min 2 pz) per funzione «THERMOCONTROL»
Sonde PT100 (optional-min 2 pces) pour fonction «THERMOCONTROL»
PT100 sensor (optional-min 2 pc) for «THERMOCONTROL» function



iCONTROL
Sistema wi-fi iControl con web-App
Système wi-fi iControl avec web-App
Wi-fi system iControl with web-App
Wi-Fi System iControl mit web-App
Sistema wi-fi iControl con web-App



ROOM CONTROL
Termostato ambiente wireless con supporto a muro
Thermostat d'ambiance wireless avec support mural
Room wireless Thermostat with its wall support
Kabelloser Raumthermostat mit Wandhalterung
Termostato de habitación wireless con su soporte de pared

Idra 14	118
Idra 18 Evo	160
Idra 21	191

1108x543x572

Idra 14	5,3 - 13,7
Idra 18 Evo	5,4 - 18,9
Idra 21	5,3 - 22,5

Idra 14	5,1 - 13,1
Idra 18 Evo	5,3 - 17,8
Idra 21	5,1 - 21,2

Idra 14	3,8 - 10,9
Idra 18 Evo	3,7 - 15,0
Idra 21	3,8 - 17,9

Idra 14	1,1 - 2,8
Idra 18 Evo	1,1 - 3,9
Idra 21	1,1 - 4,6

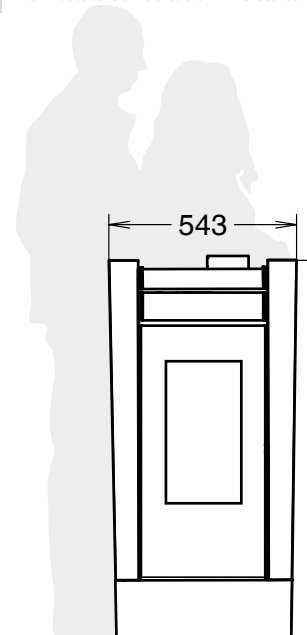

Advanced cleaning
PELLETPOWER®
bruciatore brevettato

Up to
500 hours
NO-STOP

Eco
DESIGN
2022

5
STELLE
DM 186/7

7
ÉTOILES

BimSchV II



Matt
Black



12kW natural air

12kW natural plus



CREO supreme Evo6

ITA Forme curate, finiture dal forte carattere materico e raffinate tinte monocromatiche fanno di Creo® una stufa a pellet dal design attuale e contemporaneo.

FRA Des formes soignées, des finitions au caractère fortement matériel, et des teintes monochromes raffinées, font du Creo® un thermo-poêle à granulés au design actuel et contemporain.

ENG Meticulous finishes with strong materials and refined monochromatic paints make Creo® a pellet thermostat with a modern design.

DEU Sorgfältige Formen, Ausführungen mit starkem Materialcharakter und raffinierte monochrome Farben machen den Creo® zu einem Pelletofen mit modernem und zeitgemäßem Design.

ESP Las formas cuidadas, los acabados con un fuerte carácter material y los refinados colores monocromáticos hacen de la Creo® una estufa de pellets con un diseño moderno y contemporáneo.

**Uscite per canalizzazione disponibili:
due posteriori (a)**

Sorties de canalisation disponibles : 2 arrières (a)
Available ducting outlets: two rear (a)

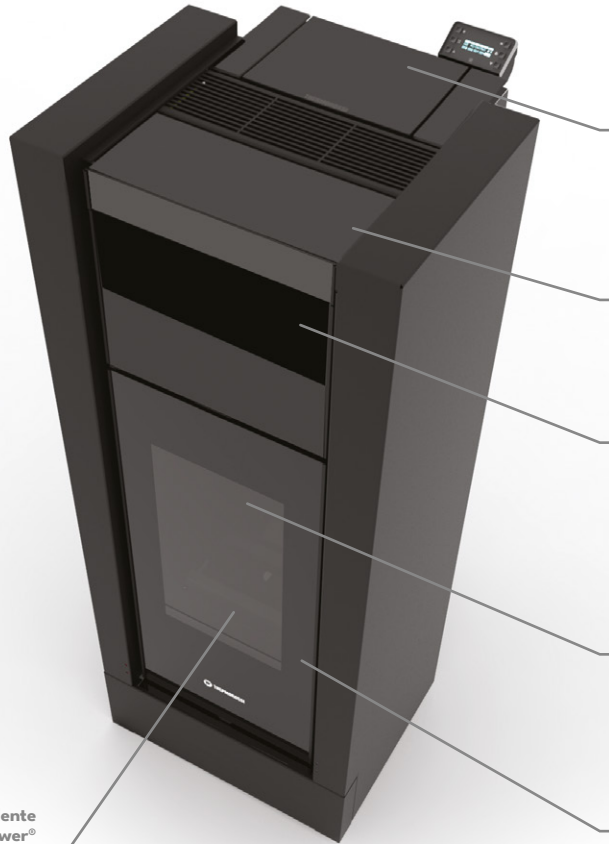

**Accesso per il
caricamento del pellet**
Couvercle pour le
chargement des granulés
Access for pellet loading

**Top in cristallo con funzione
Natural a qualsiasi potenza**
Top en cristal avec fonction
Natural à tous les niveaux
de puissance
Crystal glass top with Natural
function at any power

Vano scaldavivande
Compartment chauffe-plats
Food warming compartment

**Scambiatore a fascio
tubiero THERMOCORE®**
Échangeur à faisceau
tubulaire THERMOCORE®
THERMOCORE®
pipe heat exchanger

**Porta focolare in vetro
ceramico serigrafato e ghisa**
Porte de foyer en fonte et
cristal imprimé en sérigraphie
Screen-printed ceramic glass
and cast iron firebox door

**Bruciatore autopulente
brevettato Pelletpower®**
Brûleur autonettoyant
breveté Pelletpower®
Pelletpower® patented
self-cleaning burner

OPTIONAL:



iCONTROL
Sistema wi-fi iControl con web-App
Système wi-fi iControl avec web-App
Wi-fi system iControl with web-App
Wi-Fi System iControl mit web-App
Sistema wi-fi iControl con web-App



ROOM CONTROL
Termostato ambiente wireless con supporto a muro
Thermostat d'ambiance wireless avec support mural
Room wireless Thermostat with its wall support
Kabelloser Raumthermostat mit Wandhalterung
Termostato de habitación wireless con su soporte de pared

Matt
Black



102



1301x550x591



3,2 - 12,2



3,1 - 11,3



0,65 - 2,6



N.Air 29,5
N.Plus 26



Advanced cleaning
PELLETPOWER®
bruciatore brevettato

Up to
500 hours
NO-STOP

Eco
DESIGN
2022

5
STELLE
DM 186/7

7
ÉTOILES

POLVERI
9
mg/m³
13% di O₂

CSTB BImSchV II
le futur en construction



(a) 16mx1
8mx2

(a) Solo per versione "Natural Plus" - Uniquement version "Natural Plus" - Only on "Natural Plus" version

La tipologia di fiamma ed il focolare possono variare a seconda delle versioni
Le type de flamme et le foyer peuvent varier selon les versions
Flame and the firebox can vary according to different model



supreme - 29kW idra



CREO

supreme idra
idra 29 Evo

ITA Forme curate, finiture dal forte carattere materico e raffinate tinte monocromatiche fanno di Creo® una stufa a pellet dal design attuale e contemporaneo.

FRA Des formes soignées, des finitions au caractère fortement matériel, et des teintes monochromes raffinées, font du Creo® un thermo-poêle à granulés au design actuel et contemporain.

ENG Meticulous finishes with strong materials and refined monochromatic paints make Creo® a pellet thermostove with a modern design.

DEU Sorgfältige Formen, Ausführungen mit starkem Materialcharakter und raffinierte monochrome Farben machen den Creo® zu einem Pelletofen mit modernem und zeitgemäßem Design.

ESP Las formas cuidadas, los acabados con un fuerte carácter material y los refinados colores monocromáticos hacen de la Creo® una estufa de pellets con un diseño moderno y contemporáneo.



Piano igienico, in cristallo
Plateau hygiénique en cristal
Hygienic glass top

Accesso scorrevole per il caricamento del pellet
Couvercle coulissant pour le chargement des granulés
Sliding access for pellet loading

Porta focolare in vetro ceramico serigrafato e ghisa
Porte de foyer en fonte et cristal imprimé en sérigraphie
Screen-printed ceramic glass and cast iron firebox door

Bruciatore autopulente brevettato Pelletpower®
Brûleur autonettoyant breveté Pelletpower®
Pelletpower® patented self-cleaning burner

OPTIONAL:



INTEGRA TR-PACK

Thermocell® (250/400/500 lt)
Thermopuffer (400/500/1500 lt)
Thermosole® (2.0)



Thermofan:

Kit di ventilazione termostufa

Kit de ventilation thermo-poêle
Pellet thermo-stoves air convection kit
Raumlüftventilator für Pelletsofenwassergeführt
Pellet thermo-stoves kit de convección de aire



Valvola termostatica a 3 vie 1" FFF 55 OT (optional);
Vanne thermostatique 3 voies 1" FFF 55 OT (optional);
Thermostatic valve 3 ways 1" FFF 55 OT (optional);

Sonda PT100 (optional-min 2 pz) per funzione «THERMOCONTROL»;
Sonde PT100 (optional-min 2 pces) pour fonction «THERMOCONTROL»;
PT100 sensor (optional-min 2 pc) for «THERMOCONTROL» function;



iCONTROL

Sistema wi-fi iControl con web-App.

Système wi-fi iControl avec web-App.
Wi-fi system iControl with web-App.
Wi-Fi System iControl mit web-App.
Sistema wi-fi iControl con web-App.



ROOM CONTROL

Termostato ambiente wireless con supporto a muro.

Thermostat d'ambiance wireless avec support mural.
Room wireless Thermostat with its wall support.
Kabelloser Raumthermostat mit Wandhalterung.
Termostato de habitación wireless con su soporte de pared.

Idra Supreme..... 203
Idra29Evo 213

1301x550x591

Idra Supreme..... 6,8 - 23,7
Idra29Evo 9,1 - 25,4

Idra Supreme..... 6,5 - 22,5
Idra29Evo 8,6 - 23,7

Idra Supreme..... 5,0 - 19,6
Idra29Evo 7,3 - 20,6

Idra Supreme..... 1,4 - 4,9
Idra29Evo 1,9 - 5,25

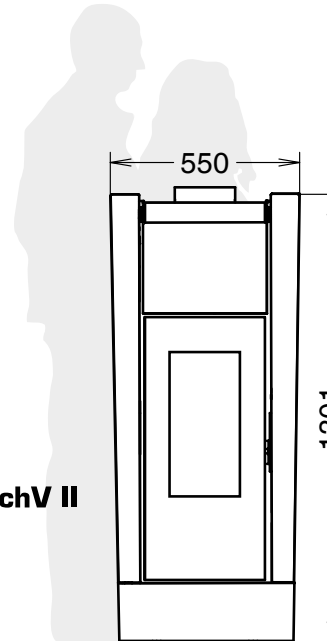

BlmSchV II

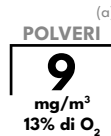

(a) Solo per versione "Idra29Evo" - Uniquement version "Idra29Evo" - Only on "Idra29Evo" version

Matt Black

A⁺ A⁺⁺
↑
G



air



plus



12kW natural air



12kW natural plus



MOMA Evo6

ITA Caratterizzata da uno stile minimalista e sobrio, i suoi dettagli funzionali ed essenziali realizzati con materiali resistenti quali l'acciaio e la ghisa, donano fascino e robustezza.

FRA Caractérisé par un style minimaliste et sobre, ses détails fonctionnels et essentiels, réalisés avec des matériaux résistants tels que l'acier et la fonte, lui confèrent charme et robustesse.

ENG Characterized by a minimalist and sober style, its functional and essential details made with resistant materials such as steel and cast iron, give charm and robustness.

DEU Sie zeichnet sich durch einen minimalistischen und nüchternen Stil aus und verleiht mit ihren funktionalen und wesentlichen Details aus widerstandsfähigen Materialien wie Stahl und Gusseisen Charme und Robustheit.

ESP Caracterizado por un estilo minimalista y sobrio, sus detalles funcionales y esenciales hechos con materiales resistentes como el acero y el hierro fundido, dan encanto y robustez.

Uscite per canalizzazione disponibili:
due posteriori (c)

Sorties de canalisation disponibles : 2 arrières (c)
Available ducting outlets: two rear (c)



Schermo comandi programmabile
Panneau des commandes programmable
Programmable control screen

Top in ghisa
Top en fonte
Cast iron top

Top in cristallo con funzione Natural a qualsiasi potenza (b)
Top en cristal avec fonction Natural à tous les niveaux de puissance (b)
Crystal glass top with Natural function at any power (b)

Porta focolare in vetro ceramico serigrafato e ghisa
Porte de foyer en fonte et cristal imprimé en sérigraphie
Screen-printed ceramic glass and cast iron firebox door

Brucciante autopulente brevettato Pelletpower® (b)
Brûleur autonettoyant breveté Pelletpower® (b)
Pelletpower® patented self-cleaning burner (b)

Piano salva cenere
Base ramasse-cendre
Ash saving floor

OPTIONAL:



iCONTROL
Sistema wi-fi iControl con web-App
Système wi-fi iControl avec web-App
Wi-fi system iControl with web-App
Wi-Fi System iControl mit web-App
Sistema wi-fi iControl con web-App



ROOM CONTROL
Termostato ambiente wireless con supporto a muro
Thermostat d'ambiance wireless avec support mural
Room wireless Thermostat with its wall support
Kabelloser Raumthermostat mit Wandhalterung
Termostato de habitación wireless con su soporte de pared

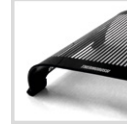

DINNER (a)
Coperchio scaldia vivande in cristallo
Couverture chauffe-plat en cristal
Glass food-warming cover
Warmhalteplatte aus Kristallglas
Chapa para calentar comidas

(a) Solo per versione "Air - Plus" - Uniquement version "Air - Plus"
Only on "Air - Plus" version

Matt Black



Bronze



Air/Plus 102
N.Air/N.Plus 12 102



Air 1160x534x632
Plus 1159x534x632
N.Air 12 1159x534x628
N.Plus 12 1159x534x628



Air/Plus 3,8 - 12,3
N.Air/N.Plus 12 3,2 - 12,2



Air/Plus 3,5 - 11,3
N.Air/N.Plus 12 3,1 - 11,3



Air/Plus 0,8 - 2,55
N.Air/N.Plus 12 0,65 - 2,6



Air 19
Plus 15
N.Air 12 20,7
N.Plus 12 17,2



(b) **Advanced cleaning**
PELLETPOWER®
bruciatore brevettato

Up to 500 hours NO-STOP

Eco DESIGN 2022

5 STELLE
DM 186/7

7 ÉTOILES

POLVERI (a)
7 mg/m³
13% di O₂

POLVERI (b)
9 mg/m³
13% di O₂

CSTB BlmSchV II
le futur en construction



(b)

(c) 16mx1 8mx2

(b)

(b)

(b)

(b) Solo per versione "Natural Air - Natural Plus" - Uniquement version "Natural Air - Natural Plus" - Only on "Natural Air - Natural Plus" version
(c) Solo per versione "Plus - Natural Plus" - Uniquement version "Plus - Natural Plus" - Only on "Plus - Natural Plus" version

La tipologia di fiamma ed il focolare possono variare a seconda delle versioni
Le type de flamme et le foyer peuvent varier selon les versions
Flame and the firebox can vary according to different model



A⁺ A⁺⁺



14kW - 18kW - 21kW idra

MOMA idra

ITA Caratterizzata da uno stile minimalista e sobrio, i suoi dettagli funzionali ed essenziali realizzati con materiali resistenti quali l'acciaio e la ghisa, donano fascino e robustezza.

FRA Caractérisé par un style minimaliste et sobre, ses détails fonctionnels et essentiels, réalisés avec des matériaux résistants tels que l'acier et la fonte, lui confèrent charme et robustesse.

ENG Characterized by a minimalist and sober style, its functional and essential details made with resistant materials such as steel and cast iron, give charm and robustness.

DEU Sie zeichnet sich durch einen minimalistischen und nüchternen Stil aus und verleiht mit ihren funktionalen und wesentlichen Details aus widerstandsfähigen Materialien wie Stahl und Gusseisen Charme und Robustheit.

ESP Caracterizado por un estilo minimalista y sobrio, sus detalles funcionales y esenciales hechos con materiales resistentes como el acero y el hierro fundido, dan encanto y robustez.

Schermo comandi programmabile
Panneau des commandes programmable
Programmable control screen



OPTIONAL:



INTEGRA TR-PACK
Thermocell® (250/400/500 lt)
Thermopuffer (400/500/1500 lt)
Thermosole® (2.0)

Matt
Black



Thermofan:
Kit di ventilazione termostufa
Kit de ventilation thermo-poêle
Pellet thermo-stoves air convection kit
Raumluftventilator für Pelletsöfenwassergeführt
Pellet thermo-stoves kit de convection de aire

Bronze



Valvola termostatica a 3
vie 1" FFF 55 OT (optional)
Vanne thermostatique 3
voies 1" FFF 55 OT (optional)
Thermostatic valve 3 ways
1" FFF 55 OT (optional)

Sonda PT100 (optional-min 2 pz)
per funzione «THERMOCONTROL»
Sonde PT100 (optional-min 2 pces)
pour fonction «THERMOCONTROL»
PT100 sensor (optional-min 2 pc)
for «THERMOCONTROL» function



iCONTROL
Sistema wi-fi iControl con web-App
Système wi-fi iControl avec web-App
Wi-fi system iControl with web-App
Wi-Fi System iControl mit web-App
Sistema wi-fi iControl con web-App



ROOM CONTROL
Termostato ambiente wireless con supporto a muro
Thermostat d'ambiance wireless avec support mural
Room wireless Thermostat with its wall support
Kabelloser Raumthermostat mit Wandhalterung
Termostato de habitación wireless con su soporte de pared

Idra 14	118
Idra 18 Evo	160
Idra 21	191

1166x534x632

Idra 14	5,3 - 13,7
Idra 18 Evo	5,4 - 18,9
Idra 21	5,3 - 22,5

Idra 14	5,1 - 13,1
Idra 18 Evo	5,3 - 17,8
Idra 21	5,1 - 21,2

Idra 14	3,8 - 10,9
Idra 18 Evo	3,7 - 15,0
Idra 21	3,8 - 17,9

Idra 14	1,1 - 2,8
Idra 18 Evo	1,1 - 3,9
Idra 21	1,1 - 4,6

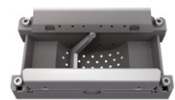
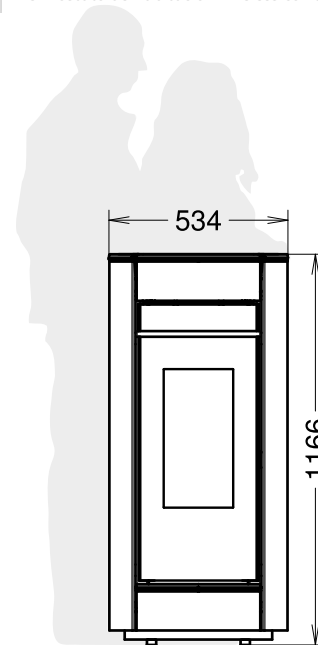

Advanced cleaning
PELLETPOWER®
bruciatore brevettato

Up to
500 hours
NO-STOP

Eco
DESIGN
2022

5
STELLE
DM 186/7

7
ÉTOILES

BimSchV II



La tipologia di fiamma ed il focolare possono variare a seconda delle versioni
Le type de flamme et le foyer peuvent varier selon les versions
Flame and the firebox can vary according to different model



12kW natural air

12kW natural plus

MOMA supreme Evo6

- ITA Caratterizzata da uno stile minimalista e sobrio, i suoi dettagli funzionali ed essenziali realizzati con materiali resistenti quali l'acciaio e la ghisa, donano fascino e robustezza.
- FRA Caractérisé par un style minimaliste et sobre, ses détails fonctionnels et essentiels, réalisés avec des matériaux résistants tels que l'acier et la fonte, lui confèrent charme et robustesse.
- ENG Characterized by a minimalist and sober style, its functional and essential details made with resistant materials such as steel and cast iron, give charm and robustness.
- DEU Sie zeichnet sich durch einen minimalistischen und nüchternen Stil aus und verleiht mit ihren funktionalen und wesentlichen Details aus widerstandsfähigen Materialien wie Stahl und Gusseisen Charme und Robustheit.
- ESP Caracterizado por un estilo minimalista y sobrio, sus detalles funcionales y esenciales hechos con materiales resistentes como el acero y el hierro fundido, dan encanto y robustez.

**Uscite per canalizzazione disponibili:
due posteriori (a)**
Sorties de canalisation disponibles :
2 arrières (a)
Available ducting outlets: two rear (a)

**Accesso per il
caricamento del pellet**
Couvercle pour le
chargement des granulés
Access for pellet loading

Schermo comandi programmabile
Panneau des commandes
programmable
Programmable control screen

Top in ghisa
Top en fonte
Cast iron top

**Vano scaldavivande
con piano in ghisa**
Compartment chauffe-plats
avec plateau en fonte
Food warming compartment
with cast iron top

**Porta focolare in vetro
ceramico serigrafato e ghisa**
Porte de foyer en fonte et
cristal imprimé en sérigraphie
Screen-printed ceramic glass
and cast iron firebox door

OPTIONAL:



iCONTROL
Sistema wi-fi iControl con web-App
Système wi-fi iControl avec web-App
Wi-fi system iControl with web-App
Wi-Fi System iControl mit web-App
Sistema wi-fi iControl con web-App



ROOM CONTROL
Termostato ambiente wireless con supporto a muro
Thermostat d'ambiance wireless avec support mural
Room wireless Thermostat with its wall support
Kabelloser Raumthermostat mit Wandhalterung
Termostato de habitación wireless con su soporte de pared

Matt
Black

Bronze



102



1372x537x628



3,1 - 12,2



3,1 - 11,3



0,65 - 2,6



N.Air 29,5
N.Plus 26



Advanced cleaning
PELLETPOWER®
bruciatore brevettato

Up to
500 hours
NO-STOP

Eco
DESIGN
2022

5
STELLE
DM 186/7

7
ÉTOILES

POLVERI
9
mg/m³
13% di O₂

CSTB **BImSchV II**
le futur en construction



(a) 16mx1
8mx2

(a) Solo per versione "Natural Plus" - Uniquement version "Natural Plus" - Only on "Natural Plus" version

La tipologia di fiamma ed il focolare possono variare a seconda delle versioni
Le type de flamme et le foyer peuvent varier selon les versions
Flame and the firebox can vary according to different model



supreme - 29kW idra



MOMA

supreme idra
idra 29 Evo

- ITA Caratterizzata da uno stile minimalista e sobrio, i suoi dettagli funzionali ed essenziali realizzati con materiali resistenti quali l'acciaio e la ghisa, donano fascino e robustezza.
- FRA Caractérisé par un style minimaliste et sobre, ses détails fonctionnels et essentiels, réalisés avec des matériaux résistants tels que l'acier et la fonte, lui confèrent charme et robustesse.
- ENG Characterized by a minimalist and sober style, its functional and essential details made with resistant materials such as steel and cast iron, give charm and robustness.
- DEU Sie zeichnet sich durch einen minimalistischen und nüchternen Stil aus und verleiht mit ihren funktionalen und wesentlichen Details aus widerstandsfähigen Materialien wie Stahl und Gusseisen Charme und Robustheit.
- ESP Caracterizado por un estilo minimalista y sobrio, sus detalles funcionales y esenciales hechos con materiales resistentes como el acero y el hierro fundido, dan encanto y robustez.

Schermo comandi programmabile
Panneau des commandes programmable
Programmable control screen



Top in ghisa
Top en fonte
Cast iron top

Piano igienico, in cristallo
Plateau hygiénique en cristal
Hygienic glass top

Accesso scorrevole per il caricamento del pellet
Couvercle coulissant pour le chargement des granulés
Sliding access for pellet loading

Porta focolare in vetro ceramico serigrafato e ghisa
Porte de foyer en fonte et cristal imprimé en sérigraphie
Screen-printed ceramic glass and cast iron firebox door

Brucciante autopulente brevettato Pelletpower®
Brûleur autonettoyant breveté Pelletpower®
Pelletpower® patented self-cleaning burner

Piano salva cenere in ghisa
Base ramasse-cendres en fonte
Cast iron ash saving floor

OPTIONAL:



INTEGRA TR-PACK
Thermocell® (250/400/500 lt)
Thermopuffer (400/500/1500 lt)
Thermosole® (2.0)

Matt
Black



Thermofan:
Kit di ventilazione termostufa
Kit de ventilation thermo-poêle
Pellet thermo-stoves air convection kit
Raumlüftventilator für Pelletsofenwassergeführt
Pellet thermo-stoves kit de convection de aire

Bronze



Valvola termostatica a 3 vie 1" FFF 55 OT (optional)
Vanne thermostatique 3 voies 1" FFF 55 OT (optional)
Thermostatic valve 3 ways 1" FFF 55 OT (optional)

Sonda PT100 (optional-min 2 pz) per funzione «THERMOCONTROL»
Sonde PT100 (optional-min 2 pces) pour fonction «THERMOCONTROL»
PT100 sensor (optional-min 2 pc) for «THERMOCONTROL» function



iCONTROL
Sistema wi-fi iControl con web-App
Système wi-fi iControl avec web-App
Wi-fi system iControl with web-App
Wi-Fi System iControl mit web-App
Sistema wi-fi iControl con web-App



ROOM CONTROL
Termostato ambiente wireless con supporto a muro
Thermostat d'ambiance wireless avec support mural
Room wireless Thermostat with its wall support
Kabelloser Raumthermostat mit Wandhalterung
Termostato de habitación wireless con su soporte de pared

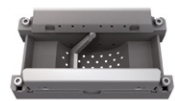

Advanced cleaning
PELLETPOWER®
bruciatore brevettato

Up to
500 hours
NO-STOP

Eco
DESIGN
2022

(a) **5**
STELLE
DM 186/7

7
ÉTOILES

(a) **POLVERI**
9
mg/m³
13% di O₂

BlmSchV II

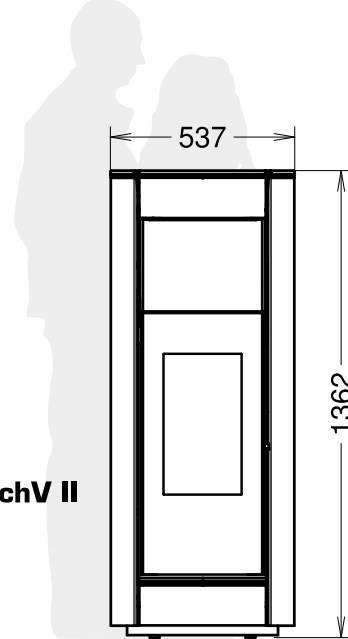

Idra Supreme..... 203
Idra29Evo 213

1362x537x638

Idra Supreme..... 6,8 - 23,7
Idra29Evo 9,1 - 25,4

Idra Supreme..... 6,5 - 22,5
Idra29Evo 8,6 - 23,7





Idra Supreme..... 5,0 - 19,6
Idra29Evo 7,3 - 20,6

Idra Supreme..... 1,4 - 4,9
Idra29Evo 1,9 - 5,25



(a) Solo per versione "Idra29Evo" - Uniquement version "Idra29Evo" - Only on "Idra29Evo" version

A+ A++
↑
G

	air
	plus
	12kW natural air
	12kW natural plus



CHIC Evo6

- ITA Chic, la stufa a pellet dallo stile raffinato e senza tempo, per rendere la tua casa un luogo romantico ed elegante.
- FRA Chic, le poêle à granulés au style raffiné et intemporel, pour faire de votre maison un lieu romantique et élégant.
- ENG Chic, the pellet stove with a refined and timeless style, to make your home a romantic and elegant place.
- DEU Chic, der Pelletofen mit einem raffinierten und zeitlosen Stil, um Ihr Zuhause zu einem romantischen und eleganten Ort zu machen.
- ESP Chic, la estufa de pellets con un estilo refinado e intemporal, para hacer de su casa un lugar romántico y elegante.

Uscite per canalizzazione disponibili:
due posteriori (c)

Sorties de canalisation disponibles : 2 arrières (c)
Available ducting outlets: two rear (c)



Schermo comandi programmabile
Panneau des commandes programmable
Programmable control screen

Top in cristallo con funzione Natural a qualsiasi potenza (b)
Top en cristal avec fonction Natural à tous les niveaux de puissance (b)
Crystal glass top with Natural function at any power (b)

Preziosa maiolica artigianale fatta a mano
Précieuses céramiques artisanales faites à la main
Precious handmade majolica tiles

Porta focolare in vetro ceramico serigrafato e ghisa
Porte de foyer en fonte et cristal imprimé en sérigraphie
Screen-printed ceramic glass and cast iron firebox door

Brucciore autopulente brevettato Pelletpower® (b)
Brûleur autonettoyant breveté Pelletpower® (b)
Pelletpower® patented self-cleaning burner (b)

OPTIONAL:



iCONTROL
Sistema wi-fi iControl con web-App
Système wi-fi iControl avec web-App
Wi-fi system iControl with web-App
Wi-Fi System iControl mit web-App
Sistema wi-fi iControl con web-App



ROOM CONTROL
Termostato ambiente wireless con supporto a muro
Thermostat d'ambiance wireless avec support mural
Room wireless Thermostat with its wall support
Kabelloser Raumthermostat mit Wandhalterung
Termostato de habitación wireless con su soporte de pared

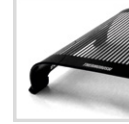

DINNER (a)
Coperchio scalda vivande in cristallo
Couvercle chauffe-plat en cristal
Glass food-warming cover
Warmhalteplatte aus Kristallglas
Chapa para calentar comidas

(a) Solo per versione "Air - Plus" - Uniquement version "Air - Plus"
Only on "Air - Plus" version

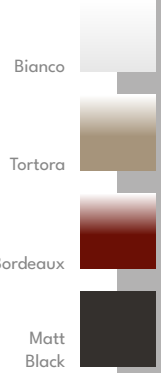

	Air/Plus	102	
	N. Air/N.Plus 12	102	
	Air	1130x565x648	mm
	Plus	1130x565x648	
	N. Air 12	1130x565x644	
	N.Plus 12	1130x565x644	
	Air/Plus	3,8 - 12,3	kW
	N. Air/N.Plus 12	3,2 - 12,2	
	Air/Plus	3,5 - 11,3	kW NOM.
	N. Air/N.Plus 12	3,1 - 11,3	
	Air/Plus	0,8 - 2,55	kW
	N. Air/N.Plus 12	0,65 - 2,6	
	Air	19	
	Plus	15	
	N. Air 12	20,7	kW
	N.Plus 12	17,2	



(b) **Advanced cleaning PELLETPOWER®**
bruciatore brevettato

Up to 500 hours NO-STOP

Eco DESIGN 2022

5 STELLE DM 186/7

7 ÉTOILES

POLVERI (a)
7 mg/m³
13% di O₂

POLVERI (b)
9 mg/m³
13% di O₂

CSTB BlmSchV II
le futur en construction



(b)

(c) 16mx1 8mx2

(b)

(b)

(b)

(b) Solo per versione "Natural Air - Natural Plus" - Uniquement version "Natural Air - Natural Plus" - Only on "Natural Air - Natural Plus" version
(c) Solo per versione "Plus - Natural Plus" - Uniquement version "Plus - Natural Plus" - Only on "Plus - Natural Plus" version

La tipologia di fiamma ed il focolare possono variare a seconda delle versioni
Le type de flamme et le foyer peuvent varier selon les versions
Flame and the firebox can vary according to different model

A⁺ A⁺⁺
↑
G



14kW - 18kW - 21kW idra



CHIC idra

ITA Chic, la stufa a pellet dallo stile raffinato e senza tempo, per rendere la tua casa un luogo romantico ed elegante.

FRA Chic, le poêle à granulés au style raffiné et intemporel, pour faire de votre maison un lieu romantique et élégant.

ENG Chic, the pellet stove with a refined and timeless style, to make your home a romantic and elegant place.

DEU Chic, der Pelletofen mit einem raffinierten und zeitlosen Stil, um Ihr Zuhause zu einem romantischen und eleganten Ort zu machen.

ESP Chic, la estufa de pellets con un estilo refinado e intemporal, para hacer de su casa un lugar romántico y elegante.



Schermo comandi programmabile
 Panneau des commandes programmable
 Programmable control screen

Accesso scorrevole per il caricamento del pellet
 Couvercle coulissant pour le chargement des granulés
 Sliding access for pellet loading

Preziosa maiolica artigianale fatta a mano
 Précieuses céramiques artisanales faites à la main
 Precious handmade majolica tiles

Porta focolare in vetro ceramico serigrafato e ghisa
 Porte de foyer en fonte et cristal imprimé en sérigraphie
 Screen-printed ceramic glass and cast iron firebox door

Briatore autopulente brevettato Pelletpower®
 Brûleur autonettoyant breveté Pelletpower®
 Pelletpower® patented self-cleaning burner

OPTIONAL:



INTEGRA TR-PACK
 Thermocell® (250/400/500 lt)
 Thermopuffer (400/500/1500 lt)
 Thermosole® (2.0)



Thermofan:
Kit di ventilazione termostufa
 Kit de ventilation thermo-poêle
 Pellet thermo-stoves air convection kit
 Raumluftventilator für Pelletsofenwassergeführt
 Pellet thermo-stoves kit de convección de aire



Valvola termostatica a 3 vie 1" FFF 55 OT (optional)
 Vanne thermostatique 3 voies 1" FFF 55 OT (optional)
 Thermostatic valve 3 ways 1" FFF 55 OT (optional)



Sonda PT100 (optional-min 2 pz) per funzione «THERMOCONTROL»
 Sonde PT100 (optional-min 2 pces) pour fonction «THERMOCONTROL»
 PT100 sensor (optional-min 2 pc) for «THERMOCONTROL» function



iCONTROL
Sistema wi-fi iControl con web-App
 Système wi-fi iControl avec web-App
 Wi-fi system iControl with web-App
 Wi-Fi System iControl mit web-App
 Sistema wi-fi iControl con web-App



ROOM CONTROL
Termostato ambiente wireless con supporto a muro
 Thermostat d'ambiance wireless avec support mural
 Room wireless Thermostat with its wall support
 Kabelloser Raumthermostat mit Wandhalterung
 Termostato de habitación wireless con su soporte de pared

Bianco

Tortora

Bordeaux

Matt Black

Idra 14	118
Idra 18 Evo	160
Idra 21	191

1135x565x648

Idra 14	5,3 - 13,7
Idra 18 Evo	5,4 - 18,9
Idra 21	5,3 - 22,5

Idra 14	5,1 - 13,1
Idra 18 Evo	5,3 - 17,8
Idra 21	5,1 - 21,2

Idra 14	3,8 - 10,9
Idra 18 Evo	3,7 - 15,0
Idra 21	3,8 - 17,9

Idra 14	1,1 - 2,8
Idra 18 Evo	1,1 - 3,9
Idra 21	1,1 - 4,6

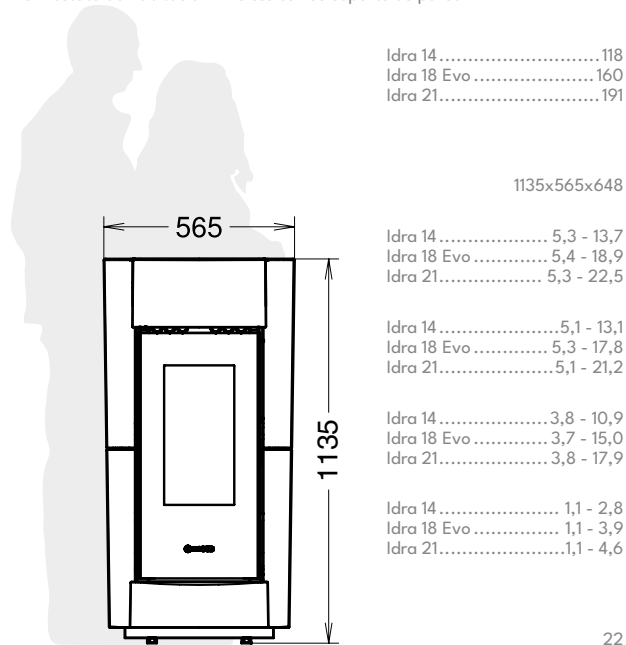

La tipologia di fiamma ed il focolare possono variare a seconda delle versioni
 Le type de flamme et le foyer peuvent varier selon les versions
 Flame and the firebox can vary according to different model



Advanced cleaning
PELLETPOWER®
 bruciatore brevettato

Up to
500 hours
 NO-STOP

Eco
 DESIGN
 2022

5
 STELLE
 DM 186/7

7
 ÉTOILES

BimSchV II



A⁺ A⁺⁺
↑
G



12kW natural air



12kW natural plus



CHIC supreme Evo6

- ITA Chic, la stufa a pellet dallo stile raffinato e senza tempo, per rendere la tua casa un luogo romantico ed elegante.
- FRA Chic, le poêle à granulés au style raffiné et intemporel, pour faire de votre maison un lieu romantique et élégant.
- ENG Chic, the pellet stove with a refined and timeless style, to make your home a romantic and elegant place.
- DEU Chic, der Pelletofen mit einem raffinierten und zeitlosen Stil, um Ihr Zuhause zu einem romantischen und eleganten Ort zu machen.
- ESP Chic, la estufa de pellets con un estilo refinado e intemporal, para hacer de su casa un lugar romántico y elegante.

**Uscite per canalizzazione disponibili:
due posteriori (a)**
Sorties de canalisation disponibles :
2 arrières (a)
Available ducting outlets: two rear (a)

**Accesso per il
caricamento del pellet**
Couverture pour le
chargement des granulés
Access for pellet loading

Schermo comandi programmabile
Panneau des commandes
programmable
Programmable control screen

**Top in cristallo con funzione
Natural a qualsiasi potenza**
Top en cristal avec fonction
Natural à tous les niveaux
de puissance
Crystal glass top with Natural
function at any power

**Vano scaldavivande
con piano in maiolica**
Compartment chauffe-plats
avec plateau en céramique
Food warming compartment
with majolica top

**Preziosa maiolica
artigianale fatta a mano**
Précieuses céramiques
artisanales faites à la main
Precious handmade majolica tiles

**Porta focolare in vetro
ceramico serigrafato e ghisa**
Porte de foyer en fonte et
cristal imprimé en sérigraphie
Screen-printed ceramic glass
and cast iron firebox door

OPTIONAL:



iCONTROL
Sistema wi-fi iControl con web-App
Système wi-fi iControl avec web-App
Wi-fi system iControl with web-App
Wi-Fi System iControl mit web-App
Sistema wi-fi iControl con web-App



ROOM CONTROL
Termostato ambiente wireless con supporto a muro
Thermostat d'ambiance wireless avec support mural
Room wireless Thermostat with its wall support
Kabelloser Raumthermostat mit Wandhalterung
Termostato de habitación wireless con su soporte de pared

Bianco

Tortora

Bordeaux

Matt
Black



102



1344x567x644



3,2 - 12,2



3,1 - 11,3



0,65 - 2,6



N.Air 29,5
N.Plus 26



CSTB BImSchV II
le futur en construction



(a) 16mx1
8mx2

(a) Solo per versione "Natural Plus" - Uniquement version "Natural Plus" - Only on "Natural Plus" version

La tipologia di fiamma ed il focolare possono variare a seconda delle versioni
Le type de flamme et le foyer peuvent varier selon les versions
Flame and the firebox can vary according to different model



supreme - 29kW idra



CHIC

supreme idra
idra 29 Evo

- ITA Chic, la stufa a pellet dallo stile raffinato e senza tempo, per rendere la tua casa un luogo romantico ed elegante.
- FRA Chic, le poêle à granulés au style raffiné et intemporel, pour faire de votre maison un lieu romantique et élégant.
- ENG Chic, the pellet stove with a refined and timeless style, to make your home a romantic and elegant place.
- DEU Chic, der Pelletofen mit einem raffinierten und zeitlosen Stil, um Ihr Zuhause zu einem romantischen und eleganten Ort zu machen.
- ESP Chic, la estufa de pellets con un estilo refinado e intemporal, para hacer de su casa un lugar romántico y elegante.



OPTIONAL:



INTEGRA TR-PACK
Thermocell® (250/400/500 lt)
Thermopuffer (400/500/1500 lt)
Thermosole® (2.0)



Thermofan:
Kit di ventilazione termostufa
Kit de ventilation thermo-poêle
Pellet thermo-stoves air convection kit
Raumlüftventilator für Pelletsofenwassergeführt
Pellet thermo-stoves kit de convection de aire



Valvola termostatica a 3 vie 1" FFF 55 OT (optional)
Vanne thermostatique 3 voies 1" FFF 55 OT (optional)
Thermostatic valve 3 ways 1" FFF 55 OT (optional)

Sonda PT100 (optional-min 2 pz) per funzione «THERMOCONTROL»
Sonde PT100 (optional-min 2 pces) pour fonction «THERMOCONTROL»
PT100 sensor (optional-min 2 pc) for «THERMOCONTROL» function;



iCONTROL
Sistema wi-fi iControl con web-App
Système wi-fi iControl avec web-App
Wi-fi system iControl with web-App
Wi-Fi System iControl mit web-App
Sistema wi-fi iControl con web-App



ROOM CONTROL
Termostato ambiente wireless con supporto a muro
Thermostat d'ambiance wireless avec support mural
Room wireless Thermostat with its wall support
Kabelloser Raumthermostat mit Wandhalterung
Termostato de habitación wireless con su soporte de pared

Bianco

Tortora

Bordeaux

Matt Black

Idra Supreme.....	203
Idra29Evo	213

1335x565x653

Idra Supreme.....	6,8 - 23,7
Idra29Evo	9,1 - 25,4

Idra Supreme.....	6,5 - 22,5
Idra29Evo	8,6 - 23,7

Idra Supreme.....	5,0 - 19,6
Idra29Evo	7,3 - 20,6

Idra Supreme.....	1,4 - 4,9
Idra29Evo	1,9 - 5,25

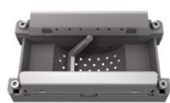
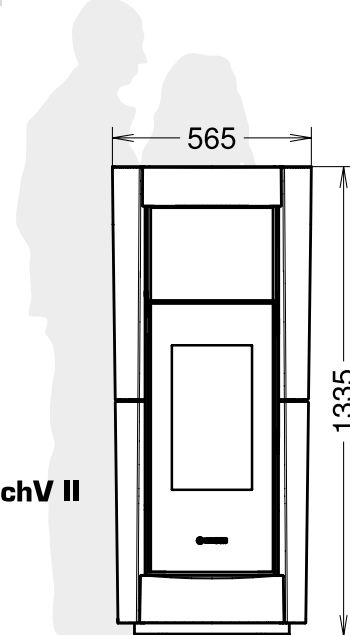

BlmSchV II



(a) Solo per versione "Idra29Evo" - Uniquement version "Idra29Evo" - Only on "Idra29Evo" version



	air
	plus
	12kW natural air
	12kW natural plus

DORICA Evo6

metalcolor

ITA Stufa a pellet dalle linee fluide e raccordate, sorprende al primo sguardo per la sua elegante architettura ispirata alla classicità. Dotata di bruciatore motorizzato con tecnologia PELLETPOWER® (modello Natural), scambiatore di calore THERMOCORE® e pulizia ordinaria e straordinaria semplificata EASY CLEANING.

FRA Poêle à granulés aux lignes fluides et raccordées, qui surprend au premier coup d'œil par son architecture élégante, inspirée au classicisme. Doté du brûleur motorisé avec technologie PELLETPOWER® (version Natural), de l'échangeur de chaleur THERMOCORE®, et du système de nettoyage ordinaire et extraordinaire simplifié EASY CLEANING.

ENG Pellet stove with flowing and joined lines, it is surprising at first sight for its elegant architecture inspired by the classics. Equipped with the motorised fan technology PELLETPOWER® (Natural model) heat exchanger THERMOCORE® and simplified cleaning system EASY CLEANING.

DEU Ausgestattet mit fließenden Linien ist dieser Pelletofen auf den ersten Blick sehr anmutend und überrascht mit einem eleganten Design, dass seinesgleichen sucht. Auch eine klassische Erscheinung mit Keramikverkleidung ist möglich. Ausgestattet mit einem Raumluftventilator, mit der PELLETPOWER® Technologie (nur Natural), dem Wärmetauscher THERMOCORE® und dem einfachen EASY CLEANING Reinigungssystem.

ESP Estufa de pellets con líneas fluidas y refinadas, que destaca a primera vista por su arquitectura elegante de inspiración clásica. Equipada con la tecnología de quemador motorizado. PELLETPOWER® (versión Natural), intercambiador de calor THERMOCORE® y limpieza ordinaria y extraordinaria simplificadas EASY CLEANING.

Uscite per canalizzazione disponibili:
due posteriori (c)

Sorties de canalisation disponibles : 2 arrières (c)
Available ducting outlets: two rear (c)

Schermo comandi
programmabile

Panneau des commandes
programmable
Programmable control screen

Preziosa maiolica
artigianale fatta a mano

Précieuses céramiques
artisanales faites à la main
Precious handmade majolica tiles

Top in cristallo con funzione
Natural a qualsiasi potenza (b)

Top en cristal avec fonction
Natural à tous les niveaux
de puissance (b)
Crystal glass top with Natural
function at any power (b)

Porta focolare in vetro
ceramico serigrafato e ghisa

Porte de foyer en fonte et
cristal imprimé en sérigraphie
Screen-printed ceramic glass
and cast iron firebox door

Bruciatore autopulente
brevettato Pelletpower® (b)

Brûleur autonettoyant
breveté Pelletpower® (b)
Pelletpower® patented
self-cleaning burner (b)

Piano salva cenere

Base ramasse-cendre
Protective ash pan

OPTIONAL:



iCONTROL

Sistema wi-fi iControl con web-App
Système wi-fi iControl avec web-App
Wi-fi system iControl with web-App
Wi-Fi System iControl mit web-App
Sistema wi-fi iControl con web-App



ROOM CONTROL

Termostato ambiente wireless con supporto a muro
Thermostat d'ambiance wireless avec support mural
Room wireless Thermostat with its wall support
Kabelloser Raumthermostat mit Wandhalterung
Termostato de habitación wireless con su soporte de pared

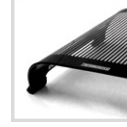

DINNER (a)

Coperchio scaldia vivande in cristallo
Couvercle chauffe-plat en cristal
Glass food-warming cover
Warmhalteplatte aus Kristallglas
Chapa para calentar comidas

(a) Solo per versione "Air - Plus" - Uniquement version "Air - Plus"
Only on "Air - Plus" version

Bianco

Beige

Tortora

Bordeaux

Grigio

Air/Plus 102
N.Air/N.Plus 12 102

Air 1114x560x645
Plus 1114x560x645
N.Air 12 1105x560x640
N.Plus 12 1105x560x640

Air/Plus 3,8 - 12,3
N.Air/N.Plus 12 3,2 - 12,2

Air/Plus 3,5 - 11,3
N.Air/N.Plus 12 3,1 - 11,3

Air/Plus 0,8 - 2,55
N.Air/N.Plus 12 0,65 - 2,6

Air 19
Plus 15
N.Air 12 20,7
N.Plus 12 17,2



(b) Advanced cleaning
PELLETPOWER®
bruciatore brevettato

Up to
500 hours
NO-STOP

Eco
DESIGN
2022

5
STELLE
DM 186/7

7
ÉTOILES

POLVERI (a)
7
mg/m³
13% di O₂

POLVERI (b)
9
mg/m³
13% di O₂

CSTB BlmSchV II
le futur en construction



(b)

(c) 16mx1
8mx2

(b)

(b)

(b)

(b) Solo per versione "Natural Air - Natural Plus" - Uniquement version "Natural Air - Natural Plus" - Only on "Natural Air - Natural Plus" version

(c) Solo per versione "Plus - Natural Plus" - Uniquement version "Plus - Natural Plus" - Only on "Plus - Natural Plus" version

La tipologia di fiamma ed il focolare possono variare a seconda delle versioni
Le type de flamme et le foyer peuvent varier selon les versions
Flame and the firebox can vary according to different model



14kW - 18kW - 21kW idra



DORICA idra metalcolor

ITA Stufa a pellet dalle linee fluide e raccordate, sorprende al primo sguardo per la sua elegante architettura ispirata alla classicità. Dotata di bruciatore motorizzato con tecnologia PELLETPOWER® (modello Natural), scambiatore di calore THERMOCORE® e pulizia ordinaria e straordinaria semplificata EASY CLEANING.

FRA Poêle à granulés aux lignes fluides et raccordées, qui surprend au premier coup d'œil par son architecture élégante, inspirée au classicisme. Doté du brûleur motorisé avec technologie PELLETPOWER® (version Natural), de l'échangeur de chaleur THERMOCORE®, et du système de nettoyage ordinaire et extraordinaire simplifié EASY CLEANING.

ENG Pellet stove with flowing and joined lines, it is surprising at first sight for its elegant architecture inspired by the classics. Equipped with the motorised fan technology PELLETPOWER® (Natural model) heat exchanger THERMOCORE® and simplified cleaning system EASY CLEANING.

DEU Ausgestattet mit fließenden Linien ist dieser Pelletofen auf den ersten Blick sehr anmutend und überrascht mit einem eleganten Design, dass seinesgleichen sucht. Auch eine klassische Erscheinung mit Keramikverkleidung ist möglich. Ausgestattet mit einem Raumlüftventilator, mit der PELLETPOWER® Technologie (nur Natural), dem Wärmetauscher THERMOCORE® und dem einfachen EASY CLEANING Reinigungssystem.

ESP Estufa de pellets con líneas fluidas y refinadas, que destaca a primera vista por su arquitectura elegante de inspiración clásica. Equipada con la tecnología de quemador motorizado. PELLETPOWER® (versión Natural), intercambiador de calor THERMOCORE® y limpieza ordinaria y extraordinaria simplificadas EASY CLEANING.



Schermo comandi programmabile
 Panneau des commandes programmable
 Programmable control screen

Accesso scorrevole per il caricamento del pellet
 Couvercle coulissant pour le chargement des granulés
 Sliding access for pellet loading

Preziosa maiolica artigianale fatta a mano
 Précieuses céramiques artisanales faites à la main
 Precious handmade majolica tiles

Porta focolare in vetro ceramico serigrafato e ghisa
 Porte de foyer en fonte et cristal imprimé en sérigraphie
 Screen-printed ceramic glass and cast iron firebox door

Briatore autopulente brevettato Pelletpower®
 Brûleur autonettoyant breveté Pelletpower®
 Pelletpower® patented self-cleaning burner

OPTIONAL:



INTEGRA TR-PACK
 Thermocell® (250/400/500 lt)
 Thermopuffer (400/500/1500 lt)
 Thermosole® (2.0)



Thermofan:
Kit di ventilazione termostufa
 Kit de ventilation thermo-poêle
 Pellet thermo-stoves air convection kit
 Raumluftventilator für Pelletsofenwassergeführt
 Pellet thermo-stoves kit de convection de aire



Valvola termostatica a 3 vie 1" FFF 55 OT (optional)
 Vanne thermostatique 3 voies 1" FFF 55 OT (optional)
 Thermostatic valve 3 ways 1" FFF 55 OT (optional)

Sonda PT100 (optional-min 2 pz) per funzione «THERMOCONTROL»
 Sonde PT100 (optional-min 2 pces) pour fonction «THERMOCONTROL»
 PT100 sensor (optional-min 2 pc) for «THERMOCONTROL» function



iCONTROL
Sistema wi-fi iControl con web-App
 Système wi-fi iControl avec web-App
 Wi-fi system iControl with web-App
 Wi-Fi System iControl mit web-App
 Sistema wi-fi iControl con web-App



ROOM CONTROL
Termostato ambiente wireless con supporto a muro
 Thermostat d'ambiance wireless avec support mural
 Room wireless Thermostat with its wall support
 Kabelloser Raumthermostat mit Wandhalterung
 Termostato de habitación wireless con su soporte de pared

Bianco

Beige

Tortora

Bordeaux

Grigio

Idra 14	118
Idra 18 Evo	160
Idra 21	191

1114x560x645

Idra 14	5,3 - 13,7
Idra 18 Evo	5,4 - 18,9
Idra 21	5,3 - 22,5

Idra 14	5,1 - 13,1
Idra 18 Evo	5,3 - 17,8
Idra 21	5,1 - 21,2

Idra 14	3,8 - 10,9
Idra 18 Evo	3,7 - 15,0
Idra 21	3,8 - 17,9

Idra 14	1,1 - 2,8
Idra 18 Evo	1,1 - 3,9
Idra 21	1,1 - 4,6

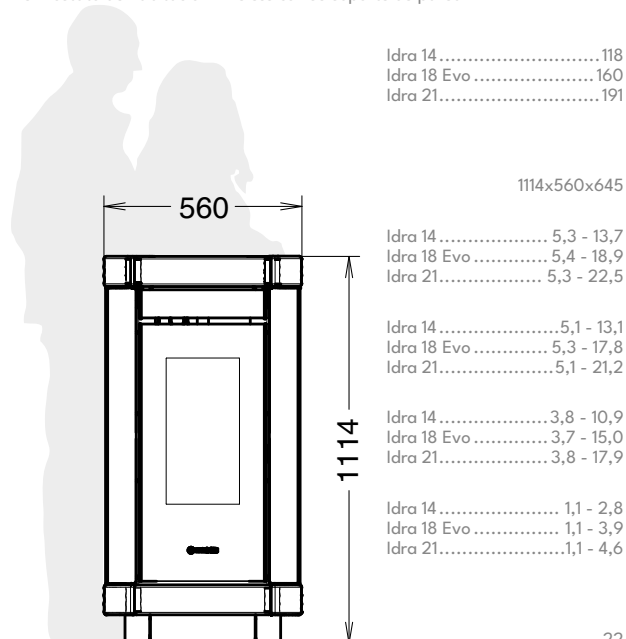

Advanced cleaning
PELLETPOWER®
 bruciatore brevettato

Up to
500 hours
 NO-STOP

Eco
 DESIGN
 2022

5
 STELLE
 DM 186/7

7
 ÉTOILES

BlmSchV II



La tipologia di fiamma ed il focolare possono variare a seconda delle versioni
 Le type de flamme et le foyer peuvent varier selon les versions
 Flame and the firebox can vary according to different model



12kW natural air

12kW natural plus

DORICA supreme Evo6

metalcolor

ITA Dorica Supreme, colonna di fuoco dalla linea sobria e scolpita grazie all'alternanza dei materiali utilizzati come il cristallo nero e l'acciaio laccato con finiture in maiolica. L'innovativo sistema di accesso al serbatoio, attraverso lo scorrimento del coperchio superiore, garantisce un elegante e raffinato design. Ideale per chi vuole distribuire il calore in ambienti diversi e riscaldare più locali, basta un semplice gesto per gestire il flusso dell'aria verso le canalizzazioni. Due canalizzazioni, indipendenti l'una dall'altra con la possibilità di gestire entrambi i flussi separatamente con la massima flessibilità. Dotata del pratico scaldavivande in maiolica, igienico e di facile pulizia.

FRA Dorica Supreme, colonne de feu à la ligne sobre et sculptée, grâce à l'alternance des matériaux utilisés, comme le cristal noir ou l'acier laqué avec finitions en majolique. Idéal pour qui désire distribuer l'air chaud dans des pièces différentes et réchauffer divers locaux. Un simple geste suffit pour adresser le flux de l'air vers les canalisations. Deux canalisations indépendantes, pour avoir la possibilité de gérer les flux indépendamment et avec la plus grande flexibilité. Doté d'un chauffe-plats coulissant en majolique, pratique, hygiénique et simple à nettoyer.

ENG Dorica Supreme, column of fire, classical line carved by the strength of raw materials, black glass and painted steel with finishes in majolica. The innovative sliding top access to the fuel tank enhances its many other attractive features. If you would like a ducted hot air supply into several rooms the Dorica Plus provides an ideal solution. It is possible to warm different spaces quickly and easily via an intuitive control system designed to distribute hot air into the ducting system. The twin air ducting system is designed to provide independent outlets which are both able to share air the flow with maximum flexibility. Equipped with the practical, hygienic and easy to clean hot plate in majolica.

DEU Dorica Supreme, Feuersäule mit einer modellierten und mäßigen Linien, danke auf die benutzte Materialien wie die schwarze Glas und lackiertem Stahl mit Oberflächen in Majolika. Das innovative System für den Zugang zum Tank, durch die obere Abdeckung, bietet eine elegante und raffinierte Design. Ideal für diejenigen, die Wärme in verschiedenen Umgebungen verteilt möchten, um sie zu heizen, nur eine einfache Geste, um das Strömen von Luft in den Kanalisierungen zu verwalten. Zwei Kanalisierungen, unabhängig voneinander, mit der Möglichkeit, die Ströme in unabhängiger Weise zu verwalten und mit der maximalen Flexibilität. Ausgestattet mit einer hygienischen Warmhaltefläche aus Majolika, einfach zu reinigen.

ESP Dorica Supreme, columna de fuego de línea sobria y esculpida con alternancia de materiales: cristal negro y acero pintado con acabados en majolika. Ideal para quien quiere distribuir el calor en varias habitaciones; de manera muy sencilla permite gestionar el flujo de aire a través de la canalización. Dos canalizaciones, independientes la una de la otra con posibilidad de gestionar los flujos de aire con la máxima flexibilidad. Equipada con un práctico plano para calentar comidas hecho en majolika higiénica y fácil de limpiar.



**Uscite per canalizzazione disponibili:
due posteriori (a)**
Sorties de canalisation disponibles :
2 arrières (a)
Available ducting outlets: two rear (a)

**Accesso per il
caricamento del pellet**
Couvercle pour le
chargement des granulés
Access for pellet loading

Schermo comandi programmabile
Panneau des commandes
programmable
Programmable control screen

**Preziosa maiolica
artigianale fatta a mano**
Précieuses céramiques
artisanales faites à la main
Precious handmade majolica tiles

**Top in cristallo con funzione
Natural a qualsiasi potenza**
Top en cristal avec fonction Natural
à tous les niveaux de puissance
Crystal glass top with
Natural function at any power

**Vano scaldavivande
con piano in ceramica**
Compartment chauffe-plats
avec plateau en céramique
Food warming compartment
with majolica top

**Porta focolare in vetro
ceramico serigrafato e ghisa**
Porte de foyer en fonte et
cristal imprimé en sérigraphie
Screen-printed ceramic glass
and cast iron firebox door

OPTIONAL:



iCONTROL
Sistema wi-fi iControl con web-App
Système wi-fi iControl avec web-App
Wi-fi system iControl with web-App
Wi-Fi System iControl mit web-App
Sistema wi-fi iControl con web-App



ROOM CONTROL
Termostato ambiente wireless con supporto a muro
Thermostat d'ambiance wireless avec support mural
Room wireless Thermostat with its wall support
Kabelloser Raumthermostat mit Wandhalterung
Termostato de habitación wireless con su soporte de pared

Bianco



Beige



Tortora



Bordeaux



Grigio



102



1317x560x641



3,2 - 12,2



3,1 - 11,3



0,65 - 2,6



N.Air 29,5
N.Plus 26



Advanced cleaning
PELLETPOWER®
bruciatore brevettato

Up to
500 hours
NO-STOP

Eco
DESIGN
2022

5
STELLE
DM 186/7

7
ÉTOILES

POLVERI
9
mg/m³
13% di O₂

CSTB **BImSchV II**
le futur en construction



(a) 16mx1
8mx2

(a) Solo per versione "Natural Plus" - Uniquement version "Natural Plus" - Only on "Natural Plus" version

La tipologia di fiamma ed il focolare possono variare a seconda delle versioni
Le type de flamme et le foyer peuvent varier selon les versions
Flame and the firebox can vary according to different model



supreme - 29kW idra



DORICA supreme idra metalcolor idra 29 Evo

- ITA Dorica Supreme, colonna di fuoco dalla linea sobria e scolpita grazie all'alternanza dei materiali utilizzati come il cristallo nero e la maiolica. L'innovativo sistema di accesso al serbatoio, attraverso lo scorrimento del coperchio superiore, garantisce un elegante e raffinato design. Il design Dorica® Supreme si arricchisce nella versione idra con un nuovo modello ancora più potente, ideale per il riscaldamento domestico diventa il cuore dell'impianto. L'innovativo bruciatore motorizzato con tecnologia brevettata PELLETPOWER® mantiene la resa termica elevata e costante nell'arco dell'intera giornata: mantenere il bruciatore pulito significa ridurre sia la manutenzione ordinaria che i costi di combustibile, con un rapido ammortamento del generatore.
- FRA Dorica Supreme, colonne de feu à la ligne sobre et sculptée, grâce à l'alternance des matériaux utilisés, comme le cristal noir et la céramique. L'innovant système d'accès au réservoir à granulés par coulissement du couvercle supérieur garantit un design élégant et raffiné. Le très design Dorica® Supreme s'enrichit dans sa version Idra d'un nouveau modèle encore plus puissant. Idéal pour le chauffage domestique, il devient le cœur du circuit. L'innovant brûleur motorisé avec technologie brevetée PELLETPOWER® maintient le rendement thermique élevé et constant tout au long du jour : garder le brûleur propre signifie réduire aussi bien la manutention ordinaire que les frais de combustible, avec un amortissement plus rapide du générateur.
- ENG Dorica Supreme, column of fire, classically shaped by the power of the raw materials, black glass and majolica. The innovative sliding top access to the fuel tank enhances its many other attractive features. The Dorica® designed collection enhances itself with the entry of a new idra version. If you would like to heat domestic environment through a pellet-heating generator, it provides the ideal solution and it becomes the core of the system. The PELLETPOWER® innovative patented burner maintains the correct rate of oxygen keeping the efficiency of combustion stable for longer periods: keeping the burner clean means reducing cleaning times and fuel costs, and payback initial heating-generator costs over few years.
- DEU Dorica Supreme mit Majolikakacheln ist eine Feuersäule welche dank seiner klassisch gerillten Form und einer Schwarzglasfront überzeugt. Das innovative Befüllungssystem des Pellettanks mittels Schiebemechanismus verbindet eine einfache Pelletbefüllung mit elegantem und raffiniertem Design. Die Dorica® Familie, wird nun mit einem neuen wassergeführten Modell erweitert, welches noch leistungsfähiger ist. Wenn Sie eine größere Fläche durch eine Pellet-Heizung erwärmen möchten, bietet dieses Produkt die ideale Lösung. Es bildet den Kern des Heizsystems welches dank seiner kompakten Abmessungen einfach im Wohnbereich integriert werden kann. PELLETPOWER® das innovative patentierte Brennersystem hält den Sauerstoffgehalt bei der Verbrennung konstant und hält die Effizienz der Verbrennung für einen langen Zeitraum stabil. Der Brenner wird konstant saubergehalten und somit reduzieren sich die Brennstoffkosten und die Amortisation des Heizgerätes über viele Jahre.
- ESP Dorica Supreme, columna de fuego de línea sobria y esculpida gracias a la alternancia de materiales: cristal negro y cerámica. El Design Dorica® Supreme se enriquece en la versión idra con un nuevo modelo, aún más potente. Ideal para la calefacción del hogar, se convierte en el centro de la instalación integrandose fácilmente gracias a sus opciones tecnológicas. El quemador motorizado con tecnología patentada PELLETPOWER® mantiene constantemente una alta eficiencia térmica durante todo el día: mantener limpio el quemador quiere decir reducir tanto el mantenimiento como los gastos de combustible, con una rápida amortización del generador.

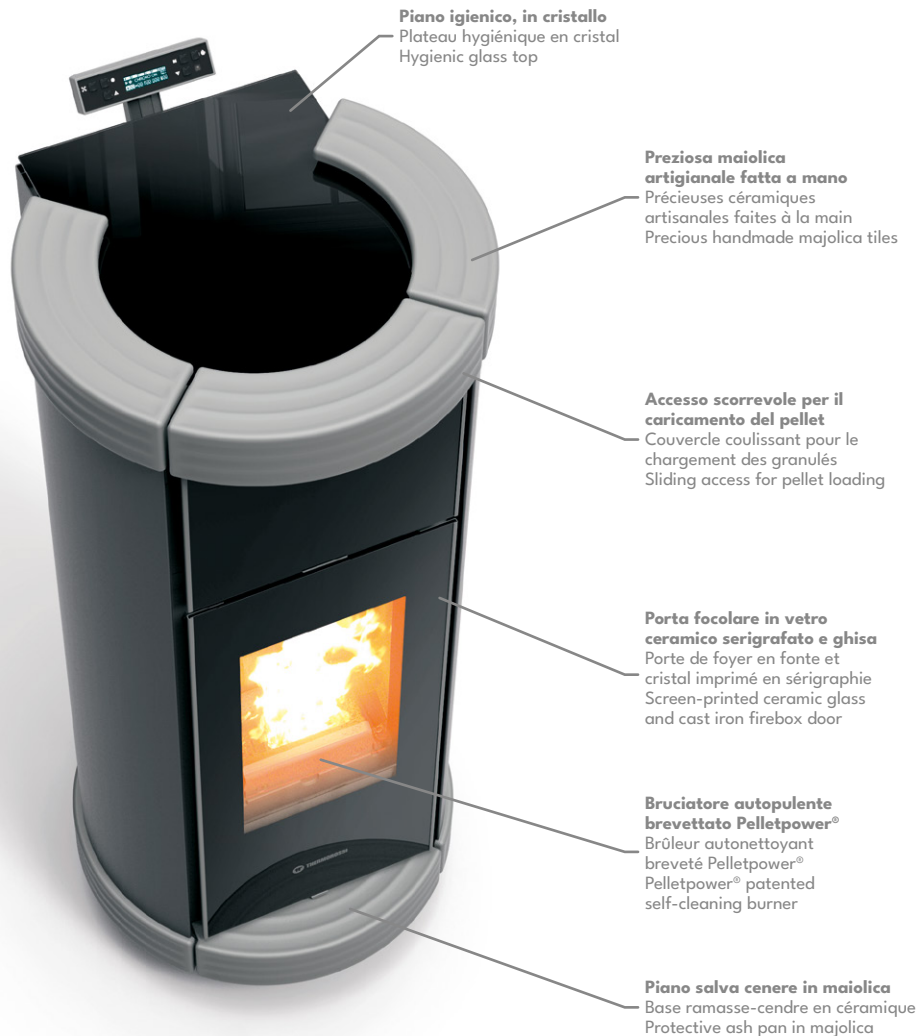

OPTIONAL:



INTEGRA TR-PACK
Thermocell® (250/400/500 lt)
Thermopuffer (400/500/1500 lt)
Thermosole® (2.0)



Thermofan:
Kit di ventilazione termostufa
Kit de ventilation thermo-poêle
Pellet thermo-stoves air convection kit
Raumlüftventilator für Pelletsofenwassergeführt
Pellet thermo-stoves kit de convection de aire



Valvola termostatica a 3 vie 1" FFF 55 OT (optional)
Vanne thermostatique 3 voies 1" FFF 55 OT (optional)
Thermostatic valve 3 ways 1" FFF 55 OT (optional)

Sonda PT100 (optional-min 2 pz) per funzione «THERMOCONTROL»
Sonde PT100 (optional-min 2 pces) pour fonction «THERMOCONTROL»
PT100 sensor (optional-min 2 pc) for «THERMOCONTROL» function



iCONTROL
Sistema wi-fi iControl con web-App
Système wi-fi iControl avec web-App
Wi-fi system iControl with web-App
Wi-Fi System iControl mit web-App
Sistema wi-fi iControl con web-App



ROOM CONTROL
Termostato ambiente wireless con supporto a muro
Thermostat d'ambiance wireless avec support mural
Room wireless Thermostat with its wall support
Kabelloser Raumthermostat mit Wandhalterung
Termostato de habitación wireless con su soporte de pared

Bianco

Beige

Tortora

Bordeaux

Grigio

Idra Supreme..... 203
Idra29Evo 213

1321x560x650

Idra Supreme..... 6,8 - 23,7
Idra29Evo 9,1 - 25,4

Idra Supreme..... 6,5 - 22,5
Idra29Evo 8,6 - 23,7

Idra Supreme..... 5,0 - 19,6
Idra29Evo 7,3 - 20,6

Idra Supreme..... 1,4 - 4,9
Idra29Evo 1,9 - 5,25

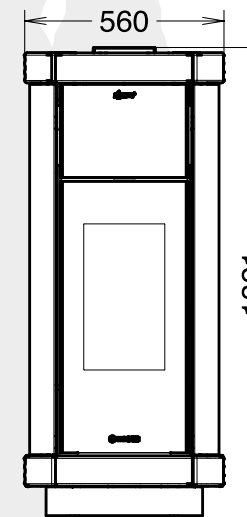

Advanced cleaning
PELLETPOWER®
bruciatore brevettato

Up to
500 hours
NO-STOP



(a) **5 STELLE**
DM 186/7

(a) **7 ÉTOILES**

(a) **POLVERI**
9 mg/m³
13% di O₂

BlmSchV II



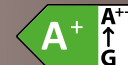

	air
	plus
	12kW natural air
	12kW natural plus

DORICA Evo6

maiolica

ITA Stufa a pellet dalle linee fluide e raccordate, sorprende al primo sguardo per la sua elegante architettura ispirata alla classicità. Dotata di bruciatore motorizzato con tecnologia PELLETPOWER® (modello Natural), scambiatore di calore THERMOCORE® e pulizia ordinaria e straordinaria semplificata EASY CLEANING.

FRA Poêle à granulés aux lignes fluides et raccordées, qui surprend au premier coup d'œil par son architecture élégante, inspirée au classicisme. Doté du brûleur motorisé avec technologie PELLETPOWER® (version Natural), de l'échangeur de chaleur THERMOCORE®, et du système de nettoyage ordinaire et extraordinaire simplifié EASY CLEANING.

ENG Pellet stove with flowing and joined lines, it is surprising at first sight for its elegant architecture inspired by the classics. Equipped with the motorised fan technology PELLETPOWER® (Natural model) heat exchanger THERMOCORE® and simplified cleaning system EASY CLEANING.

DEU Ausgestattet mit fließenden Linien ist dieser Pelletofen auf den ersten Blick sehr anmutend und überrascht mit einem eleganten Design, dass seinesgleichen sucht. Auch eine klassische Erscheinung mit Keramikverkleidung ist möglich. Ausgestattet mit einem Raumlüftventilator, mit der PELLETPOWER® Technologie (nur Natural), dem Wärmetauscher THERMOCORE® und dem einfachen EASY CLEANING Reinigungssystem.

ESP Estufa de pellets con líneas fluidas y refinadas, que destaca a primera vista por su arquitectura elegante de inspiración clásica. Equipada con la tecnología de quemador motorizado. PELLETPOWER® (versión Natural), intercambiador de calor THERMOCORE® y limpieza ordinaria y extraordinaria simplificadas EASY CLEANING.

Uscite per canalizzazione disponibili:
due posteriori (c)

Sorties de canalisation disponibles : 2 arrières (c)
Available ducting outlets: two rear (c)

Schermo comandi
programmabile
Panneau des commandes
programmable
Programmable control screen

Preziosa maiolica
artigianale fatta a mano
Précieuses céramiques
artisanales faites à la main
Precious handmade majolica tiles

Top in cristallo con funzione
Natural a qualsiasi potenza (b)
Top en cristal avec fonction
Natural à tous les niveaux
de puissance (b)
Crystal glass top with Natural
function at any power (b)

Porta focolare in vetro
ceramico serigrafato e ghisa
Porte de foyer en fonte et
cristal imprimé en sérigraphie
Screen-printed ceramic glass
and cast iron firebox door

Bruciatore autopulente
brevettato Pelletpower® (b)
Brûleur autonettoyant
breveté Pelletpower® (b)
Pelletpower® patented
self-cleaning burner (b)

Piano salva cenere
Base ramasse-cendre
Protective ash pan

OPTIONAL:



iCONTROL
Sistema wi-fi iControl con web-App
Système wi-fi iControl avec web-App
Wi-fi system iControl with web-App
Wi-Fi System iControl mit web-App
Sistema wi-fi iControl con web-App



ROOM CONTROL
Termostato ambiente wireless con supporto a muro
Thermostat d'ambiance wireless avec support mural
Room wireless Thermostat with its wall support
Kabelloser Raumthermostat mit Wandhalterung
Termostato de habitación wireless con su soporte de pared

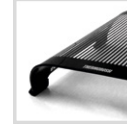

DINNER (a)
Coperchio scaldia vivande in cristallo
Couvercle chauffe-plat en cristal
Glass food-warming cover
Warmhalteplatte aus Kristallglas
Chapa para calentar comidas

(a) Solo per versione "Air - Plus" - Uniquement version "Air - Plus"
Only on "Air - Plus" version



Dorica Stone

Preziosa pietra ollare
Precious soapstone
Précieuse pierre ollaire

Bianco



Beige



Tortora



Bordeaux



Nero



Stone



Air/Plus 102
N.Air/N.Plus 12 102

Air 1114x560x645
Plus 1114x560x645
N.Air 12 1105x560x640
N.Plus 12 1105x560x640

Air 1123x560x644
Dorica Plus 1123x560x644
Stone N.Air 12 1105x560x640
N.Plus 12 1105x560x640

Air/Plus 3,8 - 12,3
N.Air/N.Plus 12 3,2 - 12,2

Air/Plus 3,5 - 11,3
N.Air/N.Plus 12 3,1 - 11,3

Air/Plus 0,8 - 2,55
N.Air/N.Plus 12 0,65 - 2,6

Air 19
Plus 15
N.Air 12 20,7
N.Plus 12 17,2



(b) Advanced cleaning
PELLETPOWER®
bruciatore brevettato

Up to
500 hours
NO-STOP

Eco
DESIGN
2022

5
STELLE
DM 186/7

7
ÉTOILES

POLVERI (a)
7
mg/m³
13% di O₂

POLVERI (b)
9
mg/m³
13% di O₂

CSTB BlmSchV II
le futur en construction



(b)

(c) 16mx1
8mx2

(b)

(b)

(b) Solo per versione "Natural Air - Natural Plus" - Uniquement version "Natural Air - Natural Plus" - Only on "Natural Air - Natural Plus" version
(c) Solo per versione "Plus - Natural Plus" - Uniquement version "Plus - Natural Plus" - Only on "Plus - Natural Plus" version

La tipologia di fiamma ed il focolare possono variare a seconda delle versioni
Le type de flamme et le foyer peuvent varier selon les versions
Flame and the firebox can vary according to different model

A+ A++
↑
G



14kW - 18kW - 21kW idra



DORICA idra stone

ITA Fatti affascinare dalle venature della pietra, impreziosisci la tua casa con un materiale naturale, unico, materico e sensoriale.

FRA Laissez-vous séduire par les veines de la pierre, et embellissez votre maison grâce à un matériau naturel, unique et sensoriel.

ENG Let yourself be conquered by the veining of the stone, enhance your home with a natural, unique, and sensory material.

DEU Lassen Sie sich von der Maserung des Steins faszinieren, Ihr Zuhause mit einem natürlichen, einzigartigen, sensorischen Material zu verschönern.

ESP Déjese fascinar por las venas de la piedra, y embellece la casa con un material natural, único y sensorial.

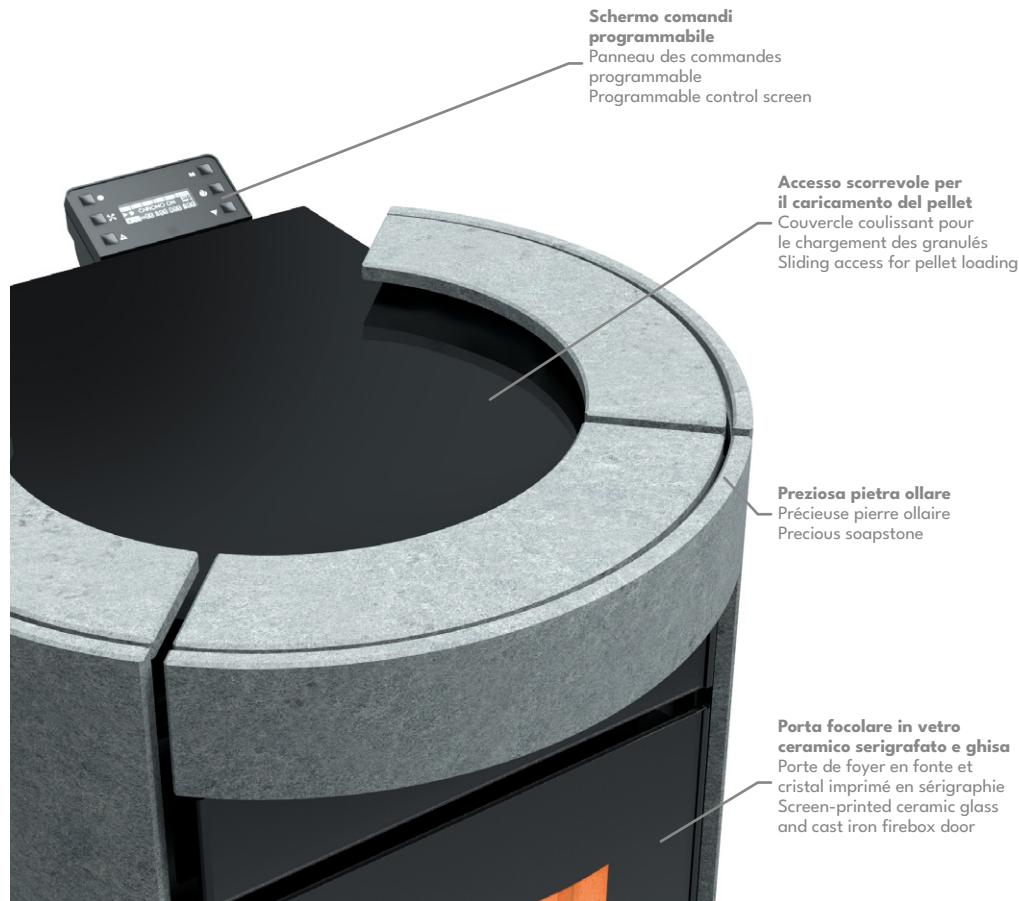

Schermo comandi programmabile
 Panneau des commandes programmable
 Programmable control screen

Accesso scorrevole per il caricamento del pellet
 Couverture coulissante pour le chargement des granulés
 Sliding access for pellet loading

Preziosa pietra ollare
 Précieuse pierre ollaire
 Precious soapstone

Porta focolare in vetro ceramico serigrafato e ghisa
 Porte de foyer en fonte et cristal imprimé en sérigraphie
 Screen-printed ceramic glass and cast iron firebox door

OPTIONAL:



INTEGRA TR-PACK
 Thermocell® (250/400/500 lt)
 Thermopuffer (400/500/1500 lt)
 Thermosole® (2.0)



Thermofan:
Kit di ventilazione termostufa
 Kit de ventilation thermo-poêle
 Pellet thermo-stoves air convection kit
 Raumluftventilator für Pelletsofenwassergeführt
 Pellet thermo-stoves kit de convection de aire



Valvola termostatica a 3 vie 1" FFF 55 OT (optional)
 Vanne thermostatique 3 voies 1" FFF 55 OT (optional)
 Thermostatic valve 3 ways 1" FFF 55 OT (optional)



Sonda PT100 (optional-min 2 pz) per funzione «THERMOCONTROL»
 Sonde PT100 (optional-min 2 pces) pour fonction «THERMOCONTROL»
 PT100 sensor (optional-min 2 pc) for «THERMOCONTROL» function



iCONTROL
Sistema wi-fi iControl con web-App
 Système wi-fi iControl avec web-App
 Wi-fi system iControl with web-App
 Wi-Fi System iControl with web-App
 Sistema wi-fi iControl con web-App



ROOM CONTROL
Termostato ambiente wireless con supporto a muro
 Thermostat d'ambiance wireless avec support mural
 Room wireless Thermostat with its wall support
 Kabelloser Raumthermostat mit Wandhalterung
 Termostato de habitación wireless con su soporte de pared

Bianco



Beige



Tortora



Bordeaux



Nero



Stone



Ildra 14	118
Ildra 18 Evo	160
Ildra 21	191

1119x560x644

Ildra 14	5,3 - 13,7
Ildra 18 Evo	5,4 - 18,9
Ildra 21	5,3 - 22,5

Ildra 14	5,1 - 13,1
Ildra 18 Evo	5,3 - 17,8
Ildra 21	5,1 - 21,2

Ildra 14	3,8 - 10,9
Ildra 18 Evo	3,7 - 15,0
Ildra 21	3,8 - 17,9

Ildra 14	1,1 - 2,8
Ildra 18 Evo	1,1 - 3,9
Ildra 21	1,1 - 4,6

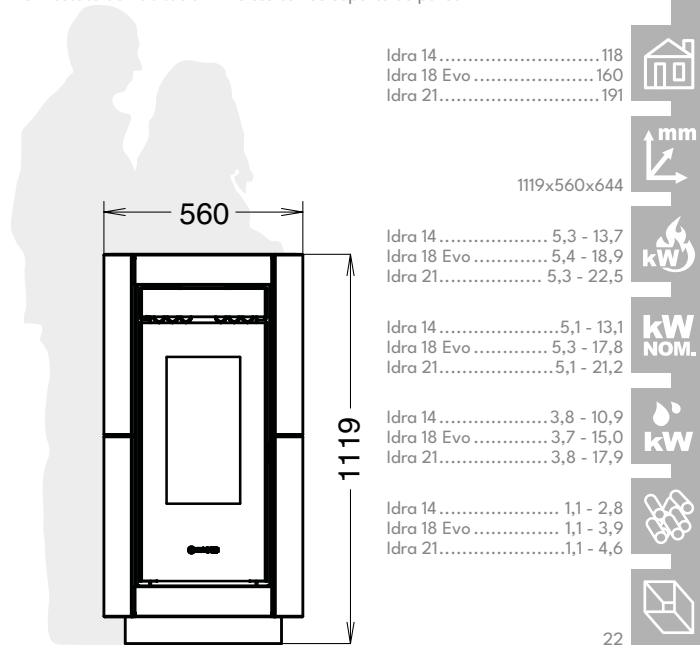

La tipologia di fiamma ed il focolare possono variare a seconda delle versioni
 Le type de flamme et le foyer peuvent varier selon les versions
 Flame and the firebox can vary according to different model



Advanced cleaning
PELLETPOWER®
 bruciatore brevettato

Up to
500 hours
 NO-STOP

Eco
 DESIGN
 2022

5
 STELLE
 DM 186/7

7
 ÉTOILES

BlmSchV II





12kW natural air

12kW natural plus

DORICA supreme Evo6 maiolica



ITA Dorica Supreme, colonna di fuoco dalla linea sobria e scolpita grazie all'alternanza dei materiali utilizzati come il cristallo nero e la maiolica. L'innovativo sistema di accesso al serbatoio, attraverso lo scorrimento del coperchio superiore, garantisce un elegante e raffinato design. Ideale per chi vuole distribuire il calore in ambienti diversi e riscaldare più locali, basta un semplice gesto per gestire il flusso dell'aria verso le canalizzazioni. Due canalizzazioni, indipendenti l'una dall'altra con la possibilità di gestire entrambi i flussi separatamente con la massima flessibilità. Dotata del pratico scaldavivande in maiolica, igienico e di facile pulizia.

FRA Dorica Supreme, colonne de feu à la ligne sobre et sculptée, grâce à l'alternance des matériaux utilisés, comme le cristal noir ou la céramique. Idéal pour qui désire distribuer l'air chaud dans des pièces différentes et réchauffer divers locaux. Un simple geste suffit pour adresser le flux de l'air vers les canalisations. Deux canalisations indépendantes, pour avoir la possibilité de gérer les flux indépendamment et avec la plus grande flexibilité. Doté d'un chauffe-plats en majolica, pratique, hygiénique et simple à nettoyer.

ENG Dorica Supreme, column of fire, classical line carved by the strength of raw materials, black glass and majolica. The innovative sliding top access to the fuel tank enhances its many other attractive features. If you would like a ducted hot air supply into several rooms the Dorica Plus provides an ideal solution. It is possible to warm different spaces quickly and easily via an intuitive control system designed to distribute hot air into the ducting system. The twin air ducting system is designed to provide independent outlets which are both able to share air the flow with maximum flexibility. Equipped with the practical, hygienic and easy to clean hot plate in majolica.

DEU Dorica Supreme, Feuersäule mit einer modellierten und mäßige Linien, danke auf die benutzte Materiale wie die schwarze Glass und Steingut. Das innovative System für den Zugang zum Tank, durch die obere Abdeckung, bietet eine elegante und raffinierte Design. Ideal für diejenigen, die die Wärme in verschiedenen Umgebungen verteilt möchten, um sie zu heizen, nur eine einfache Geste, um das Strömen von Luft in den Kanalisierungen zu verwalten. Zwei Kanalisierungs, unabhängig voneinander, mit der Möglichkeit, die Ströme in unabhängiger Weise zu verwalten und mit der maximalen Flexibilität. Ausgestattet mit einer hygienischen Warmhaltefläche aus Majolica, einfach zu reinigen.

ESP Dorica Supreme, columna de fuego de línea sobria y esculpida con alternancia de materiales: cristal negro y cerámica. Ideal para quien quiere distribuir el calor en varias habitaciones; de manera muy sencilla permite gestionar el flujo de aire a través de la canalización. Dos canalizaciones, independientes la una de la otra con posibilidad de gestionar los flujos de aire con la máxima flexibilidad. Equipada con un práctico plano para calentar comidas hecho en majolica higiénica y fácil de limpiar.

**Uscite per canalizzazione disponibili:
due posteriori (a)**
Sorties de canalisation disponibles :
2 arrières (a)
Available ducting outlets: two rear (a)

**Accesso per il
caricamento del pellet**
Couvercle pour le
chargement des granulés
Access for pellet loading

Schermo comandi programmabile
Panneau des commandes
programmable
Programmable control screen

**Preziosa maiolica
artigianale fatta a mano**
Précieuses céramiques
artisanales faites à la main
Precious handmade majolica tiles

**Top in cristallo con funzione
Natural a qualsiasi potenza**
Top en cristal avec fonction
Natural à tous les niveaux de puissance
Crystal glass top with
Natural function at any power

**Vano scaldavivande
con piano in ceramica**
Compartment chauffe-plats
avec plateau en céramique
Food warming compartment
with majolica top

**Porta focolare in vetro
ceramico serigrafato e ghisa**
Porte de foyer en fonte et
cristal imprimé en sérigraphie
Screen-printed ceramic glass
and cast iron firebox door

OPTIONAL:



iCONTROL
Sistema wi-fi iControl con web-App
Système wi-fi iControl avec web-App
Wi-fi system iControl with web-App
Wi-Fi System iControl mit web-App
Sistema wi-fi iControl con web-App



ROOM CONTROL
Termostato ambiente wireless con supporto a muro
Thermostat d'ambiance wireless avec support mural
Room wireless Thermostat with its wall support
Kabelloser Raumthermostat mit Wandhalterung
Termostato de habitación wireless con su soporte de pared



**Dorica Supreme
Stone**

Preziosa pietra ollare
Précieuse pierre ollaire
Precious soapstone

Bianco

Beige

Tortora

Bordeaux

Stone



102



1318x560x641



3,2 - 12,2



3,1 - 11,3



0,65 - 2,6



N.Air 29,5
N.Plus 26



**Advanced cleaning
PELLETPOWER®**
bruciatore brevettato

**Up to
500 hours
NO-STOP**

**Eco
DESIGN
2022**

**5
STELLE
DM 186/7**

**7
ÉTOILES**

**POLVERI
9
mg/m³
13% di O₂**

CSTB BImSchV II
le futur en construction



(a) 16mx1
8mx2

(a) Solo per versione "Natural Plus" - Uniquement version "Natural Plus" - Only on "Natural Plus" version

La tipologia di fiamma ed il focolare possono variare a seconda delle versioni
Le type de flamme et le foyer peuvent varier selon les versions
Flame and the firebox can vary according to different model



supreme - 29kW idra



DORICA

supreme idra stone
idra 29 Evo

- ITA Fatti affascinare dalle venature della pietra, impreziosisci la tua casa con un materiale naturale, unico, materico e sensoriale.
- FRA Laissez-vous séduire par les veines de la pierre, et embellissez votre maison grâce à un matériau naturel, unique et sensoriel.
- ENG Let yourself be conquered by the veining of the stone, enhance your home with a natural, unique, and sensory material.
- DEU Lassen Sie sich von der Maserung des Steins faszinieren, Ihr Zuhause mit einem natürlichen, einzigartigen, sensorischen Material zu verschönern.
- ESP Déjese fascinar por las venas de la piedra, y embellece la casa con un material natural, único y sensorial.



OPTIONAL:



INTEGRA TR-PACK
Thermocell® (250/400/500 lt)
Thermopuffer (400/500/1500 lt)
Thermosole® (2.0)



Thermofan:
Kit di ventilazione termostufa
Kit de ventilation thermo-poêle
Pellet thermo-stoves air convection kit
Raumlüftventilator für Pelletsofenwassergeführt
Pellet thermo-stoves kit de convection de aire



Valvola termostatica a 3 vie 1" FFF 55 OT (optional)
Vanne thermostatique 3 voies 1" FFF 55 OT (optional)
Thermostatic valve 3 ways 1" FFF 55 OT (optional)

Sonda PT100 (optional-min 2 pz) per funzione «THERMOCONTROL»
Sonde PT100 (optional-min 2 pces) pour fonction «THERMOCONTROL»
PT100 sensor (optional-min 2 pc) for «THERMOCONTROL» function



iCONTROL
Sistema wi-fi iControl con web-App
Système wi-fi iControl avec web-App
Wi-fi system iControl with web-App
Wi-Fi System iControl mit web-App
Sistema wi-fi iControl con web-App



ROOM CONTROL
Termostato ambiente wireless con supporto a muro
Thermostat d'ambiance wireless avec support mural
Room wireless Thermostat with its wall support
Kabelloser Raumthermostat mit Wandhalterung
Termostato de habitación wireless con su soporte de pared

Dorica Supreme
Idra Maiolica

Preziosa maiolica artigianale fatta a mano
Précieuses céramiques artisanales faites à la main
Precious handmade majolica tiles



Idra Supreme..... 203
Idra29Evo 213

1321x560x650

Idra Supreme..... 6,8 - 23,7
Idra29Evo 9,1 - 25,4

Idra Supreme..... 6,5 - 22,5
Idra29Evo 8,6 - 23,7

Idra Supreme..... 5,0 - 19,6
Idra29Evo 7,3 - 20,6

Idra Supreme..... 1,4 - 4,9
Idra29Evo 1,9 - 5,25

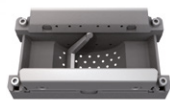

Advanced cleaning
PELLETPOWER®
bruciatore brevettato

Up to
500 hours
NO-STOP

Eco
DESIGN
2022

(a) **5**
STELLE
DM 186/7

(a) **7**
ÉTOILES

(a) **POLVERI**
9
mg/m³
13% di O₂

BlmSchV II



(a) Solo per versione "Idra29Evo" - Uniquement version "Idra29Evo" - Only on "Idra29Evo" version



Stufa con rivestimento stone assemblato
 Poêle avec kit habillage en pierre assemblé
 Stove with coating kit in soapstone assembled
 Ofen mit Sandstein-Verkleidungsset montiert
 Estufa con revestimiento en piedra ensamblado

product protected by design and innovation patent



	air plus
	12kW natural air
	12kW natural plus

ESSENZA Evo6

stone

ITA Stufa a pellet dal design essenziale e minimalista, rivestita in pietra ollare oppure in acciaio colorato arricchita da una maiolica per diffondere essenze aromatiche. Dotata di bruciatore motorizzato con tecnologia PELLETPOWER® (modello Natural), scambiatore di calore THERMOCORE® e pulizia ordinaria e straordinaria semplificata EASY CLEANING.

FRA Poêle à granulés au design essentiel et minimaliste, habillé en pierre ollaire ou en acier coloré, enrichi d'une céramique pour la diffusion d'essences aromatiques. Doté d'un brûleur motorisé avec technologie PELLETPOWER® (version Natural), de l'échangeur de chaleur THERMOCORE®, et du système de nettoyage ordinaire et extraordinaire simplifié EASY CLEANING.

ENG Pellet stove with an essential and minimalist design, clad in soapstone or coloured steel embellished with aromatic essential oils. Equipped with the motorised fan technology PELLETPOWER® (Natural model) heat exchanger THERMOCORE® and simplified cleaning system EASY CLEANING.

DEU Der Pelletofen mit geradlinigem und minimalistischem Design, verkleidet mit Sandstein oder farbigen Stahl und einer Duftschaale für aromatische Raumduftöle, wird Sie begeistern. Ausgestattet mit einem Raumlüftventilator, mit der PELLETPOWER® Technologie (nur Natural), dem Wärmetauscher THERMOCORE® und dem einfachen EASY CLEANING Reinigungssystem.

ESP Estufa de pellets de diseño esencial y minimalista, con acabados en piedra o en acero enriquecido por elementos en cerámica para emanar esencias aromáticas. Equipada con la tecnología de quemador motorizado PELLETPOWER® (versión Natural), intercambiador de calor THERMOCORE® y limpieza ordinaria y extraordinaria simplificadas EASY CLEANING.

Piano igienico in cristallo
Plateau hygiénique en cristal
Hygienic glass top

Schermo comandi programmabile
Panneau des commandes programmable
Programmable control screen

Maniglia diffondi aromi in preziosa ceramica
Poignée diffuseur en céramique précieuse
Precious ceramic handle with aroma diffusor

Porta focolare in vetro ceramico serigrafato e ghisa
Porte de foyer en fonte et cristal imprimé en sérigraphie
Screen-printed ceramic glass and cast iron firebox door

Maniglia removibile. Essenzialità nel design e maggior sicurezza
Poignée amovible. Design essentiel et sécurité accrue
Removable handle. Essentiality in design and greater safety. Simplified cleaning system

Piano salva cenere
Base ramasse-cendre
Protective ash pan

OPTIONAL:



iCONTROL
Sistema wi-fi iControl con web-App
Système wi-fi iControl avec web-App
Wi-fi system iControl with web-App
Wi-Fi System iControl mit web-App
Sistema wi-fi iControl con web-App



ROOM CONTROL
Termostato ambiente wireless con supporto a muro
Thermostat d'ambiance wireless avec support mural
Room wireless Thermostat with its wall support
Kabelloser Raumthermostat mit Wandhalterung
Termostato de habitación wireless con su soporte de pared

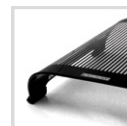

DINNER (a)
Coperchio scaldia vivande in cristallo
Couvercle chauffe-plat en cristal
Glass food-warming cover
Warmhalteplatte aus Kristallglas
Chapa para calentar comidas

(a) Solo per versione "Air - Plus" - Uniquement version "Air - Plus"
Only on "Air - Plus" version

Essenza Metalcolor



Bianco

Grigio

Bordeaux

Stone

Air/Plus 102
N.Air/N.Plus 12 102

Air 1127x518x596
Plus 1127x518x596
N.Air 12 1132x518x593
N.Plus 12 1132x518x593

Air/Plus 3,8 - 12,3
N.Air/N.Plus 12 3,2 - 12,2

Air/Plus 3,5 - 11,3
N.Air/N.Plus 12 3,1 - 11,3

Air/Plus 0,8 - 2,55
N.Air/N.Plus 12 0,65 - 2,6

Air 19
Plus 15
N.Air 12 20,7
N.Plus 12 17,2



(b) **Advanced cleaning**
PELLETPOWER®
bruciatore brevettato

Up to 500 hours NO-STOP

Eco DESIGN 2022

5 STELLE
DM 186/7

7 ÉTOILES

POLVERI (a)
7 mg/m³
13% di O₂

POLVERI (b)
9 mg/m³
13% di O₂

CSTB BlmSchV II
le futur en construction



(b)

(c) 16mx1 8mx2

(b)

(b)

(b) Solo per versione "Natural Air - Natural Plus" - Uniquement version "Natural Air - Natural Plus" - Only on "Natural Air - Natural Plus" version
(c) Solo per versione "Plus - Natural Plus" - Uniquement version "Plus - Natural Plus" - Only on "Plus - Natural Plus" version

La tipologia di fiamma ed il focolare possono variare a seconda delle versioni
Le type de flamme et le foyer peuvent varier selon les versions
Flame and the firebox can vary according to different model

A+ A++



14kW - 18kW - 21kW idra

ESSENZA idra metalcolor

- ITA Stufa a pellet dal design essenziale e minimalista, rivestita in pietra ollare oppure in acciaio colorato arricchita da una maiolica per diffondere essenze aromatiche. Dotata di bruciatore motorizzato con tecnologia PELLETPOWER® (modello Natural), scambiatore di calore THERMOCORE® e pulizia ordinaria e straordinaria semplificata EASY CLEANING.
- FRA Poêle à granulés au design essentiel et minimaliste, habillé en pierre ollaire ou en acier coloré, enrichi d'une céramique pour la diffusion d'essences aromatiques. Doté du brûleur motorisé avec technologie PELLETPOWER® (version Natural), de l'échangeur de chaleur THERMOCORE®, et du système de nettoyage ordinaire et extraordinaire simplifié EASY CLEANING.
- ENG Pellet stove with an essential and minimalist design, clad in soapstone or coloured steel embellished with aromatic essential oils. Equipped with the motorised fan technology PELLETPOWER® (Natural model) heat exchanger THERMOCORE® and simplified cleaning system EASY CLEANING.
- DEU Der Pelletofen mit geradlinigem und minimalistischem Design, verkleidet mit Sandstein oder farbigen Stahl und einer Duftschaale für aromatische Raumduftöle, wird Sie begeistern. Ausgestattet mit einem Raumluftventilator, mit der PELLETPOWER® Technologie (nur Natural), dem Wärmetauscher THERMOCORE® und dem einfachen EASY CLEANING Reinigungssystem.
- ESP Estufa de pellets de diseño esencial y minimalista, con acabados en piedra o en acero enriquecido por elementos en cerámica para emanar esencias aromáticas. Equipada con la tecnología de quemador motorizado PELLETPOWER® (versión Natural), intercambiador de calor THERMOCORE® y limpieza ordinaria y extraordinaria simplificadas EASY CLEANING.

Kit rivestimento a rapida installazione
Schnellmontage-Verkleidungsset
Quick installation coating kit
Kit habillage au montage rapide.
Kit de revestimiento de instalación rápida

product protected by design and innovation patent

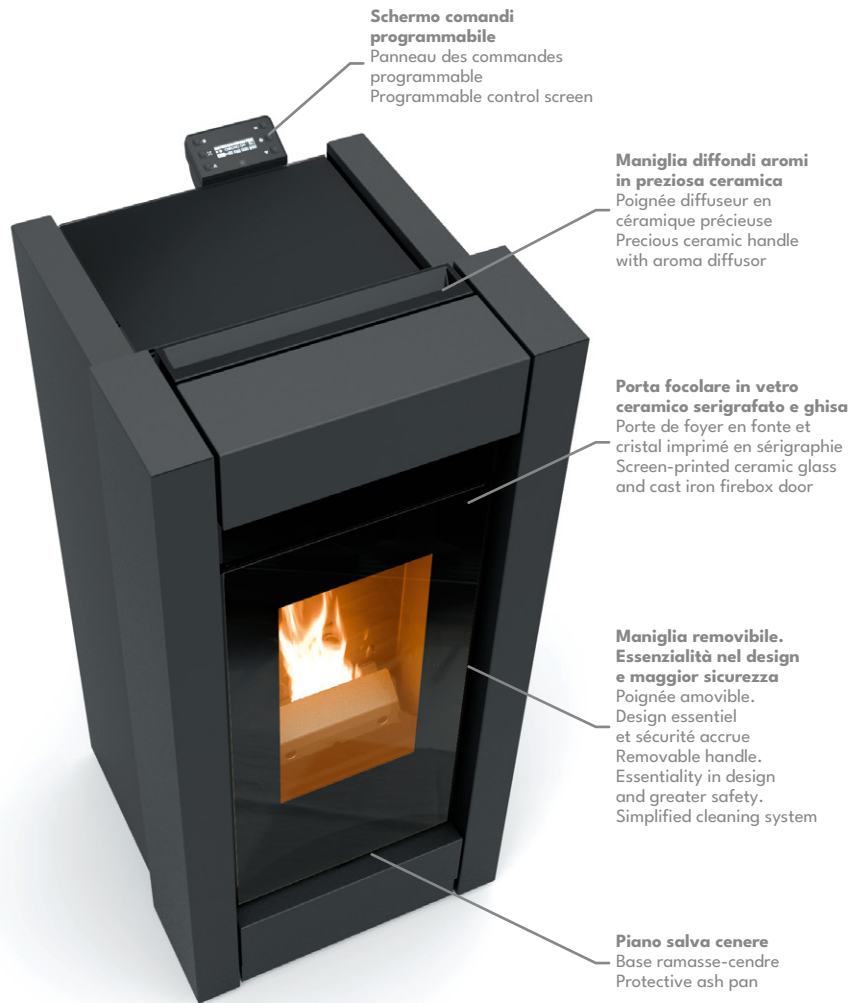

OPTIONAL:



INTEGRA TR-PACK
Thermocell® (250/400/500 lt)
Thermopuffer (400/500/1500 lt)
Thermosole® (2.0)



Thermofan:
Kit di ventilazione termostufa
Kit de ventilation thermo-poêle
Pellet thermo-stoves air convection kit
Raumlüftventilator für Pelletsöfenwassergeführt
Pellet thermo-stoves kit de convection de aire



Valvola termostatica a 3 vie 1" FFF 55 OT (optional)
Vanne thermostatique 3 voies 1" FFF 55 OT (optional)
Thermostatic valve 3 ways 1" FFF 55 OT (optional);

Sonda PT100 (optional-min 2 pz) per funzione «THERMOCONTROL»
Sonde PT100 (optional-min 2 pces) pour fonction «THERMOCONTROL»
PT100 sensor (optional-min 2 pc) for «THERMOCONTROL» function



iCONTROL
Sistema wi-fi iControl con web-App
Système wi-fi iControl avec web-App
Wi-fi system iControl with web-App
Wi-Fi System iControl mit web-App
Sistema wi-fi iControl con web-App



ROOM CONTROL
Termostato ambiente wireless con supporto a muro
Thermostat d'ambiance wireless avec support mural
Room wireless Thermostat with its wall support
Kabelloser Raumthermostat mit Wandhalterung
Termostato de habitación wireless con su soporte de pared

Bianco

Grigio

Bordeaux

Stone

Essenza Idra
Stone

Idra 14	118
Idra 18 Evo	160
Idra 21	191

1138x518x597

Idra 14	5,3 - 13,7
Idra 18 Evo	5,4 - 18,9
Idra 21	5,3 - 22,5

Idra 14	5,1 - 13,1
Idra 18 Evo	5,3 - 17,8
Idra 21	5,1 - 21,2

Idra 14	3,8 - 10,9
Idra 18 Evo	3,7 - 15,0
Idra 21	3,8 - 17,9

Idra 14	1,1 - 2,8
Idra 18 Evo	1,1 - 3,9
Idra 21	1,1 - 4,6



BimSch V II



La tipologia di fiamma ed il focolare possono variare a seconda delle versioni
Le type de flamme et le foyer peuvent varier selon les versions
Flame and the firebox can vary according to different model



A⁺ A⁺⁺
↑
G

	air plus
	12kW natural air
	12kW natural plus

SAINT MORITZ

Evo6

ITA Stile ed eleganza arricchita da preziose maiolica fatte a mano con pregiate lavorazioni in sottilievo. Dotata di bruciatore motorizzato con tecnologia PELLETPOWER® (modello Natural), scambiatore di calore THERMOCORE® e pulizia ordinaria e straordinaria semplificata EASY CLEANING.

FRA Style et élégance, enrichis de précieuses céramiques faites à la main, avec de remarquables détails en bas-relief. Doté du brûleur motorisé avec technologie PELLETPOWER® (version Natural), de l'échangeur de chaleur THERMOCORE®, et du système de nettoyage ordinaire et extraordinaire simplifié EASY CLEANING.

ENG Style and elegance enriched by precious majolica handmade with fine workmanship in relief. Equipped with the motorised fan technology PELLETPOWER® (Natural model) heat exchanger THERMOCORE® and simplified cleaning system EASY CLEANING.

DEU Stil und Eleganz angereichert mit wertvoller handgemachter Keramik mit feiner Verarbeitung und Reliefprägung. Ausgestattet mit einem Raumluftventilator, mit der PELLETPOWER® Technologie (nur Natural), dem Wärmetauscher THERMOCORE® und dem einfachen EASY CLEANING Reinigungssystem.

ESP Estilo y elegancia enriquecidos por preciosas cerámicas hechas a mano con acabados en bajo relieve. Equipada con la tecnología de quemador motorizado PELLETPOWER® (versión Natural), intercambiador de calor THERMOCORE® y limpieza ordinaria y extraordinaria simplificadas EASY CLEANING.

Top in cristallo con funzione Natural a qualsiasi potenza (b)

Top en cristal avec fonction Natural à tous les niveaux de puissance (b)
Crystal glass top with Natural function at any power (b)

Schermo comandi programmabile

Panneau des commandes programmable
Programmable control screen

Piano igienico, in cristallo

Chauffe-plats en cristal, hygiénique
Plate in hygienic glass

Preziosa maiolica artigianale fatta a mano

Précieuses céramiques artisanales faites à la main
Precious handmade majolica tiles

Porta focolare in vetro ceramico serigrafato e ghisa

Porte de foyer en fonte et cristal imprimé en sérigraphie
Screen-printed ceramic glass and cast iron firebox door

OPTIONAL:



iCONTROL

Sistema wi-fi iControl con web-App
Système wi-fi iControl avec web-App
Wi-Fi system iControl with web-App
Wi-Fi System iControl mit web-App
Sistema wi-fi iControl con web-App



ROOM CONTROL

Termostato ambiente wireless con supporto a muro
Thermostat d'ambiance wireless avec support mural
Room wireless Thermostat with its wall support
Kabelloser Raumthermostat mit Wandhalterung
Termostato de habitación wireless con su soporte de pared



DINNER (a)

Coperchio scaldia vivande in cristallo
Couvercle chauffe-plat en cristal
Glass food-warming cover
Warmhalteplatte aus Kristallglas
Chapa para calentar comidas

(a) Solo per versione "Air - Plus" - Uniquement version "Air - Plus"
Only on "Air - Plus" version

Bianco



Beige



Tortora



Bordeaux



Bianco



Tortora

Air/Plus 102
N.Air/N.Plus 12 102



Air 1132x660x641
Plus 1132x660x641
N.Air 12 1115x660x640
N.Plus 12 1115x660x640



Air/Plus 3,8 - 12,3
N.Air/N.Plus 12 3,2 - 12,2



Air/Plus 3,5 - 11,3
N.Air/N.Plus 12 3,1 - 11,3



Air/Plus 0,8 - 2,55
N.Air/N.Plus 12 0,65 - 2,6



Air 19
Plus 15
N.Air 12 20,7
N.Plus 12 17,2



(b) **Advanced cleaning**
PELLETPOWER®
bruciatore brevettato

Up to 500 hours NO-STOP

Eco DESIGN 2022

5 STELLE
DM 186/7

7 ÉTOILES

POLVERI (a)
7 mg/m³
13% di O₂

POLVERI (b)
9 mg/m³
13% di O₂

CSTB BlmSchV II
le futur en construction



(b)

(c) 16mx1 8mx2

(b)

(b)

(b)

(b) Solo per versione "Natural Air - Natural Plus" - Uniquement version "Natural Air - Natural Plus" - Only on "Natural Air - Natural Plus" version
(c) Solo per versione "Plus - Natural Plus" - Uniquement version "Plus - Natural Plus" - Only on "Plus - Natural Plus" version

La tipologia di fiamma ed il focolare possono variare a seconda delle versioni
Le type de flamme et le foyer peuvent varier selon les versions
Flame and the firebox can vary according to different model



14kW - 18kW - 21kW idra



SAINT MORITZ idra

ITA Stile ed eleganza arricchita da preziose maiolica fatte a mano con pregiate lavorazioni in sottorilievo. Dotata di bruciatore motorizzato con tecnologia PELLETPOWER®, scambiatore di calore THERMOCORE® e pulizia ordinaria e straordinaria semplificata EASY CLEANING.

FRA

Style et élégance, enrichis de précieuses céramiques faites à la main, avec de remarquables détails en bas-relief. Doté du brûleur motorisé avec technologie PELLETPOWER®, de l'échangeur de chaleur THERMOCORE®, et du système de nettoyage ordinaire et extraordinaire simplifié EASY CLEANING.

ENG

Style and elegance enriched by precious majolica handmade with fine workmanship in relief. Equipped with the motorised fan technology PELLETPOWER® heat exchanger THERMOCORE® and simplified cleaning system EASY CLEANING.

DEU

Stil und Eleganz angereichert mit wertvoller handgemachter Keramik mit feiner Verarbeitung und Reliefprägung. Ausgestattet mit einem Raumlüftventilator, mit der PELLETPOWER® Technologie, dem Wärmetauscher THERMOCORE® und dem einfachen EASY CLEANING Reinigungssystem.

ESP

Estilo y elegancia enriquecidos por preciosas cerámicas hechas a mano con acabados en bajo relieve. Equipada con la tecnología de quemador motorizado PELLETPOWER®, intercambiador de calor THERMOCORE® y limpieza ordinaria y extraordinaria simplificadas EASY CLEANING.

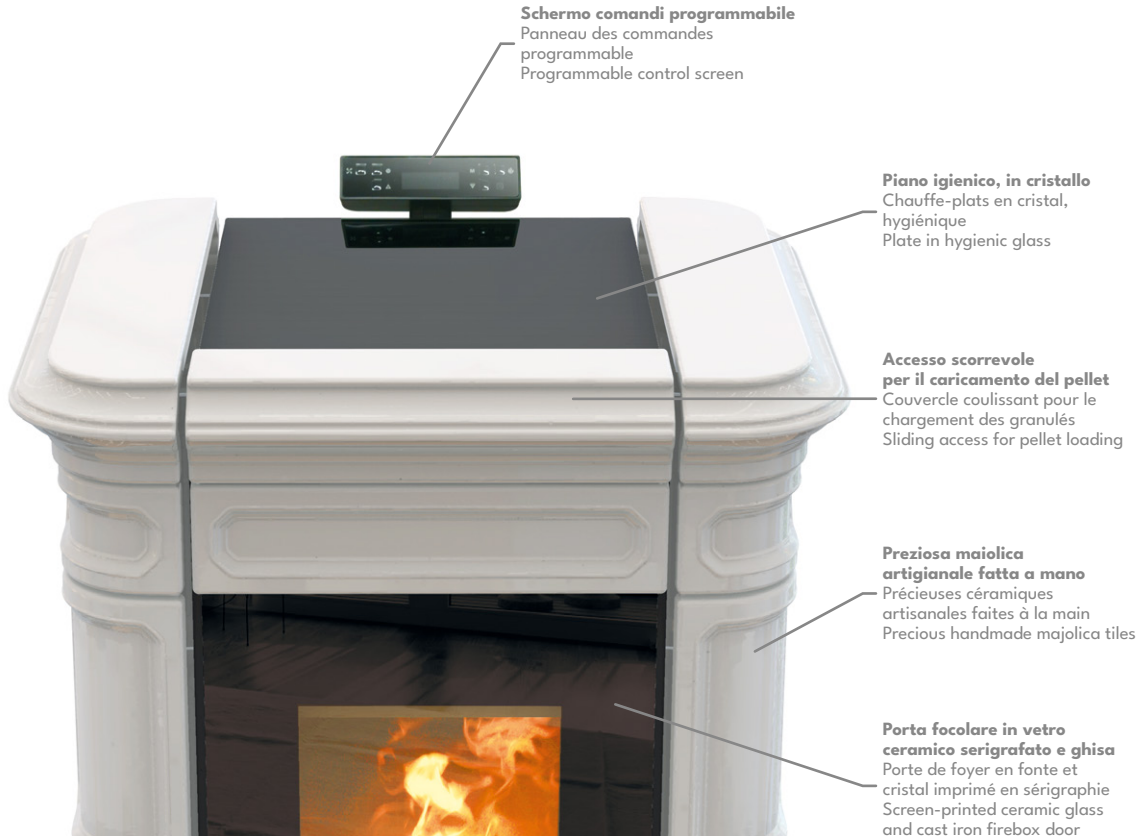

Schermo comandi programmabile
Panneau des commandes programmable
Programmable control screen

Piano igienico, in cristallo
Chauffe-plats en cristal, hygiénique
Plate in hygienic glass

Accesso scorrevole per il caricamento del pellet
Couvercle coulissant pour le chargement des granulés
Sliding access for pellet loading

Preziosa maiolica artigianale fatta a mano
Précieuses céramiques artisanales faites à la main
Precious handmade majolica tiles

Porta focolare in vetro ceramico serigrafato e ghisa
Porte de foyer en fonte et cristal imprimé en sérigraphie
Screen-printed ceramic glass and cast iron firebox door

OPTIONAL:



INTEGRA TR-PACK
Thermocell® (250/400/500 lt)
Thermopuffer (400/500/1500 lt)
Thermosole® (2.0)



Thermofan:
Kit di ventilazione termostufa
Kit de ventilation thermo-poêle
Pellet thermo-stoves air convection kit
Raumlüftventilator für Pelletsöfenwassergeführt
Pellet thermo-stoves kit de convection de aire



Valvola termostatica a 3 vie 1" FFF 55 OT (optional)
Vanne thermostatique 3 voies 1" FFF 55 OT (optional)
Thermostatic valve 3 ways 1" FFF 55 OT (optional)

Sonda PT100 (optional-min 2 pz) per funzione «THERMOCONTROL»
Sonde PT100 (optional-min 2 pces) pour fonction «THERMOCONTROL»
PT100 sensor (optional-min 2 pc) for «THERMOCONTROL» function



iCONTROL
Sistema wi-fi iControl con web-App
Système wi-fi iControl avec web-App
Wi-fi system iControl with web-App
Wi-Fi System iControl mit web-App
Sistema wi-fi iControl con web-App



ROOM CONTROL
Termostato ambiente wireless con supporto a muro
Thermostat d'ambiance wireless avec support mural
Room wireless Thermostat with its wall support
Kabelloser Raumthermostat mit Wandhalterung
Termostato de habitación wireless con su soporte de pared

Bianco



Beige



Tortora



Bordeaux



Bianco
Tortora



Idra 14	118
Idra 18 Evo	160
Idra 21	191



1121x660x644



Idra 14	5,3 - 13,7
Idra 18 Evo	5,4 - 18,9
Idra 21	5,3 - 22,5



Idra 14	5,1 - 13,1
Idra 18 Evo	5,3 - 17,8
Idra 21	5,1 - 21,2



Idra 14	3,8 - 10,9
Idra 18 Evo	3,7 - 15,0
Idra 21	3,8 - 17,9



Idra 14	1,1 - 2,8
Idra 18 Evo	1,1 - 3,9
Idra 21	1,1 - 4,6



Advanced cleaning
PELLETPOWER®
bruciatore brevettato

Up to 500 hours NO-STOP

Eco DESIGN 2022

5 STELLE DM 186/7

7 ÉTOILES

BimSchV II

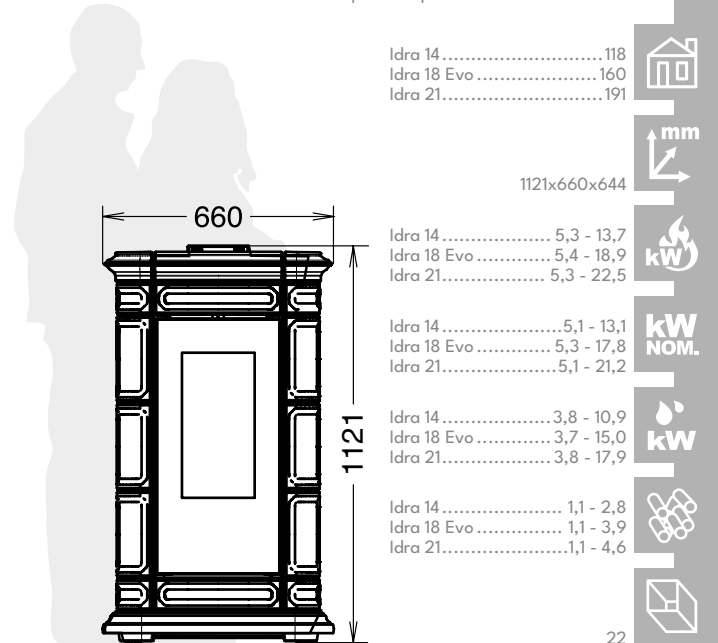

La tipologia di fiamma ed il focolare possono variare a seconda delle versioni
Le type de flamme et le foyer peuvent varier selon les versions
Flame and the firebox can vary according to different model



12kW natural air

12kW natural plus

SAINT MORITZ

supreme Evo6



ITA Raffinata eleganza in stile romantico per tutti coloro che amano circondarsi da preziosi complementi d'arredo, Saint Moritz Supreme rappresenta la massima espressione di cura del dettaglio, dalle preziose maioliche lavorate a mano al pratico vano scaldavivande. Ideale per chi vuole distribuire il calore in ambienti diversi e riscaldare più locali, basta un semplice gesto per gestire il flusso dell'aria verso le canalizzazioni. Due canalizzazioni, indipendenti l'una dall'altra con la possibilità di gestire entrambi i flussi separatamente con la massima flessibilità. Pulizia straordinaria e ordinaria semplificata con tecnologia EASY CLEANING.

FRA Élégance raffinée en style romantique, pour qui aime s'entourer d'objets précieux. Saint Moritz Supreme représente la plus grande expression dans le soin du détail. Doté d'un chauffe-plats, pratique, hygiénique et simple à nettoyer. Idéal pour qui désire distribuer l'air chaud dans des pièces différentes et réchauffer divers locaux. Un simple geste suffit pour adresser le flux de l'air vers les canalisations. Deux canalisations indépendantes, pour avoir la possibilité de gérer les flux indépendamment et avec la plus grande flexibilité. Doté du système de nettoyage ordinaire et extraordinaire simplifié EASY CLEANING.

ENG Refined elegance in a romantic style, for all those who love to surround themselves with precious furnishings. Saint Moritz Supreme is the ultimate expression of attention to detail, from precious handmade majolica to the practical food warmer. If you would like a ducted hot air supply into several rooms, Saint Moritz Supreme provides an ideal solution. It is possible to warm different spaces quickly and easily via an intuitive control system designed to distribute hot air into the ducting system. The twin air ducting system is designed to provide independent outlets which are both able to share air the flow with maximum flexibility. Equipped with simplified cleaning system EASY CLEANING.

DEU Raffinierte Eleganz gepaart mit romantischem Stil, so präsentiert sich dieser Pelletofen all jenen, die sich gerne mit edlen Objekten umgeben. Saint Moritz Supreme ist der ultimative Ausdruck von Aufmerksamkeit bis ins kleinste Detail. Der Ofen ist mit einer hygienischen Warmhaltefläche, einfach zu reinigen ausgestattet. Ideal für diejenigen, die die Wärme in verschiedenen Umgebungen verteilt möchten, um sie zu heizen, nur eine einfache Geste, um das Strömen von Luft in den Kanalisierungen zu verwalten. Zwei Kanalisierungen, unabhängig voneinander, mit der Möglichkeit, die Ströme in unabhängiger Weise zu verwalten und mit der maximalen Flexibilität. Ordentliche und außerordentliche Reinigung leichter mit EASY CLEANING System.

ESP Elegancia refinada en un estilo romantico, para todos los que aman rodearse con muebles preciosos, Saint Moritz Supreme es la máxima expresión de la atención al detalle, desde le preciose majolica hasta el práctico hueco para calentar comidas. Ideal para quien quiere distribuir el calor en varias habitaciones; de manera muy sencilla permite gestionar el flujo de aire a través de la canalización. Dos canalizaciones, independientes la una de la otra con posibilidad de gestionar los flujos de aire con la máxima flexibilidad. Limpiezas ordinarias y extraordinarias simplificadas EASY CLEANING.

**Uscite per canalizzazione disponibili:
due posteriori (a)**
Sorties de canalisation disponibles :
2 arrières (a)
Available ducting outlets: two rear (a)

**Accesso per il
caricamento del pellet**
Couvercle pour le
chargement des granulés
Access for pellet loading

Schermo comandi programmabile
Panneau des commandes
programmable
Programmable control screen

**Top in cristallo con funzione
Natural a qualsiasi potenza**
Top en cristal avec fonction Natural
à tous les niveaux de puissance
Crystal glass top with
Natural function at any power

**Preziosa maiolica
artigianale fatta a mano**
Précieuses céramiques
artisanales faites à la main
Precious handmade majolica tiles

**Vano scaldavivande
con piano in ceramica**
Compartment chauffe-plats
avec plateau en céramique
Food warming compartment
with majolica top

**Porta focolare in vetro
ceramico serigrafato e ghisa**
Porte de foyer en fonte et
cristal imprimé en sérigraphie
Screen-printed ceramic glass
and cast iron firebox door

OPTIONAL:



iCONTROL
Sistema wi-fi iControl con web-App
Système wi-fi iControl avec web-App
Wi-fi system iControl with web-App
Wi-Fi System iControl mit web-App
Sistema wi-fi iControl con web-App



ROOM CONTROL
Termostato ambiente wireless con supporto a muro
Thermostat d'ambiance wireless avec support mural
Room wireless Thermostat with its wall support
Kabelloser Raumthermostat mit Wandhalterung
Termostato de habitación wireless con su soporte de pared

Bianco



Beige



Tortora



Bordeaux



102	
1319x660x637	
3,2 - 12,2	
3,1 - 11,3	
0,65 - 2,6	
N.Air 29,5	
N.Plus 26	



Advanced cleaning
PELLETPOWER®
bruciatore brevettato

Up to
500 hours
NO-STOP

Eco
DESIGN
2022

5
STELLE
DM 186/7

7
ÉTOILES

POLVERI
9
mg/m³
13% di O₂

CSTB **BImSchV II**
le futur en construction



(a) 16mx1
8mx2

La tipologia di fiamma ed il focolare possono variare a seconda delle versioni
Le type de flamme et le foyer peuvent varier selon les versions
Flame and the firebox can vary according to different model

(a) Solo per versione "Natural Plus" - Uniquement version "Natural Plus" - Only on "Natural Plus" version



supreme - 29kW idra

SAINT MORITZ

supreme idra

idra 29 Evo



ITA Raffinata eleganza in stile romantico per tutti coloro che amano circondarsi da preziosi complementi d'arredo, Saint Moritz® Supreme diventa da oggi disponibile nella versione Idra. Questa termostufa rappresenta la massima espressione di cura del dettaglio, dalle preziose maioliche lavorate a mano all'innovativo bruciatore motorizzato con tecnologia PELLETPOWER®. Grazie all'efficiente scambiatore di calore THERMOCORE®, formato da un fascio tubiero dotato di turbolatori e grazie al funzionamento automatico con modulazione di potenza, Saint Moritz® idra Supreme ottiene un rendimento superiore al 90%. La robustezza del corpo caldaia, la silenziosità, la facilità di gestione, la pulizia semplificata e le basse emissioni fanno della gamma Idra una soluzione alternativa ed ecologica al tradizionale sistema di riscaldamento domestico.

FRA Élégance raffinée en style romantique pour qui aime s'entourer de meubles précieux. Le Saint Moritz® Supreme est aujourd'hui disponible dans la version Idra. Ce thermo-poêle représente la plus grande expression de l'attention au détail, des précieuses céramiques faites à la main à l'innovant brûleur motorisé avec technologie brevetée PELLETPOWER®. Grâce à son efficient échangeur de chaleur THERMOCORE® formé d'un faisceau tubulaire doté de turbulateurs, et grâce à son fonctionnement automatique avec modulation de puissance, le Saint Moritz® Idra Supreme obtient un rendement supérieur à 90%. La robustesse du corps de chaudière, le silence de fonctionnement, la facilité de gestion, le nettoyage simplifié, et les basses émissions, font de la gamme Idra une solution alternative et écologique au système de chauffage domestique traditionnel.

ENG Refined elegance in romantic style, for all those who love to surround themselves with precious furnishings. Saint Moritz Supreme is now available also in the idra version. This heating generator represents the maximum expression of attention to detail, from the precious majolica handmade by master craftsmen to the PELLETPOWER® innovative patented burner. Thanks to the high efficient vertical pipes heat exchanger THERMOCORE®, that increases the exchange surface, Saint Moritz® Idra Supreme performs an efficiency of more than 90%. The stability of the structure of the boiler, the silence, the easier way to maintain and clean it and its very low emissions make the idra collection the alternative and ecological solution to conventional heating systems.

DEU Raffinierte Eleganz gepaart mit romantischem Stil, so präsentiert sich dieser Pelletofen all jenen, die sich gerne mit edlen Objekten umgeben. St. Moritz Supreme ist jetzt auch in wassergeführter Version erhältlich. Dieser Wärmeerzeuger stellt den maximalen Ausdruck der Liebe zum Detail dar. Von der kostbaren handgefertigten Majolika bis zum innovativen PELLETPOWER® patentierten Brenner. Dank des hocheffizienten THERMOCORE® Rohrwärmetauschers, erhöht sich die Wärmetauscher Fläche und führt zu einem Wirkungsgrad von mehr als 90%. Die stabile Struktur des Kessels, der ruhige Betrieb und die einfache Art und Weise das Produkt zu reinigen gepaart mit den niedrigen Emissionen machen den Ofen zu einer ökologischen und praktikablen Alternative zu konventionellen Heizsystemen.

ESP Refinada elegancia en un estilo romántico, dedicada a los que les gusta rodearse de elementos de decoración, San Moritz® Supreme ahora está disponible en versión Hydra. Este generador representa la máxima expresión de la atención al detalle, desde la preciosa mayólica hecha a mano hasta el quemador motorizado patentado con la tecnología PELLETPOWER®. Gracias al eficiente intercambiador de calor THERMOCORE®, formado a partir de un haz de tubos equipados con turbuladores, y gracias a la operación en automático con modulación de potencia, San Moritz® hydra Supreme consigue un rendimiento superior al 90%. La robustez del cuerpo de la caldera, el poco ruido, la facilidad de gestión, la limpieza simplificada y las bajas emisiones destacan la gama Hydra como primera solución alternativa y ecológica al sistema de calefacción tradicional de cada vivienda.



OPTIONAL:



INTEGRA TR-PACK
Thermocell® (250/400/500 lt)
Thermopuffer (400/500/1500 lt)
Thermosole® (2.0)



Thermofan:
Kit di ventilazione termostufa
Kit de ventilation thermo-poêle
Pellet thermo-stoves air convection kit
Raumluftventilator für Pelletsofenwassergeführt
Pellet thermo-stoves kit de convection de aire



Valvola termostatica a 3 vie 1" FFF 55 OT (optional)
Vanne thermostatique 3 voies 1" FFF 55 OT (optional)
Thermostatic valve 3 ways 1" FFF 55 OT (optional)

Sonda PT100 (optional-min 2 pz) per funzione «THERMOCONTROL»
Sonde PT100 (optional-min 2 pces) pour fonction «THERMOCONTROL»
PT100 sensor (optional-min 2 pc) for «THERMOCONTROL» function



iCONTROL
Sistema wi-fi iControl con web-App
Système wi-fi iControl avec web-App
Wi-fi system iControl with web-App
Wi-Fi System iControl mit web-App
Sistema wi-fi iControl con web-App



ROOM CONTROL
Termostato ambiente wireless con supporto a muro
Thermostat d'ambiance wireless avec support mural
Room wireless Thermostat with its wall support
Kabelloser Raumthermostat mit Wandhalterung
Termostato de habitación wireless con su soporte de pared

Bianco



Beige



Tortora



Bordeaux



Idra Supreme.....	203
Idra29Evo	213

1321x660x640

Idra Supreme.....	6,8 - 23,7
Idra29Evo	9,1 - 25,4

Idra Supreme.....	6,5 - 22,5
Idra29Evo	8,6 - 23,7

Idra Supreme.....	5,0 - 19,6
Idra29Evo	7,3 - 20,6

Idra Supreme.....	1,4 - 4,9
Idra29Evo	1,9 - 5,25

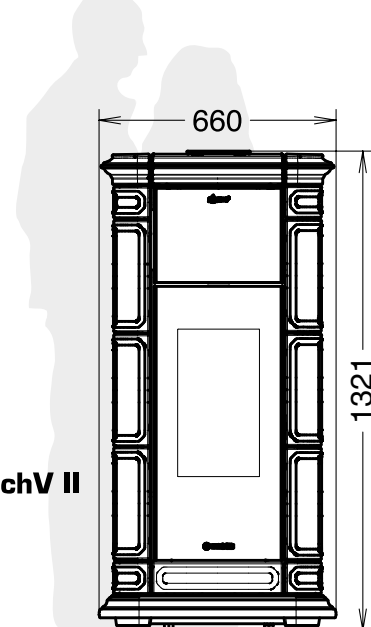

BlmSchV II



(a) Solo per versione "Idra29Evo" - Uniquement version "Idra29Evo" - Only on "Idra29Evo" version



A+ A++
↑ G



air
plus

14kW - 18kW - 21kW idra

LIENZ Evo6

ITA Il fascino intramontabile di una stufa rivestita in pregiata maiolica lavorata a mano da maestri artigiani, di serie un pratico vano scaldavivande a scomparsa in cristallo e maiolica. Dotata di bruciatore motorizzato con tecnologia PELLETPOWER®, scambiatore di calore THERMOCORE® e pulizia ordinaria e straordinaria semplificata EASY CLEANING.

FRA Le charme indémodable d'un poêle revêtu de précieuses céramiques faites à la main par des maîtres-artisans, surmonté d'un tiroir-chauffe-plats pratique, en cristal et céramique. Doté du brûleur motorisé avec technologie PELLETPOWER®, de l'échangeur de chaleur THERMOCORE®, et du système de nettoyage ordinaire et extraordinaire simplifié EASY CLEANING.

ENG The timeless appeal of a stove covered with fine majolica hand-made by master craftsmen, a practical hot plate covered by retractable glass and earthenware. Equipped with the motorised fan technology PELLETPOWER® heat exchanger THERMOCORE® and simplified cleaning system EASY CLEANING.

DEU Die zeitlose Erscheinung eines Ofens mit einer Verkleidung aus feiner Keramik, hergestellt aus Meisterhand, kombiniert mit einem ausziehbaren Warmhaltefach, gibt einen ganz besonderen Charme. Ausgestattet mit einem Raumluftventilator, mit der PELLETPOWER® Technologie, dem Wärmetauscher THERMOCORE® und dem einfachen EASY CLEANING Reinigungssystem.

ESP El eterno atractivo de una estufa revestida con fina mayólica hecha a mano por maestros artesanos, ofrece un práctico hueco retráctil para calentar comidas en cristal y cerámica. Equipada con la tecnología de quemador motorizado PELLETPOWER®, intercambiador de calor THERMOCORE® y limpieza ordinaria y extraordinaria simplificadas EASY CLEANING.

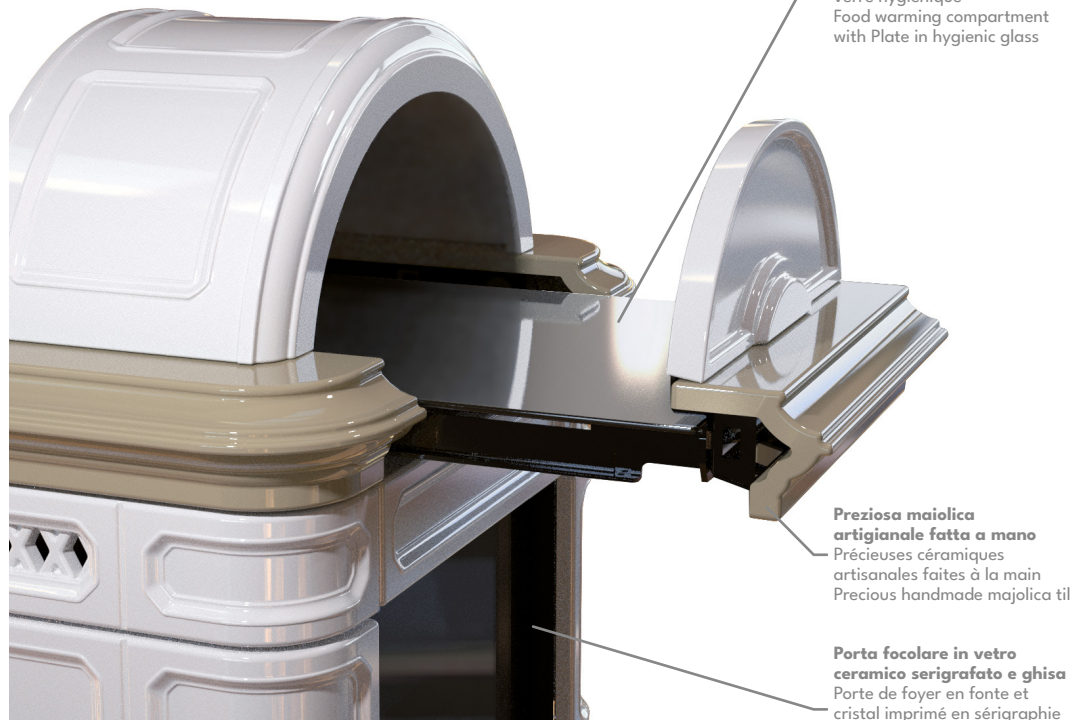

Vano scaldavivande con piano igienico in cristallo
 Chauffe-plats avec plateau en verre hygiénique
 Food warming compartment with Plate in hygienic glass

Preziosa maiolica artigianale fatta a mano
 Précieuses céramiques artisanales faites à la main
 Precious handmade majolica tiles

Porta focolare in vetro ceramico serigrafato e ghisa
 Porte de foyer en fonte et cristal imprimé en sérigraphie
 Screen-printed ceramic glass and cast iron firebox door

OPTIONAL:



iCONTROL
Sistema wi-fi iControl con web-App
 Système wi-fi iControl avec web-App
 Wi-fi system iControl with web-App
 Wi-Fi System iControl mit web-App
 Sistema wi-fi iControl con web-App



ROOM CONTROL
Termostato ambiente wireless con supporto a muro
 Thermostat d'ambiance wireless avec support mural
 Room wireless Thermostat with its wall support
 Kabelloser Raumthermostat mit Wandhalterung
 Termostato de habitación wireless con su soporte de pared



INTEGRA TR-PACK
 Thermocell® (250/400/500 lt)
 Thermopuffer (400/500/1500 lt)
 Thermosole® (2.0)



Thermofan:
Kit di ventilazione termostufa
 Kit de ventilation thermo-poêle
 Pellet thermo-stoves air convection kit
 Raumluftventilator für Pelletsöfenwassergeführt
 Pellet thermo-stoves kit de convección de aire



Valvola termostatica a 3 vie 1" FFF 55 OT (optional)
 Vanne thermostatique 3 voies 1" FFF 55 OT (optional)
 Thermostatic valve 3 ways 1" FFF 55 OT (optional)



Sonda PT100 (optional-min 2 pz) per funzione «THERMOCONTROL»
 Sonde PT100 (optional-min 2 pces) pour fonction «THERMOCONTROL»
 PT100 sensor (optional-min 2 pc) for «THERMOCONTROL» function

(c)

Bianco



Beige



Tortora



Bordeaux



Bianco

Tortora

Air/Plus	102
Idra 14	118
Idra 18 Evo	160
Idra 21	191

1323x660x644

Air/Plus	3,8 - 12,3
Idra 14	5,3 - 13,7
Idra 18 Evo	5,4 - 18,9
Idra 21	5,3 - 22,5

Air/Plus	3,5 - 11,3
Idra 14	5,1 - 13,1
Idra 18 Evo	5,3 - 17,9
Idra 21	5,1 - 21,2

Idra 14	3,8 - 10,9
Idra 18 Evo	3,7 - 15,0
Idra 21	3,8 - 17,9

Air/Plus	0,8 - 2,6
Idra 14	1,1 - 2,8
Idra 18 Evo	1,1 - 3,9
Idra 21	1,1 - 4,6

Air	19
Plus	15
Idra 14/18 Evo/21	22

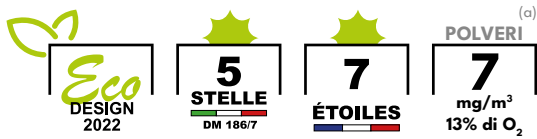
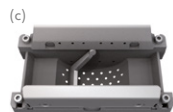
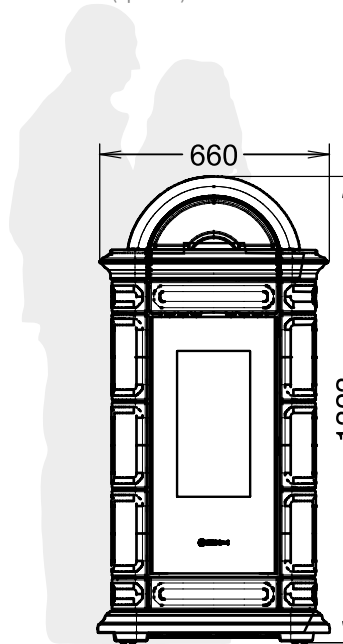

CSTB BImSchV II
 le futur en construction



(a) (a) (a) (b) 16mx1 8mx2

(a) Solo per versione "Air - Plus" - Uniquement version "Air - Plus" - Only on "Air - Plus" version
 (b) Solo per versione "Plus" - Uniquement version "Plus" - Only on "Plus" version
 (c) Solo per versione "Idra 14/18 Evo/21" - Uniquement version "Idra 14/18 Evo/21" - Only on "Idra 14/18 Evo/21" version

La tipologia di fiamma ed il focolare possono variare a seconda delle versioni
 Le type de flamme et le foyer peuvent varier selon les versions
 Flame and the firebox can vary according to different model



plus

ESPRIT 490 Evo6

ITA Grazie all'altezza contenuta è l'inserto perfetto per chi vuole recuperare un focolare esistente. Ventilato e canalizzabile con flusso d'aria orientabile, dotato di bruciatore autopulente fino a 500 ore NO-STOP, vetro serigrafato, camera di combustione e porta focolare in ghisa, scambiatore di calore a fascio tubiero, facilità di pulizia ordinaria e straordinaria, predisposizione wi-fi technology.

FRA Grâce à sa hauteur contenue, c'est l'insert parfait pour qui veut récupérer un foyer existant. Ventilé et canalisable avec flux d'air orientable, doté de brûleur autonettoyant jusqu'à 500 heures NO-STOP, vitre sérigraphiée, chambre de combustion et porte du foyer en fonte, échangeur de chaleur à faisceau tubulaire, nettoyages ordinaire et extraordinaire faciles, prédisposition à la technologie Wi-Fi.

ENG The insert's compact height makes it the perfect solution for those who want to bring an existing fireplace back to life. Ventilated and ductable with air flow that can be directed as desired, fitted with a self-cleaning burner with up to 500 hours NO-STOP operation, silk-screened glass, cast iron combustion chamber and firebox door, tube heat exchanger, easy routine and extraordinary cleaning, provision for Wi-Fi technology.

DEU Dank seiner geringen Höhe ist der Pelletheizeinsatz ideal für denjenigen, der eine bestehende Feuerstelle nutzen möchte. Belüftet und kanalisierbar mit orientierbarem Luftstrom, selbstreinigender Brenner für bis zu 500 Stunden NON-STOP, Glas mit Siebdruck, Brennkammer und Brennraumtür aus Gusseisen, Rohrbündelwärmetauscher, leichte ordentliche und außerordentliche Reinigung, Wi-Fi-Anschluss möglich.

ESP Gracias a su altura reducida, es el insertable para chimenea ideal para quienes desean reutilizar un hogar preexistente. Ventilado y canalizable con flujo de aire orientable, dotado de quemador autolimpiante capaz de funcionar hasta 500 horas NO-STOP, vidrio serigrafado, cámara de combustión y puerta del hogar de hierro fundido, intercambiador de calor tubular, facilidad de limpieza ordinaria y extraordinaria, predisposición para tecnología wifi.

Una canalizzazione superiore
 Une canalisation supérieure
 One upper ducting outlet

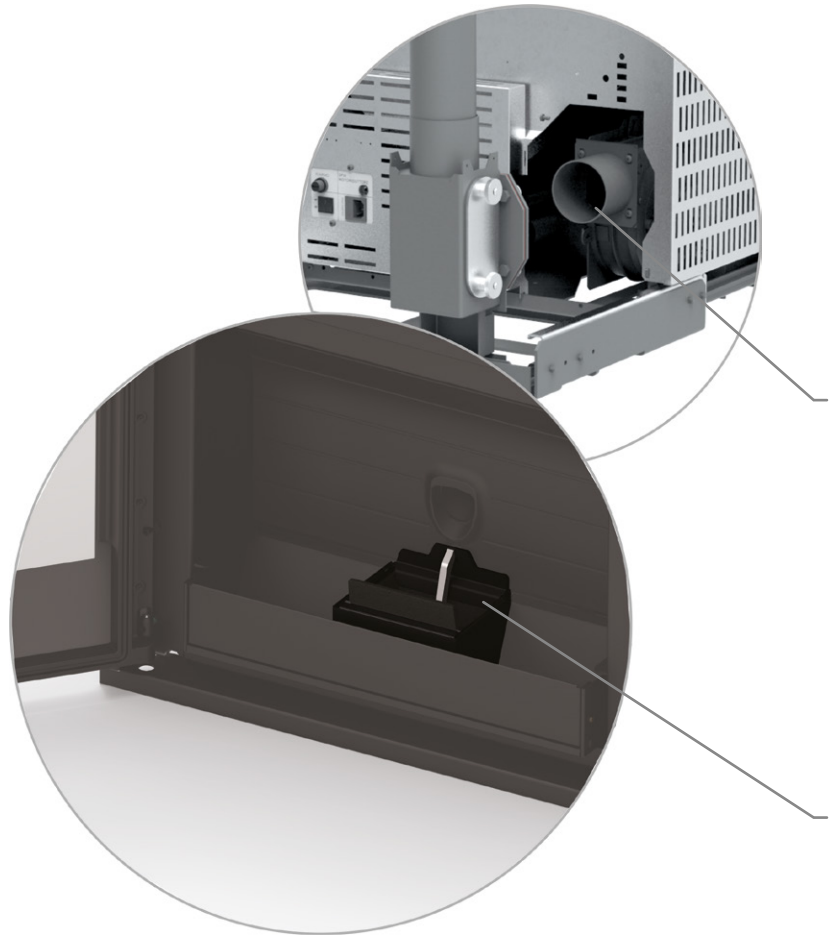

- Scarico fumi con innesto a baionetta con dispositivo di sicurezza meccanico ed elettrico per sbloccare l'inserto ed effettuare il carico di pellet.
- Sortie des fumées à branchement rapide avec dispositif de sécurité mécanique et électrique pour le déblocage de l'insert et le chargement des granulés.
- Smoke outlet with bayonet fitting and mechanical and electrical safety device to unlock the insert and load the pellets.

Bruciatore autopulente brevettato Pelletpower®
 Brûleur autonettoyant breveté Pelletpower®
 Pelletpower® patented self-cleaning burner

OPTIONAL:



iCONTROL
 Sistema wi-fi iControl con web-App
 Système wi-fi iControl avec web-App
 Wi-fi system iControl with web-App
 Wi-Fi System iControl mit web-App
 Sistema wi-fi iControl con web-App



ROOM CONTROL
 Termostato ambiente wireless con supporto a muro
 Thermostat d'ambiance wireless avec support mural
 Room wireless Thermostat with its wall support
 Kabelloser Raumthermostat mit Wandhalterung
 Termostato de habitación wireless con su soporte de pared



Kit botola Esprit
 Kit de chargement pour Esprit
 Charging kit for Esprit
 Bausatz Einfüllschacht für Esprit
 Kit de carga de pellet para Esprit



Piedistallo regolabile in altezza
 Socle réglable en hauteur
 Height-adjustable pedestal
 Höhenverstellbarer Sockel
 Soporte ajustable en altura

Nero



90



490x667x459



2,8 - 11



2,6 - 10



0,57 - 2,28



12,5



Advanced cleaning
PELLETPOWER®
 bruciatore brevettato

Up to
500 hours
 NO-STOP

Eco
 DESIGN
 2022

5
 STELLE
 DM 186/7

7
 ÉTOILES

POLVERI
7
 mg/m³
 13% di O₂

BlmSchV II



12mx1
 6mx2

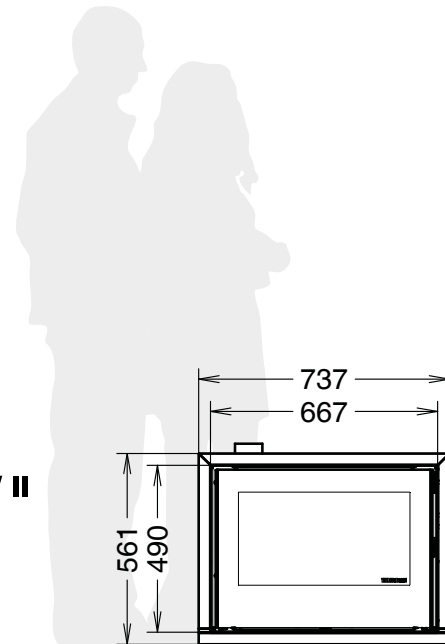

A+ A++



plus

ESPRIT 540 Evo6

- ITA** Inserto a pellet ventilato e canalizzabile con flusso d'aria orientabile, dotato di bruciatore autopulente fino a 500 ore NO-STOP. Cassetto di caricamento pellet in cristallo a scomparsa, vetro serigrafato, camera di combustione e porta focolare in ghisa, scambiatore di calore a fascio tubiero, facilità di pulizia ordinaria e straordinaria, predisposizione wi-fi technology.
- FRA** Insert à granulés ventilé et canalisable avec flux d'air orientable, doté de brûleur autonettoyant breveté jusqu'à 500 heures NO-STOP. Tiroir de chargement des granulés en cristal rétractable, vitre sérigraphiée, chambre de combustion et porte du foyer en fonte, échangeur de chaleur à faisceau tubulaire, nettoyages ordinaire et extraordinaire faciles, prédisposition à la technologie Wi-Fi.
- ENG** Pellet insert, ventilated and ductable with air flow that can be directed as desired, fitted with a self-cleaning burner with up to 500 hours NO-STOP operation. Concealed crystal glass pellet loading drawer, silk-screened glass, cast iron combustion chamber and firebox door, tube heat exchanger, easy routine and extraordinary cleaning, provision for Wi-Fi technology.
- DEU** Belüfteter und kanalisierbarer Pelletheizeinsatz mit orientierbarem Luftstrom, selbstreinigender Brenner für bis zu 500 Stunden NO-STOP. Einfahrbarer Kristallglaskasten für die Pelletaufgabe, Glas mit Siebdruck, Brennkammer und Brennraumtür aus Gusseisen, Rohrbündelwärmetauscher, leichte ordentliche und außerordentliche Reinigung, für Wi-Fi-Anschluss geeignet.
- ESP** Insertable para chimenea de pellets ventilado y canalizable con flujo de aire orientable, dotado de quemador autolimpiante capaz de funcionar hasta 500 horas NO-STOP. Cajón de carga de pellets retráctil de cristal, vidrio serigrafiado, cámara de combustión y puerta del hogar de hierro fundido, intercambiador de calor tubular, facilidad de limpieza ordinaria y extraordinaria, predisposición para tecnología wifi.

Una canalizzazione superiore
 Une canalisation supérieure
 One upper ducting outlet

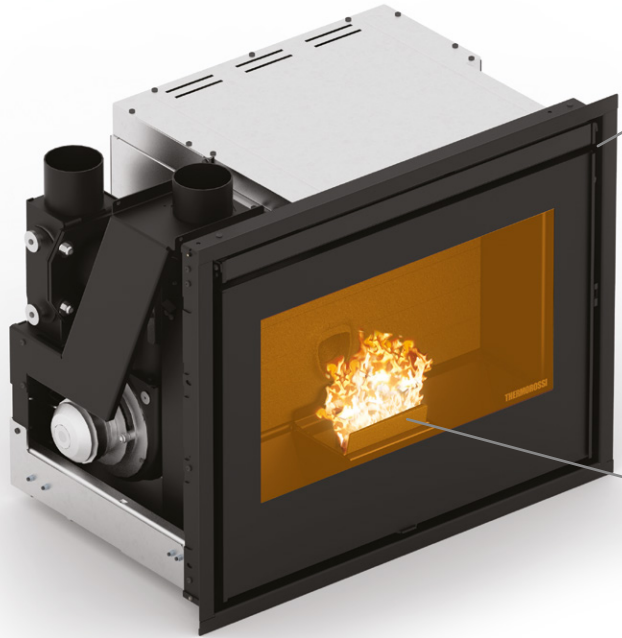

Comando per orientare il flusso d'aria dal frontale alla canalizzazione
 Commande pour orienter le flux d'air de la partie frontale à la canalisation
 Control for directing the air flow from the front to the ducting outlet

Bruciatore autopulente brevettato Pelletpower®
 Brûleur autonettoyant breveté Pelletpower®
 Pelletpower® patented self-cleaning burner

Cassetto caricamento pellet in cristallo
 Tiroir de chargement des granulés en cristal
 Pellet loading drawer



OPTIONAL:



iCONTROL
Sistema wi-fi iControl con web-App
 Système wi-fi iControl avec web-App
 Wi-fi system iControl with web-App
 Wi-Fi System iControl mit web-App
 Sistema wi-fi iControl con web-App



ROOM CONTROL
Termostato ambiente wireless con supporto a muro
 Thermostat d'ambiance wireless avec support mural
 Room wireless Thermostat with its wall support
 Kabelloser Raumthermostat mit Wandhalterung
 Termostato de habitación wireless con su soporte de pared



Kit botola Esprit
 Kit de chargement pour Esprit
 Charging kit for Esprit
 Bausatz Einfüllschacht für Esprit
 Kit de carga de pellet para Esprit



Piedistallo regolabile in altezza
 Socle réglable en hauteur
 Height-adjustable pedestal
 Höhenverstellbarer Sockel
 Soporte ajustable en altura

Nero

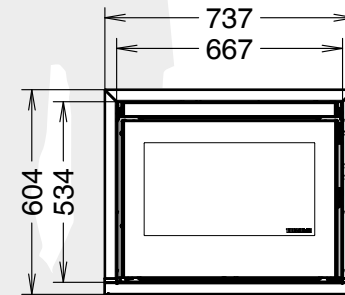
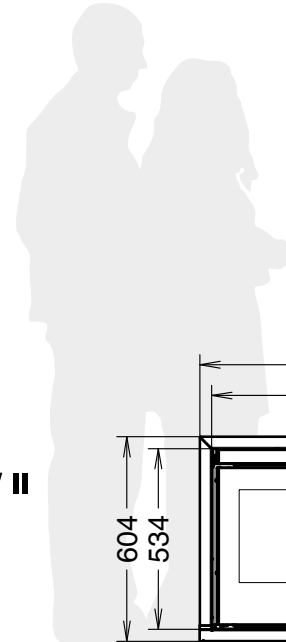

BlmSchV II



Advanced cleaning
PELLETPOWER®
 bruciatore brevettato

Up to
500 hours
 NO-STOP

Eco
 DESIGN
 2022

5
 STELLE
 DM 186/7

7
 ÉTOILES

POLVERI
7
 mg/m³
 13% di O₂



12mx1
 6mx2



90



534x667x459



2,8 - 11



2,6 - 10



0,57 - 2,28



12,5

A+ A++



plus



ESPRIT 600 Evo6

- ITA Inserto a pellet canalizzabile dotato di bruciatore autopulente fino a 500 ore NO-STOP, cassetto caricamento pellet, scambiatore di calore a fascio tubiero Thermocore, fiamma emozionale, wi-fi technology.
- FRA Insert à granulés canalisable, doté de brûleur autonettoyant jusqu'à 500 heures NO-STOP. Tiroir de chargement des granulés, échangeur de chaleur à faisceau tubulaire Thermocore, flamme émotionnelle, prédisposition à la technologie Wi-Fi.
- ENG Ductable pellet insert fitted with a self-cleaning burner with up to 500 hours NO-STOP operation. Pellet loading drawer, Thermocore tube heat exchanger, emotional flame, provision for Wi-Fi technology.
- DEU Kanalisierbarer Pelletheizeinsatz mit selbstreinigendem Brenner für bis zu 500 Stunden NO-STOP. Pelletaufgabekasten, Rohrbündelwärmetauscher Thermocore, angenehmes Flammenbild, Wi-Fi-Anschluss möglich.
- ESP Insertable para chimenea de pellets canalizable, dotado de quemador autolimpiante capaz de funcionar hasta 500 horas NO-STOP. Cajón de carga de pellets, intercambiador de calor tubular Thermocore, llama emocional, predisposición para tecnología wifi.

Una canalizzazione superiore
 Une canalisation supérieure
 One upper ducting outlet



Comando per orientare il flusso d'aria dal frontale alla canalizzazione
 Commande pour orienter le flux d'air de la partie frontale à la canalisation
 Control for directing the air flow from the front to the ducting outlet

Bruciatore autopulente brevettato Pelletpower®
 Brûleur autonettoyant breveté Pelletpower®
 Pelletpower® patented self-cleaning burner

Cassetto caricamento pellet in cristallo
 Tiroir de chargement des granulés en cristal
 Pellet loading drawer



OPTIONAL:



iCONTROL
Sistema wi-fi iControl con web-App
 Système wi-fi iControl avec web-App
 Wi-fi system iControl with web-App
 Wi-Fi System iControl mit web-App
 Sistema wi-fi iControl con web-App



ROOM CONTROL
Termostato ambiente wireless con supporto a muro
 Thermostat d'ambiance wireless avec support mural
 Room wireless Thermostat with its wall support
 Kabelloser Raumthermostat mit Wandhalterung
 Termostato de habitación wireless con su soporte de pared



Kit botola Esprit
 Kit de chargement pour Esprit
 Charging kit for Esprit
 Bausatz Einfüllschacht für Esprit
 Kit de carga de pellet para Esprit



Piedistallo regolabile in altezza.
 Socle réglable en hauteur.
 Height-adjustable pedestal.
 Höhenverstellbarer Sockel.
 Soporte ajustable en altura.

Nero

BlmSchV II

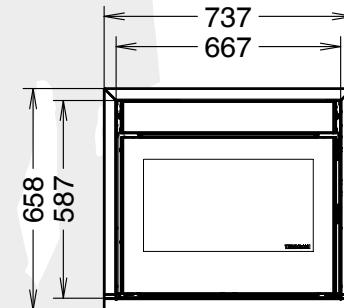

90



587x667x537



2,8 - 11



2,6 - 10



0,57 - 2,28



20,5



Advanced cleaning
PELLETPOWER®
 bruciatore brevettato

Up to
500 hours
 NO-STOP

Eco
 DESIGN
 2022

5
 STELLE
 DM 186/7

7
 ÉTOILES

POLVERI
7
 mg/m³
 13% di O₂



SETUP OK

Easy Cleaning



4 YEARS



XXL

36 decibel



12mx16mx2



EXTERNAL PRIMARY AIR INPUT



Emotional Flame



plus

ESPRIT INFINITY

ITA Inserto a pellet ventilato e canalizzabile con flusso d'aria orientabile, dotato di bruciatore autopulente fino a 500 ore NO-STOP. Cassetto di caricamento pellet in cristallo a scomparsa, vetro serigrafato, camera di combustione in materiale refrattario ceramico, porta focolare in ghisa, scambiatore di calore a fascio tubiero, facilità di pulizia ordinaria e straordinaria, predisposizione wi-fi technology.

FRA Insert à granulés ventilé et canalisable avec flux d'air orientable, doté de brûleur autonettoyant breveté jusqu'à 500 heures NO-STOP. Tiroir de chargement des granulés en cristal rétractable, vitre sérigraphiée, chambre de combustion en céramique réfractaire, porte du foyer en fonte, échangeur de chaleur à faisceau tubulaire, nettoyages ordinaire et extraordinaire faciles, prédisposition à la technologie Wi-Fi.

ENG Pellet insert, ventilated and ductable with air flow that can be directed as desired, fitted with a self-cleaning burner with up to 500 hours NO-STOP operation. Concealed crystal glass pellet loading drawer, silk-screened glass, combustion chamber made of ceramic refractory material, cast iron firebox door, tube heat exchanger, easy routine and extraordinary cleaning, provision for Wi-Fi technology.

DEU Belüfteter und kanalisierbarer Pelletheizeinsatz mit orientierbarem Luftstrom, selbstreinigender Brenner für bis zu 500 Stunden NO-STOP. Einfahrbarer Kristallglaskasten für die Pelletaufgabe, Glas mit Siebdruck, Brennkammer aus feuerfestem Keramikmaterial, Brennraumtür aus Gusseisen, Rohrbündelwärmetauscher, leichte ordentliche und außerordentliche Reinigung, Wi-Fi-Anschluss möglich.

ESP Insertable para chimenea de pellets ventilado y canalizable con flujo de aire orientable, dotado de quemador autolimpiante capaz de funcionar hasta 500 horas NO-STOP. Cajón de carga de pellets retráctil de cristal, vidrio serigrafiado, cámara de combustión de material refractario cerámico, puerta del hogar de hierro fundido, intercambiador de calor tubular, facilidad de limpieza ordinaria y extraordinaria, predisposición para tecnología wifi.

Una canalizzazione superiore
 Une canalisation supérieure
 One upper ducting outlet



Comando per orientare il flusso d'aria dal frontale alla canalizzazione
 Commande pour orienter le flux d'air de la partie frontale à la canalisation
 Control for directing the air flow from the front to the ducting outlet

Bruciatore autopulente brevettato Pelletpower®
 Brûleur autonettoyant breveté Pelletpower®
 Pelletpower® patented self-cleaning burner

Piedistallo regolabile in altezza
 Socle réglable en hauteur
 Height-adjustable pedestal

Cassetto caricamento pellet in cristallo
 Tiroir de chargement des granulés en cristal
 Pellet loading drawer



OPTIONAL:



iCONTROL
Sistema wi-fi iControl con web-App
 Système wi-fi iControl avec web-App
 Wi-Fi system iControl with web-App
 Wi-Fi System iControl mit web-App
 Sistema wi-fi iControl con web-App



ROOM CONTROL
Termostato ambiente wireless con supporto a muro
 Thermostat d'ambiance wireless avec support mural
 Room wireless Thermostat with its wall support
 Kabelloser Raumthermostat mit Wandhalterung
 Termostato de habitación wireless con su soporte de pared



Pietre decorative di colore bianco Carrara o nero ardesia
 Pierres décoratives option couleur blanc mat (Carrare) ou noir mat (ardoise)
 Decorative stone in Carrara white or in slate black colours



Kit botola Esprit
 Kit de chargement pour Esprit
 Charging kit for Esprit
 Bausatz Einfüllschacht für Esprit
 Kit de carga de pellet para Esprit



Piedistallo regolabile in altezza
 Socle réglable en hauteur
 Height-adjustable pedestal
 Höhenverstellbarer Sockel
 Soporte ajustable en altura

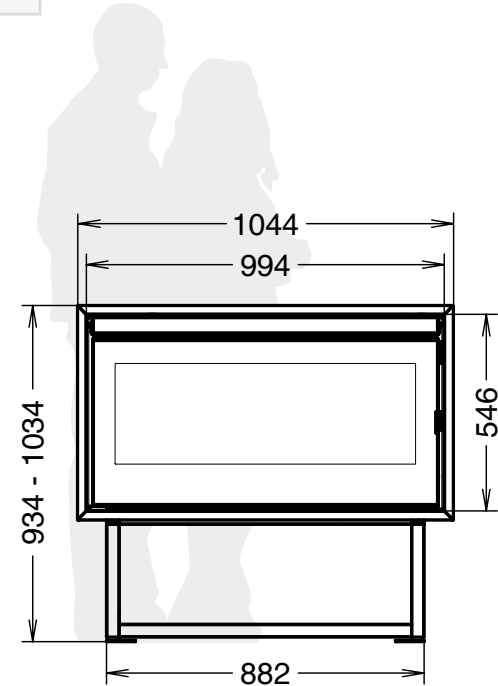

120
 mm
 546x994x550
 kW
 3,8 - 14,3
 kW NOM.
 2,6 - 13,3
 0,8 - 3,0
 30,5



Advanced cleaning
PELLETPOWER®
 bruciatore brevettato

Up to 500 hours NO-STOP

Eco DESIGN 2022

5 STELLE DM 186/7

7 ÉTOILES

BlmSchV II



Nero



plus



PVERTICAL

ITA Caminetto a pellet canalizzabile dal design moderno ed elegante. Grande efficienza e risparmio energetico grazie allo scambiatore a tubi verticale THERMOCORE®, camera di combustione, porta focolare e braciere in ghisa pesante. Pulizia straordinaria e ordinaria semplificata con tecnologia EASY CLEANING, di serie cassetto cenere estraibile. Facile e veloce da installare grazie al kit di collegamento.

FRA Cheminée à granulés canalisable au design moderne et élégant. Grand rendement et économie d'énergie grâce à l'échangeur à tubes vertical THERMOCORE® et à la chambre de combustion, la porte du foyer et le braséro en fonte épaisse. Doté du système de nettoyage ordinaire et extraordinaire simplifié EASY CLEANING, avec tiroir des cendres extractible de série. Simple et rapide d'installation grâce au kit de connexion.

ENG Pvertical is an elegant, modern, with air ducting fireplace. The innovative design of the vertical tube heat exchanger THERMOCORE® allows the appliance to achieve both a very high performance and maximum energy saving. The front door and the pellet burning pot, constructed in heavy cast iron, add an extra degree of reliability and longevity. Equipped with simplified cleaning system EASY CLEANING and with removable ash pan as standard. Easy and quick to install thanks to the support kit.

DEU Kanalisierbarer Pelletheizeinsatz mit einem modernen und eleganten Design mit Schwarzglasfront. Mehr Effizienz und Energieeinsparung dank des THERMOCORE® Wärmetauschers mit vertikalen Röhren. Brennkammer, Tür des Feuerraums und Brenntopf sind aus Gusseisen gefertigt. Dank des EASY CLEANING Systems und der herausnehmbaren Aschenlade ist es möglich mit geringstem Aufwand den Ofen zu reinigen und zu warten. Einfache und schnelle Installation wird durch verschiedene (optionale) Anschluss-Sets gewährleistet.

ESP Insertable de pellet canalizable de diseño moderno y elegante. Gran eficiencia y ahorro energético gracias al intercambiador a tubos verticales THERMOCORE®. Cámara de combustión, puerta y quemador en fundición de alta calidad. Limpiezas ordinarias y extraordinarias simplificadas EASY CLEANING, de serie cajón de cenizas extraíble. Instalación sencilla y rápida gracias a los kits de conexión.

Schermo comandi programmabile
 Programmable control screen
 Panneau des commandes programmable

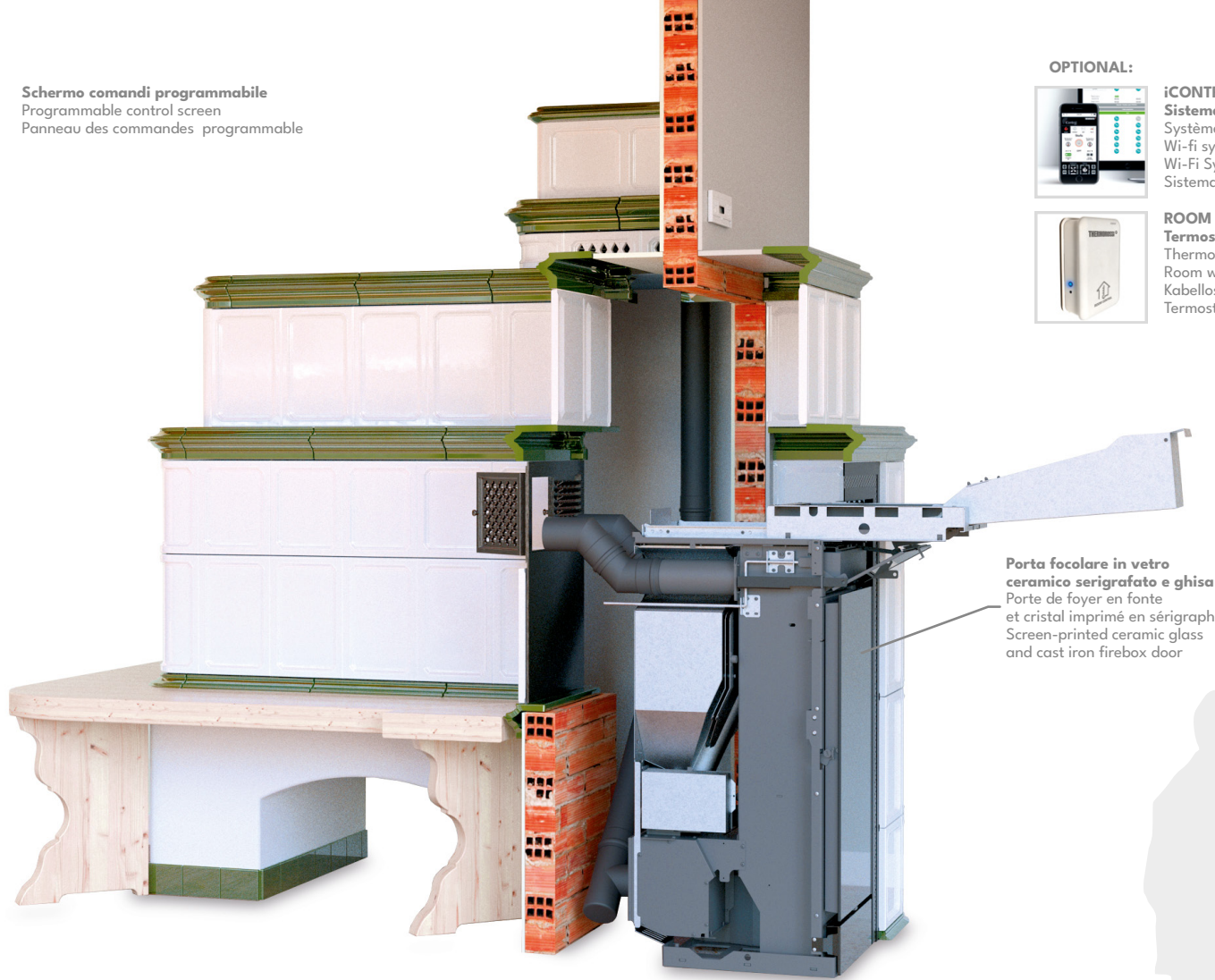

OPTIONAL:



iCONTROL
Sistema wi-fi iControl con web-App
 Système wi-fi iControl avec web-App
 Wi-fi system iControl with web-App
 Wi-Fi System iControl mit web-App
 Sistema wi-fi iControl con web-App



ROOM CONTROL
Termostato ambiente wireless con supporto a muro
 Thermostat d'ambiance wireless avec support mural
 Room wireless Thermostat with its wall support
 Kabelloser Raumthermostat mit Wandhalterung
 Termostato de habitación wireless con su soporte de pared

Porta focolare in vetro
 ceramico serigrafato e ghisa
 Porte de foyer en fonte
 et cristal imprimé en sérigraphie
 Screen-printed ceramic glass
 and cast iron firebox door

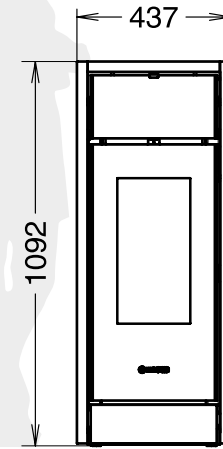
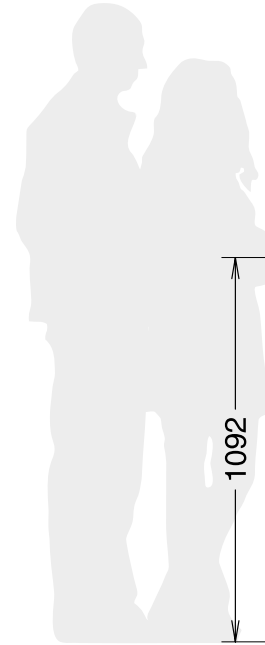

102	
1092x437x557	
3,8 - 12,3	
3,5 - 11,3	kW NOM.
0,8 - 2,6	
17	



BlmSchV II



Nero





idra

INSERT LINE Idrá Evo

- ITA** Caminetto a pellet dal design moderno ed elegante. Grande efficienza e risparmio energetico grazie allo scambiatore a tubi verticale THERMOCORE®, camera di combustione, porta focolare e braciere in ghisa pesante. Dotato di bruciatore motorizzato con tecnologia PELLETPOWER®. Pulizia straordinaria e ordinaria semplificata con tecnologia EASY CLEANING, di serie cassetto cenere estraibile. Facile e veloce da installare grazie al kit di collegamento.
- FRA** Cheminée à granulés au design moderne et élégant. Grand rendement et économie d'énergie grâce à l'échangeur à tubes vertical THERMOCORE® et à la chambre de combustion, la porte du foyer et le braséro en fonte épaisse. Doté du brûleur motorisé avec technologie PELLETPOWER®. Doté du système de nettoyage ordinaire et extraordinaire simplifié EASY CLEANING, avec tiroir des cendres extractible de série. Simple et rapide d'installation grâce au kit de connexion.
- ENG** Insert line 600 Idrá is an elegant and modern pellet powered fireplace. The innovative design of the vertical tube heat exchanger THERMOCORE® allows the appliance to achieve both a very high performance and maximum energy saving. The front door and the pellet burning pot, constructed in heavy cast iron, add an extra degree of reliability and longevity. Equipped with the PELLETPOWER® technology patented burner, with simplified cleaning system EASY CLEANING and with removable ash pan as standard. Easy and quick to install thanks to the support kit.
- DEU** Pelletheizeinsatz mit einem modernen und eleganten Design. Mehr Effizienz und Energieeinsparung dank den Wärmetauscher in vertikalen Röhren THERMOCORE®, Brennkammer, Tür des Feuerraum und Brenntopf in Gusseisen. Ausgestattet mit dem PELLETPOWER® Patentierter Brenner. Ordentliche und außerordentliche Reinigung leichter mit EASY CLEANING System, herausnehmbaren Swerienaschekasten. Einfach und schnell zu installieren, dank dem Anschluss-Set.
- ESP** Insertable de pellet de diseño moderno y elegante. Gran eficiencia y ahorro energético gracias al intercambiador a tubos verticales THERMOCORE®. Cámara de combustión, puerta y quemador en fundición de alta calidad. Equipada con la tecnología de quemador motorizado PELLETPOWER®. Limpiezas ordinarias y extraordinarias simplificadas EASY CLEANING, de serie cajón de cenizas extraíble. Instalación sencilla y rápida gracias a los kits de conexión.

Guide rinforzate di serie per l'estrazione
 Rails renforcés de série pour l'extraction
 Reinforced rails included for extraction

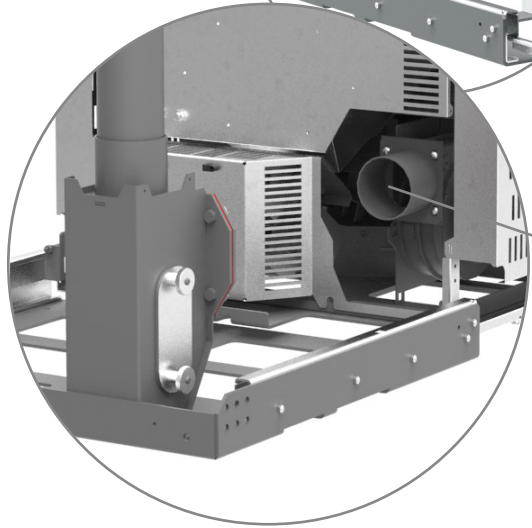
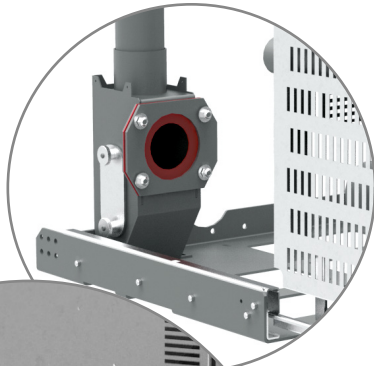

Scarico fumi con innesto a baionetta con dispositivo di sicurezza meccanico ed elettrico per sbloccare l'inserto ed effettuare il carico di pellet
 Sortie des fumées à branchement rapide avec dispositif de sécurité mécanique et électrique pour le déblocage de l'insert et le chargement des granulés
 Smoke outlet with bayonet fitting and mechanical and electrical safety device to unlock the insert and load the pellets

- CRISTALLO - GLASS**
- Bianco
 - Bordeaux
 - Nero
- CERAMICA - CERAMIC**
- Madreperla
 - Ollare
 - Bronze



Optional: Cornice cristallo o ceramica per Insert Line Idrá (disponibile con cristallo bianco, bordeaux, nero, oppure in ceramica bronze, ollare, madreperla)*
 En option : Cadre en cristal ou en céramique pour Insert Line Idrá (disponible en cristal blanc, bordeaux, noir, ou en céramique bronze, pierre ollaire ou nacre)*
 Option: Insert Line Idrá glass or ceramic framework (available in white, bordeaux and black glass or in bronze, soapstone and pearl ceramic)*



Optional: Cornice inox per Insert Line Idrá
 En option : Cadre inox pour Insert Line Idrá
 Option: stainless steel frame for Insert Line Idrá

OPTIONAL:



Kit rapido fisso
 Fast fixed kit
 Kit rapide fixe



Kit Supporto
 Support kit
 Kit de support



INTEGRA TR-PACK
 Thermocell® (250/400/500 lt)
 Thermopuffer (400/500/1500 lt)
 Thermosole® (2.0)

Nero



BImSchV II



128



641x715x655



5,6 - 15,7



5,0 - 14,2



4,4 - 11,8



1,1 - 3,3



20

Dimensioni parte incassata: HxLxP (mm) 594x665x644
 Dimensions partie encaissée : HxLxP (mm) 594x665x644
 Recessed part dimensions: HxWxD (mm) 594x665x644

Optional: Cornici per Insert Line Idrá
 En option : Cadres pour Insert Line Idrá
 Option: Insert Line Idrá frameworks

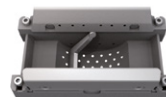
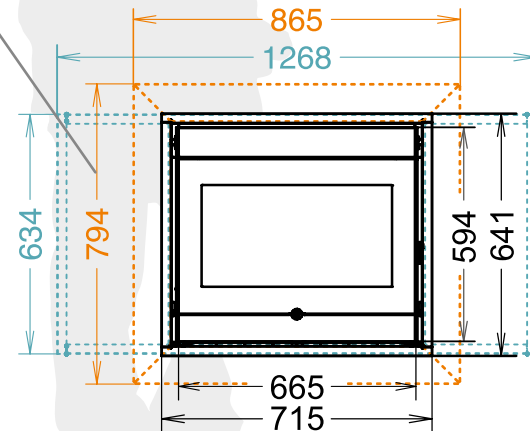

* Fino ad esaurimento scorte
 * Until out of stock

**Obiettivo certificazione - Objectif de certification - Certification goal



A+ A++



idra

INSERT Idra Maxi Evo

- ITA** La gamma dei termocamini a pellet si arricchisce con un nuovo modello ancora più potente. Dal design moderno ed elegante offre una grande efficienza e risparmio energetico grazie allo scambiatore a tubi verticale THERMOCORE®. Porta focolare e braciere in ghisa pesante. Dotato di bruciatore motorizzato con tecnologia PELLETPOWER® garantisce una pulizia straordinaria e ordinaria semplificata, di serie un grande cassetto cenere estraibile. Facilità e rapidità di installazione sono le sue doti esclusive.
- FRA** La gamme des thermo-cheminées à granulés s'enrichit d'un nouveau modèle encore plus puissant. D'un design moderne et élégant, il offre une efficacité et une économie d'énergie élevées grâce à son échangeur tubulaire vertical THERMOCORE®. Porte de foyer et brûleur en fonte épaisse. Doté du brûleur motorisé avec technologie brevetée PELLETPOWER®, il garantit des nettoyages ordinaires et extraordinaires simplifiés. De série un grand tiroir des cendres extractible. Facilité et rapidité d'installation sont des dotes exclusives.
- ENG** The idra pellet-burning inserts collection enhances itself with a new model, even more powerful. From the elegant and the modern design, it offers high thermal efficiency and energy saving, thanks to the vertical pipes heat exchanger THERMOCORE®, heavy cast iron burning grate and firebox door. Equipped with the PELLETPOWER® innovative patented burner, it assures easier cleaning operations, equipped with a removable wide ash pan as standard. An easy and rapid installation is its distinguishing feature.
- DEU** Die wassergeführte Einsatz- Familie erweitert sich mit einem neuen noch leistungsfähigeren Modell. Der Insert Idra Maxi verbindet elegantes und modernes Design mit hoher Effizienz und großer Energieeinsparung dank des vertikalen Rohrwärmetauschers THERMOCORE®. Durch die Ausstattung mit dem innovativen und patentierten PELLETPOWER® Reinigungssystem, der großzügig dimensionierten und herausnehmbaren Aschenlade wird eine einfache Reinigung garantiert. Simple und schnelle Installation ist sein Alleinstellungsmerkmal.
- ESP** La gama de chimeneas de pellets se enriquece con un nuevo modelo más potente. Con su diseño moderno y elegante, ofrece una alta eficiencia y ahorro energético gracias al intercambiador de tuberías verticales THERMOCORE®. Puerta del hogar y quemador en hierro fundido pesado. Equipado con quemador motorizado con tecnología PELLETPOWER®, que garantiza una limpieza y un mantenimiento simplificados. De serie también un cenicero extraíble de gran tamaño. Facilidad y rapidez de instalación son sus características exclusivas.



Botola per il caricamento pellet e pannello comandi a scomparsa
 Trappe pour le chargement des granulés, et panneau des commandes escamotable
 Fuel loading hatch with retractable control panel

Scambiatore di calore con tecnologia Thermocore®
 Échangeur de chaleur Thermocore®
 Thermocore® pipe heat exchanger

Porta focolare in vetro ceramico serigrafato e ghisa
 Porte de foyer en fonte et vitre céramique avec sérigraphie
 Screen-printed ceramic glass and cast iron firebox door

Maniglia removibile. Essenzialità nel design e maggior sicurezza
 Poignée amovible
 Design essentiel et sécurité accrue
 Removable handle
 Essentiality in design and greater safety

Brucciore brevettato Pelletpower®
 Brûleur breveté Pellet Power®
 Patented burner PelletPower®

Monoblocco focolare estraibile con ruote. Facilità nelle operazioni di installazione e manutenzione.
 Foyer monobloc amovible avec roues.
 Installation et entretien faciles
 Removable monobloc firebox with wheels. Easy installation and maintenance.

OPTIONAL:



iCONTROL
Sistema wi-fi iControl con web-App
 Système wi-fi iControl avec web-App
 Wi-fi system iControl with web-App
 Wi-Fi System iControl mit web-App
 Sistema wi-fi iControl con web-App



ROOM CONTROL
Termostato ambiente wireless con supporto a muro
 Thermostat d'ambiance wireless avec support mural
 Room wireless Thermostat with its wall support
 Kabelloser Raumthermostat mit Wandhalterung
 Termostato de habitación wireless con su soporte de pared



Cornice cristallo Insert Line Idra Maxi (disponibile con cristallo bianco, bordeaux o nero)
 Cadre en cristal ou en céramique pour Insert Line Idra Maxi (disponible en cristal blanc, bordeaux, noir)
 Insert Line Idra Maxi glass framework (available in white, bordeaux or black)



Valvola termostatica a 3 vie 1" FFF 55 OT (optional)
 Vanne thermostatique 3 voies 1" FFF 55 OT (optional)
 Thermostatic valve 3 ways 1" FFF 55 OT (optional)

Sonda PT100 (optional-min 2 pz) per funzione «THERMOCONTROL»
 Sonde PT100 (optional-min 2 pces) pour fonction «THERMOCONTROL»
 PT100 sensor (optional-min 2 pc) for «THERMOCONTROL» function



INTEGRA TR-PACK
 Thermocell® (250/400/500 lt)
 Thermopuffer (400/500/1500 lt)
 Thermosole® (2.0)



Optional: Cornice cristallo per Insert Idra Maxi
 En option: Cadre en cristal pour Insert Idra Maxi
 Option: Insert Idra Maxi glass framework

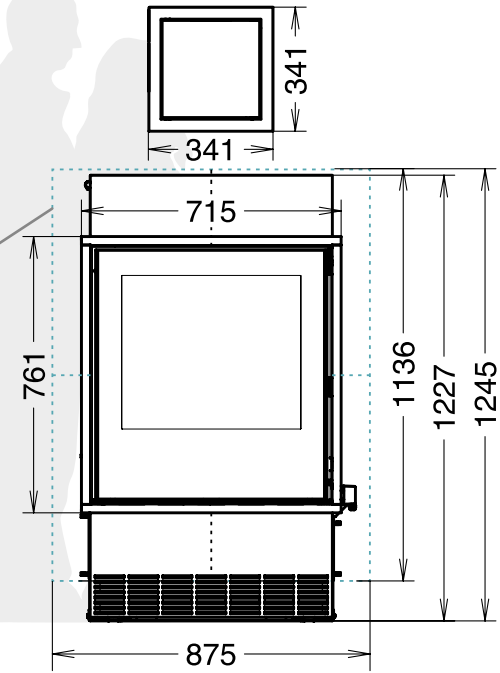

213 mm
 761x715x627
 7,3 - 25,4 kW
 6,7 - 23,7 kW NOM.
 5,9 - 20,4 kW
 0,8 - 3,2
 37

Eco DESIGN 2022
5 STELLE DM 106/7
7 ÉTOILES
POLVERI 7 mg/m³ 13% di O₂
BImSchV II



SETUP OK, Easy Cleaning, 4 YEARS, chrono, XXL, 36 decibel, Pellet Power, mechanical safety devices, EXTERNAL PRIMARY AIR INPUT, Italy

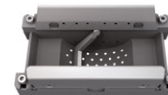

LEGENDA

LEGENDE

LEGEND

ZEICHENERKLÄRUNG

LEYENDA



[mm] Misure (HxLxP)
[mm] Dimensions (HxLxP)
[mm] Dimensions (HxWxD)
[mm] Abmessungen (HxBxT)
[mm] Dimensiones (LxAxP)



[kW] Potenza al focolare (min/max)(a)
[kW] Puissance au foyer (min/max)(a)
[kW] Total Power (min/max)(a)
[kW] Feuerraumleistung (min/max)(a)
[kW] Energia al hogar (min/max)(a)



[kW] Potenza nominale (min/max)(a)
[kW] Puissance nominale (min/max)(a)
[kW] Rated power (min/max)(a)
[kW] Nennleistung (min/max)(a)
[kW] Potencia nominal (min/max)(a)



[kW] Potenza all'acqua (a)
[kW] Puissance à l'eau (a)
[kW] Power to the water (a)
[kW] Leistung ans Wasser (a)
[kW] Energia al agua (a)



[kg] Capacità serbatoio pellet (a)
[kg] Capacité du réservoir à granulés (a)
[kg] Pellet hopper capacity (a)
[kg] Fassungsvermögen Pelletsbehälter (a)
[kg] Cabida tanque de pellets (a)



[kg/h] Consumo orario pellet (min/max)(a)
[kg/h] Consommation horaire pellets (min/max)(a)
[kg/h] Hourly pellet consumption (min/max)(a)
[kg/h] Stündlicher pellet verbrauch (min/max)(a)
[kg/h] Consumo horario pellets (min/max)(a)



[m²] Area riscaldabile (a)(b)
[m²] Chauffez jusqu'à (a)(b)
[m²] Heatable area (a)(b)
[m²] Beheizte Fläche (a)(b)
[m²] Zona calentable (a)(b)

(a) Il dato varia in base al tipo di pellet utilizzato. I valori sono stati rilevati utilizzando pellet omologato secondo normativa EN 14961-2 A1-A2.

(a) La valeur peut changer suivant le type de granulés de bois utilisé. Toutes les données sont enregistrées en utilisant des granulés homologués conformément aux normes EN 14961-2 A1-A2.

(a) Values can change on the basis of the pellet used. These results were obtained using certified pellet according to EN 14961-2 A1-A2.

(a) Die Daten hängen von der Art des verwendeten Pellets ab. Die Werte wurden mit zugelassenen Pellets Gesetzgebung erhoben EN 14961-2 A1-A2.

(a) El dato declarado puede variar segundo el tipo de pellet utilizado. Estos valores se obtuvieron utilizando pellet certificado por la normativa EN 14961-2 A1-A2.

(b) E' importante tenere in considerazione che il volume riscaldabile dipende in modo considerevole dall'isolamento dell'abitazione (classe energetica), dal posizionamento nella planimetria e dalla zona climatica quindi i valori indicati possono variare anche considerevolmente.

(Coefficiente di scambio termico = 37 W/m²)

(b) Il faut considérer que le volume pouvant être réchauffé dépend énormément de l'isolation de l'habitation (classe énergétique), de la disposition des pièces et de la zone climatique. Ces valeurs peuvent donc varier considérablement.

(Coefficient de transfert thermique = 37 W/m²)

(b) It is very important to consider that the potential volume to heat is strictly linked to the insulation of the house (energetic class), to the plan of the building and to the climatic area, so these results may differ more or less according to these aspects. (Heat transfer coefficient = 37 W/m²)

(b) Es ist wichtig zu bedenken, dass die beheizbare Fläche von der Hausisolierung (Energienstufe), von der Positionierung des Ofens im Haus und von der klimatischen Region deutlich abhängt. Die angegebenen Werte können dann auch beträchtlich variieren. (Wärmeübergangskoeffizient = 37 W/m²)

(b) Es muy importante considerar que el volumen calentable depende mucho del aislamiento de la vivienda (clase energética), del plano estructural y de la zona climática, de consecuencia los valores indicados pueden variar en manera considerable. (Coeficiente de película = 37 W/m²)

ATTENZIONE: Gli incentivi per il Conto Termico 2.0 sono da intendersi come esempio a mero titolo indicativo, non contrattuale ed esemplificativo. Il G.S.E. che regola gli incentivi, può riservarsi di aggiornare la regolamentazione degli stessi. Per maggiori informazioni, contatta il punto vendita a te più vicino oppure visita il sito www.gse.it

La ditta costruttrice si riserva di apportare modifiche senza preavviso. Le fabricant se réserve d'apporter des modifications sans préavis. The manufacturer reserves the right to make changes without previous notice.

Der Hersteller behält sich das Recht vor, Änderungen ohne vorherige Ankündigung vorzunehmen.

El productor se reserva el derecho de aportar modificaciones sin preaviso.

CLASSE DE PERFORMANCE



BImSchV II

ENERGY LABEL

L'ETIQUETTE ENERGETIQUE POUR LES PRODUITS A BIOMASSE

ENERGY LABELING FOR BIOMASS PRODUCTS

ENERGIEKENNZEICHNUNG FÜR BIOMASSE PRODUKTE

ETIQUETADO ENERGÉTICO PARA PRODUCTOS DE BIOMASALEYENDA

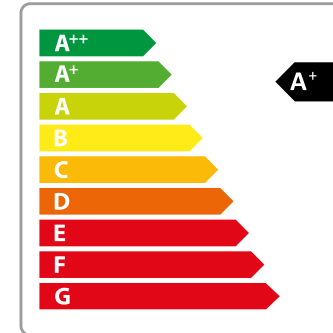

STUFE E THERMOSTUFE
POËLE ET THERMO POËLE
STOVES AND THERMOSTOVES
ÖFEN UND WASSERGEFÜHRTE ÖFEN
THERMOESTUFAS ESTUFAS

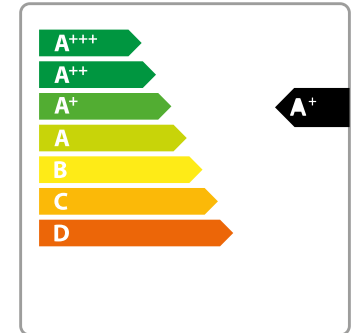

CALDAIE
CHAUDIÈRES
BOILERS
KESSEL
CALDERA

Questa indicazione, basata su direttive e regolamenti dell'Unione Europea, assegna una classe di merito e consente ai clienti scelte informate sulla base dei consumi e dell'efficienza. Cette indication, basée sur les directives et règlements de l'Union européenne, attribue un classement de qualité et permet aux clients de faire un choix éclairé en fonction de la consommation et de l'efficacité.

This indication, based on European Union directives and regulations, assigns a class of merit and allows customers to make informed choices based on the consumption and efficiency of the product.

Diese Angabe, die auf den Richtlinien und Vorschriften der Europäischen Union basiert, weist eine Güteklasse zu und ermöglicht es den Kunden, basierend auf dem Verbrauch und der Effizienz des Produkts fundierte Entscheidungen zu treffen.

Esta indicación, basada en directivas y reglamentos de la Unión Europea, asigna una clase de mérito y permite a los clientes elegir con conocimiento de causa en función del consumo y la eficiencia del producto.

CLASSE DI CERTIFICAZIONE AMBIENTALE

I prodotti Thermorossi qui presentati hanno i requisiti per rientrare nella classe di certificazione a 4 o 5 stelle. Per maggiori informazioni, consulta il sito www.thermorossi.com



ITA - Thermorossi s.p.a. precisa che l'espressione "Up to 500 hours NO-STOP" contenuta nel messaggio promozionale si riferisce a risultati ottenuti in laboratorio, in condizioni di test ottimali. Con la suddetta espressione, quindi, non si descrive una caratteristica tecnica e/o prestazionale del prodotto. Il mancato raggiungimento del risultato in un uso normale, quindi, non deve intendersi come idoneo a configurare una mancanza di qualità della cosa ex art. 1497 c.c., un vizio della medesima ai sensi dell'art. 1490 c.c. od una non conformità dei beni al contratto ai sensi dell'art. 129 del Codice del Consumo. L'utilizzo continuativo fino a 500 ore riguarda esclusivamente i generatori dotati di tecnologia "Pelletpower", ed è subordinato all'impiego di pellet certificato di qualità "A1" ed al mantenimento della potenza di combustione al minimo. L'utilizzo continuativo fino a 500 ore è escluso in ipotesi di interruzione del funzionamento del generatore per qualsiasi causa. Ad ogni interruzione del funzionamento del generatore, prima di effettuare una nuova accensione, l'utilizzatore dovrà necessariamente procedere alle operazioni di pulizia secondo le indicazioni fornite dal manuale in dotazione. L'utilizzatore è tenuto in ogni caso ad attenersi scrupolosamente alle prescrizioni di pulizia e manutenzione previste dal manuale in dotazione, rispettandone esattamente modalità e tempistiche. Eventuali interventi di manutenzione straordinaria dovranno essere eseguiti esclusivamente da un tecnico abilitato in conformità alle disposizioni di legge vigenti. Thermorossi s.p.a. declina ogni responsabilità per eventuali danni a persone o cose determinati da un utilizzo del prodotto non conforme alle predette prescrizioni, o a quelle contenute nel manuale in dotazione.

FRA - Thermorossi S.p.A. précise que l'expression « Up to 500 hours NO-STOP » (Jusqu'à 500 heures NO-STOP) contenue dans le message promotionnel fait référence à des résultats obtenus en laboratoire, dans des conditions de test optimales. Par conséquent, l'expression ci-dessus ne décrit pas une caractéristique technique et/ou de performance du produit. L'impossibilité d'atteindre le résultat dans le cadre d'une utilisation normale ne doit donc pas être interprétée comme constituant un défaut de qualité de la chose au sens de l'art. 1497 du Code Civil italien, un vice de celle-ci au sens de l'art. 1490 du Code Civil italien, ou une non-conformité des biens objet du contrat au sens de l'art. 129 du Code de la Consommation italien. L'utilisation continue jusqu'à 500 heures concerne exclusivement les générateurs équipés de la technologie « Pelletpower », et est soumise à l'utilisation de granulés de qualité certifiée « A1 » et au maintien de la puissance de combustion au minimum. Une utilisation continue jusqu'à 500 heures est exclue en cas d'interruption du fonctionnement du générateur pour quelque raison que ce soit. À chaque interruption de fonctionnement du générateur, avant de le rallumer, l'utilisateur doit procéder aux opérations de nettoyage en suivant les instructions du manuel fourni. Dans tous les cas, l'utilisateur est tenu de suivre scrupuleusement les instructions de nettoyage et d'entretien figurant dans le manuel fourni, en respectant avec précision les méthodes et les délais. Les éventuelles opérations d'entretien extraordinaire doivent être effectuées exclusivement par un technicien autorisé, conformément aux dispositions législatives en vigueur. Thermorossi S.p.A. décline toute responsabilité en cas de dommages aux personnes ou aux choses causés par une utilisation du produit non conforme aux prescriptions susmentionnées, ou à celles contenues dans le manuel fourni.

ENG - Thermorossi S.p.A. underlines that the "Up to 500 hours NO-STOP" expression contained in its promotional message refers to results obtained in the laboratory in optimal test conditions. This expression therefore does not describe a technical and/or performance characteristic of the product. Failing to achieve such a result during normal use, therefore, should not be intended as lack of quality of the good pursuant to art. 1497 of the Italian Civil Code, a defect pursuant to art. 1490 of the Italian Civil Code or a non-conformity of the contract goods pursuant to art. 129 of the Italian Consumer Code. A continuous use of up to 500 hours only concerns generators equipped with the "Pelletpower" technology and is subordinated to using "A1" certified pellets and keeping the combustion power to the minimum level. A continuous use of up to 500 hours is excluded in case of an interruption of the generator operation for whatever cause. Every time the generator operation is interrupted, the user must necessarily proceed with the cleaning operations indicated in the manual provided before lighting it up again. Users must in any case scrupulously follow the cleaning and maintenance instructions contained in the manual provided, strictly complying with procedures and time-frames. Any extraordinary maintenance interventions must be carried out exclusively by an authorised technician in compliance with current regulations. Thermorossi S.p.A. declines all responsibility for any damage to things or people caused by usage not compliant with the provisions above or with those in the manual provided.

DEU - Die Thermorossi S.p.A. weist darauf hin, dass sich der in der Werbebotschaft enthaltene Ausdruck "Up to 500 hours NO-STOP" auf Resultate bezieht, die unter optimalen Testbedingungen im Labor erzielt wurden. Mit dem obigen Ausdruck wird also keine technische Eigenschaft oder ein Leistungsmerkmal des Produktes beschrieben. Wenn das Resultat im normalen Gebrauch nicht erreicht wird, darf dies nicht mit dem Fehlen einer zugesicherten Eigenschaft des Gutes nach Art. 1497 Codice Civile (ital. BGB), einem Produktmangel im Sinne von Art. 1490 Codice Civile oder einer Vertragswidrigkeit im Sinne von Art. 129 des Codice del Consumo (ital. Verbrauchergesetz) gleichgesetzt werden. Die Dauernutzung von bis zu 500 Stunden betrifft ausschließlich die Wärmeerzeuger, die mit der Technologie "Pelletpower" ausgestattet sind. Voraussetzung ist, dass zertifizierte Pellets der Qualität "A1" verwendet und die Verbrennungsleistung auf der Mindeststufe gehalten wird. Ein Dauerbetrieb von bis zu 500 Stunden ist ausgeschlossen für den Fall, dass der Betrieb des Wärmeerzeugers aus irgendeinem Grunde unterbrochen wird. Bei jeder Betriebsunterbrechung des Wärmeerzeugers muss der Betreiber, bevor ein neuer Zündvorgang eingeleitet wird, die Reinigungsschritte ausführen, die im beiliegenden Handbuch angegeben sind. Der Betreiber ist in jedem Fall verpflichtet, sich in Bezug auf die Art und die Zeiten genau an die Reinigungs- und Wartungsvorschriften des beiliegenden Handbuchs zu halten. Etwaige außerordentliche Wartungen dürfen ausschließlich von einem Techniker vorgenommen werden und müssen in Übereinstimmung mit den geltenden Gesetzen erfolgen. Thermorossi S.p.A. lehnt jede Haftung für etwaige Personen- oder Sachschäden ab, die auf eine Nutzung zurückgehen, die nicht den vorgenannten Vorschriften oder dem Inhalt des Handbuchs entspricht.

ESP - Thermorossi S.p.A. precisa que la expresión "Up to 500 hours NO-STOP" (Hasta 500 horas NO-STOP) contenida en el mensaje promocional se refiere a resultados obtenidos en laboratorio, en condiciones de prueba ideales. Con dicha expresión no se describe una característica técnica y/o de rendimiento del producto. Por lo tanto, el incumplimiento del resultado con un uso normal no debe considerarse una falta de calidad del producto conforme al art. 1497 del Código Civil italiano, un defecto del mismo conforme al art. 1490 del Código Civil italiano o una no conformidad de los bienes objetos del contrato conforme al art. 129 del Código del Consumidor italiano. El uso continuo hasta 500 horas se refiere exclusivamente a los generadores dotados de tecnología "Pelletpower", y está subordinado al uso de pellet certificado de calidad "A1" y al mantenimiento de la potencia de combustión al mínimo. El uso continuo hasta 500 horas queda excluido en caso de interrupción del funcionamiento del generador por cualquier causa. Cada vez que se interrumpe el funcionamiento del generador, antes de realizar un nuevo encendido, el usuario debe proceder obligatoriamente a las operaciones de limpieza según las indicaciones contenidas en el manual suministrado. En cualquier caso, el usuario está obligado a atenerse estrictamente a las prescripciones de limpieza y mantenimiento previstas en el manual suministrado, respetando exactamente las formas y tiempos indicados. Las eventuales intervenciones de mantenimiento extraordinario deben ser realizadas exclusivamente por un técnico habilitado conforme a las disposiciones legales vigentes. Thermorossi S.p.A. declina toda responsabilidad por eventuales daños a personas u objetos determinados por un uso del producto no conforme a las prescripciones anteriores o a las indicaciones contenidas en el manual suministrado.

Prima dell'acquisto, richiedete al Vostro rivenditore tutte le informazioni relative all'installazione dell'apparecchio (vedi manuale d'uso)
Avant l'achat, demander à votre revendeur toutes les informations nécessaires pour l'installation de l'appareil (voir manuel pour l'utilisation)
Before purchasing the appliance ask your reseller for all the relevant information concerning its installation (see user's guide)
Vor dem Kauf erfragen Sie bitte bei Ihrem Händler alle Informationen zur Installation des Gerätes (siehe Betriebsanleitung)
Antes de adquirir el aparato, soliciten al vendedor todas las informaciones para su instalación (véase el manual de uso)

Uomo/Man 1800 mm
Donna/Woman 1650 mm
Scala/scale 1:20

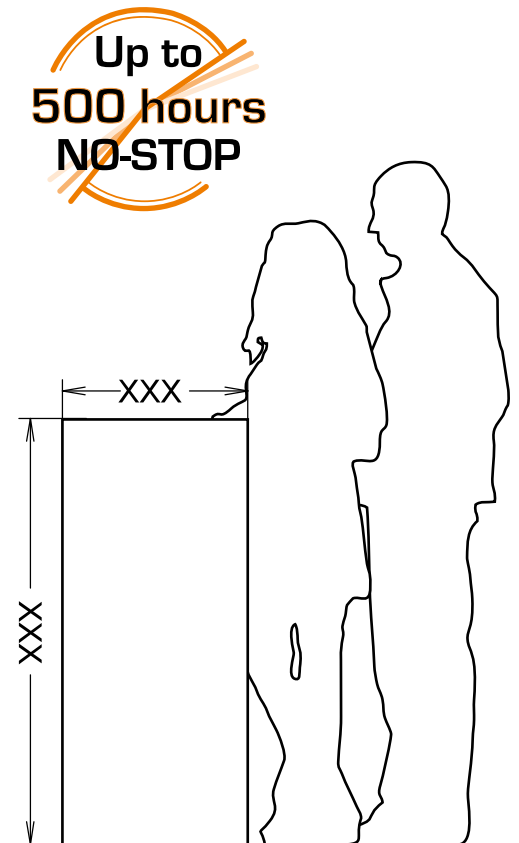

Traduzione termini tecnici
Technical terms translation

Mandata - Mandata impianto
System delivery

Ritorno - Ritorno impianto
System return

Uscita fumi
Smoke outlet

Uscita canalizzazione aria calda
Hot air ducting outlet

Valvola di sicurezza
Safety valve

Valvola scarico termico
Blow down valve

Ritorno e scarico impianto
Return and system discharge

THERMOROSSI

Fire Lovers

- Pellet Home Collection -

THERMOROSSI

Fire Lovers

Seguici su:
Find us on:



THERMOROSSI S.p.A.
Via Grumolo, 4 (Z.I.)
36011 Arsiero (VI) - ITALY
www.thermorossi.com
info@thermorossi.it

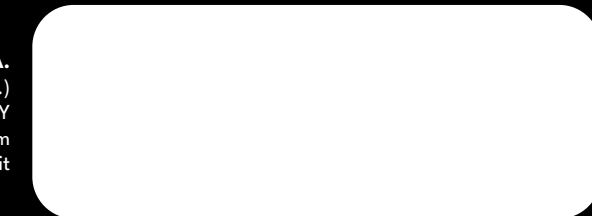

Worldwide - Phone: 0039.0445.741310 - e-mail: export@thermorossi.it